

Disclaimer

The following version of the Owner's Manual describes all models, series and special equipment of your vehicle. Country-specific language variations are possible. Please note that your vehicle might not be equipped with all the described functions. This also affects safety-relevant systems and functions. Please contact your authorised Mercedes-Benz dealership if you would like to receive a printed Owner's Manual for other vehicle models and vehicle model years.

The online Owner's Manual is the current and valid version. It is possible that deviations affecting your specific vehicle could not be taken into account as Mercedes-Benz constantly adapts its vehicles according to the latest technology and makes changes to the form and the equipment.

Please also read the printed Owner's Manual, supplementary documents and the digital Owner's Manual in the vehicle.

Copyright

All rights reserved. All texts, images and graphics are subject to copyright and other laws for the protection of intellectual property. They may not be copied or changed for any commercial use or for the purpose of being passed on nor used on other websites.





E-Class Saloon

Owner's Manual

Mercedes-Benz





Symbols

In this Owner's Manual, you will find the following symbols:

 **DANGER** Danger due to not observing the warning notices

Warning notices draw your attention to hazards that may endanger your health or life, or the health or life of others.

 Please observe the warning notices in this Owner's Manual.

 **ENVIRONMENTAL NOTE** Environmental damage due to failure to observe environmental notes

Environmental notes include information on environmentally responsible behaviour or environmentally responsible disposal.

 Observe environmental notes.

 **NOTE** Damage to property due to failure to observe notes on material damage

Notes on material damage inform you of risks which may lead to your vehicle being damaged.

 Observe notes on material damage.

 Useful instructions or further information that could be helpful to you.

 Instruction

(→ page) Further information on a topic

Display Information in the multifunction display/multimedia display



Highest menu level, which is to be selected in the multimedia system



Corresponding submenus, which are to be selected in the multimedia system

*

Indicates a cause

Welcome to the world of Mercedes-Benz

Before you first drive off, read this Owner's Manual carefully and familiarise yourself with your vehicle. For your own safety and a longer vehicle life, follow the instructions and warning notices in this manual. Disregarding them may lead to damage to the vehicle or personal injury.

The equipment or model designation of your vehicle may vary according to:

- model
- order
- national version
- availability

The illustrations in this manual show a left-hand drive vehicle. On right-hand drive vehicles, the layout of components and controls differs accordingly.

Mercedes-Benz is constantly updating its vehicles to the state of the art.

Mercedes-Benz therefore reserves the right to introduce changes in the following areas:

- design

- equipment
- technical features

The equipment in your vehicle may therefore differ from that shown in the descriptions and illustrations.

The following are integral parts of the vehicle:

- Digital Owner's Manual
- Printed Owner's Manual
- Service Booklet
- Equipment-dependent Supplements

Keep these documents in the vehicle at all times. If you sell the vehicle, always pass all of the documents on to the new owner.

2135846507Z102



At a glance	6	Copyright	30	Using the memory function	106
Cockpit	6			Stowage areas	107
Overview of warning and indicator lamps	10	Occupant safety	31	Cup holders	118
Overhead control panel	14	Restraint system	31	Ashtray and cigarette lighter	120
Door control panel and seat adjustment	16	Seat belts	33	Sockets	121
Emergencies and breakdowns	18	Airbags	38	Wireless charging of the mobile phone and connection with the exterior aerial	124
		PRE-SAFE® system	45	Fitting or removing the floor mats	126
		Children in the vehicle	46		
		Notes on pets in the vehicle	65		
Digital Owner's Manual	20			Light and sight	127
Calling up the Digital Owner's Manual	20	Opening and closing	67	Exterior lighting	127
		Key	67	Interior lighting	136
		Doors	71	Changing bulbs (only for vehicles with halogen headlamps)	137
General notes	21	Boot	76	Windscreen wipers and windscreen washer system	140
Protection of the environment	21	Roller sunblinds	81	Mirrors	142
Take-back of end-of-life vehicles	21	Side windows	83	Operating the sun visors	145
Mercedes-Benz GenuineParts	22	Sliding sunroof	86	Infrared reflective windscreen	146
Owner's Manual	23	Anti-theft protection	91		
Operating safety	23			Climate control	147
Declaration of Conformity	24	Seats and stowing	94	Overview of climate control systems	147
Diagnostics connection	26	Notes on the correct driver's seat position ...	94	Operating the climate control system	148
Qualified specialist workshop	26	Seats	95		
Vehicle registration	27	Steering wheel	103		
Correct use of the vehicle	27				
Implied warranty	27				
QR code for rescue card	27				
Vehicle data storage	28				

Driving and parking	159
Driving	159
DYNAMIC SELECT switch	170
Manual transmission	170
Automatic transmission	172
Refuelling	176
Parking	181
Driving and driving safety systems	190
Trailer hitch	244
Bicycle rack	248

Instrument Display and on-board computer	251
Instrument display overview	251
Overview of the buttons on the steering wheel	252
Operating the on-board computer	253
Setting the additional value range	254
Overview of displays on the multifunction display	255
Adjusting the instrument lighting	255
Menus and submenus	256
Head-up Display	262

Multimedia system	264
Overview and operation	264
System settings	273
Garmin® MAP PILOT navigation module	276
Telephone	277
Online and Internet functions	293
Media	295
Radio	301
Sound	304

Maintenance and care	306
ASSYST PLUS service interval display	306
Engine compartment	307
Cleaning and care	314

Breakdown assistance	322
Emergency	322
Flat tyre	324
Battery (vehicle)	330
Tow-starting or towing away	335
Electrical fuses	341

Wheels and tyres	344
Notes on noise or unusual handling characteristics	344
Regular checking of wheels and tyres	344
Notes on snow chains	345
Tyre pressure	345
Wheel change	352
Emergency spare wheel	362

Technical data	364
Notes on technical data	364
On-board electronics	364
Vehicle identification plate, VIN and engine number	366
Operating fluids	368
Vehicle data	376
Trailer hitch	378

Display messages and warning/indicator lamps	381
Display messages	381
Warning and indicator lamps	438

Index	456
--------------------	------------

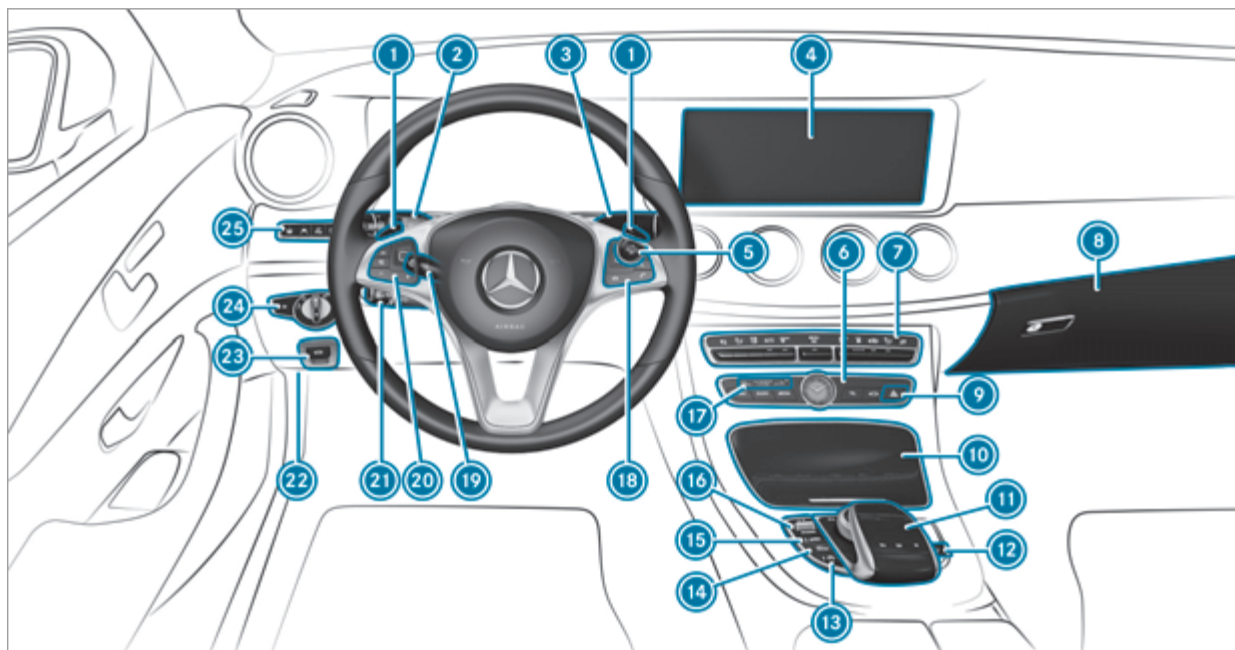

Left-hand drive vehicle

①	Steering wheel gearshift paddle	→	174	⑩	Stowage compartment	→	108
②	Combination switch	→	129	⑪	Control elements for the multimedia system	→	264
③	DIRECT SELECT lever	→	172	⑫	Rear window roller sunblind	→	82
④	Display (multimedia system)	→	264	⑬	ECO start/stop function	→	167
⑤	Start/stop button	→	160	⑭	Active Parking Assist	→	228
⑥	Control panel for the multimedia system	→	264	⑮	Sets the vehicle level	→	215
⑦	Climate control systems	→	147	⑯	DYNAMIC SELECT switch	→	170
⑧	Glove box	→	109	⑰	PASSENGER AIRBAG indicator lamps	→	42,
⑨	Hazard warning lamps	→	130	⑱	Control panel for the multimedia system	→	252
				⑲	Adjusts the steering wheel	→	104
				⑳	Control panel for the on-board computer	→	252
				㉑	Cruise control lever	→	203
				㉒	Unlocks the bonnet	→	308
				㉓	Electric parking brake	→	186
				㉔	Light switch	→	127
				㉕	Control panel for:		
					Active Steering Assist	→	211
					Active Lane Keeping Assist	→	243
					Parking Assist PARKTRONIC	→	218
					Head-up display	→	263

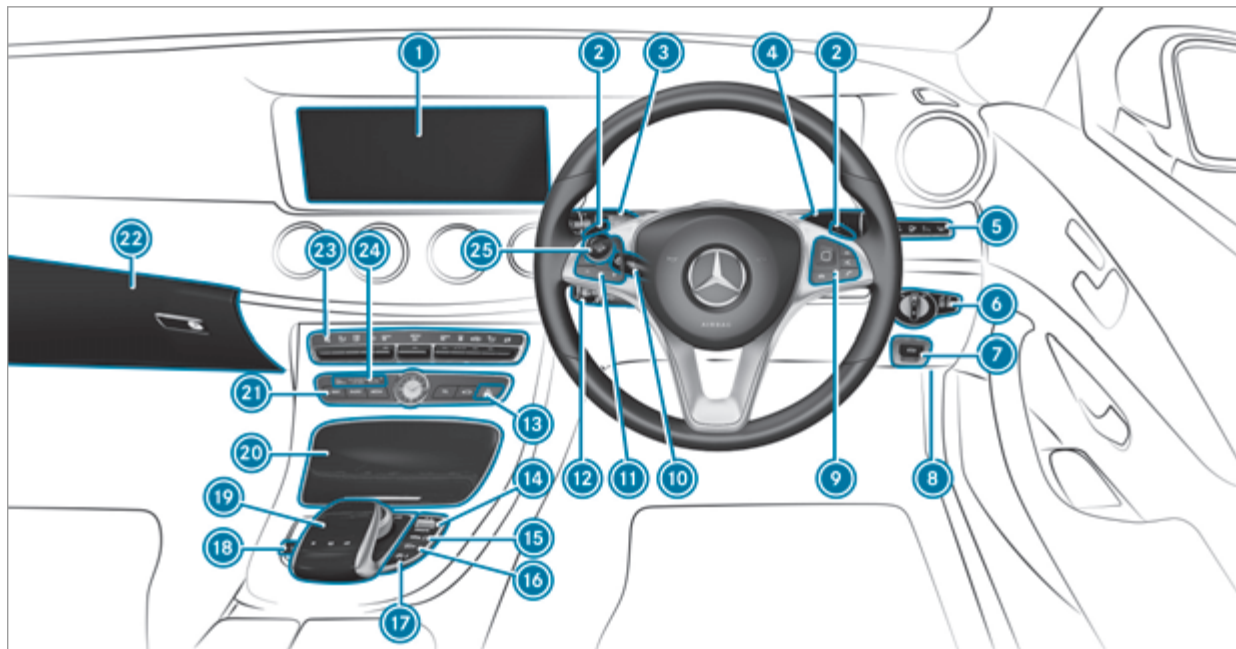





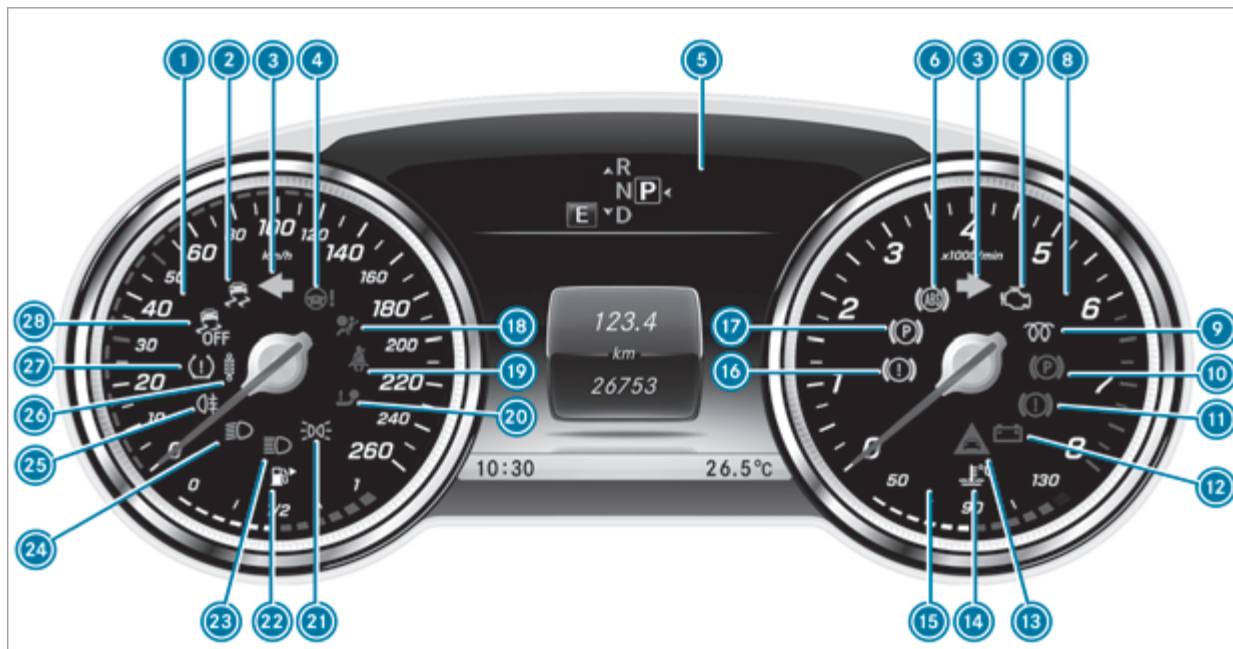



































Right-hand drive vehicle

①	Display (multimedia system)	→	264	⑫	Cruise control lever	→	203
②	Steering wheel gearshift paddle	→	174	⑬	Hazard warning lamps	→	130
③	Combination switch	→	129	⑭	DYNAMIC SELECT switch	→	170
④	DIRECT SELECT lever	→	172	⑮	Sets the vehicle level	→	215
⑤	Control panel for:			⑯	Active Parking Assist	→	228
	Active Steering Assist	→	211	⑰	ECO start/stop function	→	167
	Active Lane Keeping Assist	→	243	⑱	Rear window roller sunblind	→	82
	Parking Assist PARKTRONIC	→	218	⑲	Control elements for the multimedia system	→	264
	Head-up display	→	263	⑳	Stowage compartment	→	108
⑥	Light switch	→	127	㉑	Control panel for the multimedia system	→	264
⑦	Electric parking brake	→	186	㉒	Glove box	→	109
⑧	Unlocks the bonnet	→	308	㉓	Climate control systems	→	147
⑨	Control panel for the multimedia system	→	252	㉔	PASSENGER AIRBAG indicator lamps	→	42,
⑩	Adjusts the steering wheel	→	104	㉕	Start/stop button	→	160
⑪	Control panel for the on-board computer	→	252				







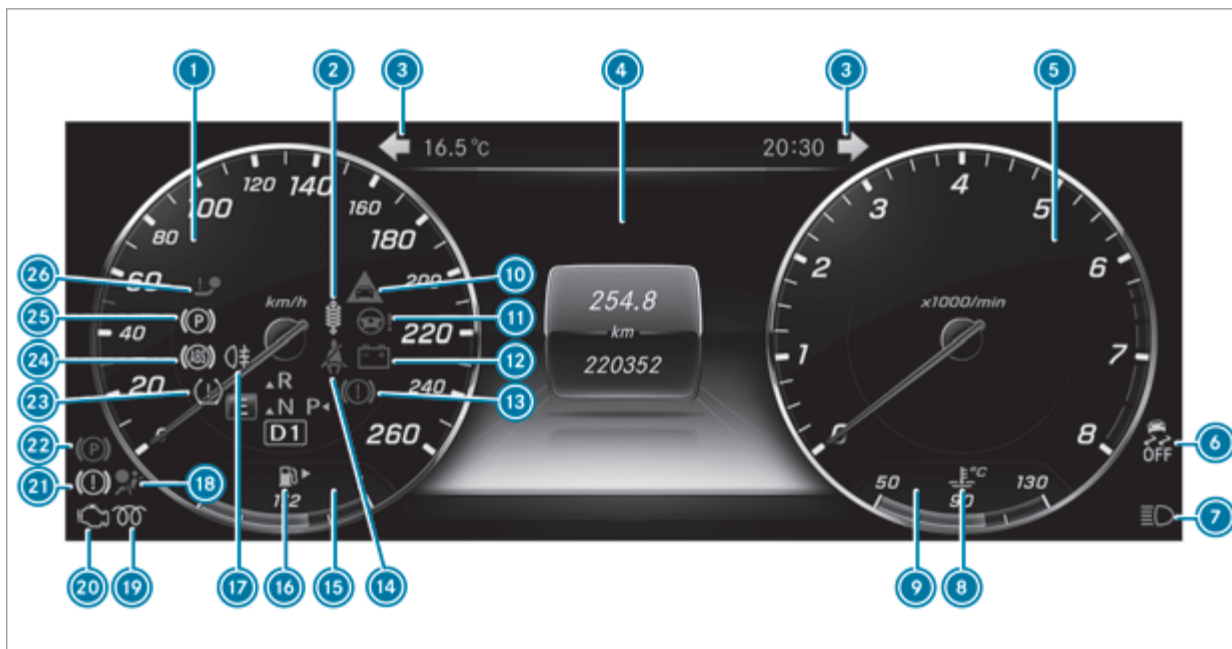



















Instrument display (standard)







①	 Speedometer	→	251	⑪	 Brakes (red)	→	440
②	 ESP®	→	440	⑫	 Electrical fault	→	451
③	 Turn signal light	→	129	⑬	 Distance warning	→	447
④	 Steering assistance malfunction	→	449	⑭	 Coolant too hot/cold	→	451
⑤	Multifunction display	→	255	⑮	Coolant temperature display	→	251
⑥	 ABS malfunction	→	440	⑯	 Brakes (yellow)	→	440
⑦	 Engine diagnosis	→	451	⑰	 Electric parking brake (yellow)	→	440
⑧	Rev counter	→	251	⑱	 Restraint system	→	32
⑨	 Diesel engine: preglow			⑲	 Seat belt is not fastened	→	446
⑩	 Electric parking brake applied (red)	→	440	⑳	 Trailer hitch is not operational or is swiveling	→	449
⑪	 Brakes (red)	→	440	㉑	 Standing lights	→	127
⑫	 Electrical fault	→	451	㉒	Fuel level display		
⑬	 Distance warning	→	447	 Fuel reserve with fuel filler flap location indicator	→	451	
⑭	 Coolant too hot/cold	→	451	㉓	 Main beam	→	129
⑮	Coolant temperature display	→	251	㉔	 Dipped beam	→	127
⑯	 Brakes (yellow)	→	440	㉕	 Rear fog light	→	128
⑰	 Electric parking brake (yellow)	→	440	㉖	AIR BODY CONTROL/DYNAMIC BODY CONTROL malfunctioning	→	447
⑱	 Restraint system	→	32	㉗	 Tyre pressure monitoring system	→	454
⑲	 Seat belt is not fastened	→	446	㉘	 ESP® OFF	→	440
⑳	 Trailer hitch is not operational or is swiveling	→	449				
㉑	 Standing lights	→	127				
㉒	Fuel level display						
㉓	 Fuel reserve with fuel filler flap location indicator	→	451				
㉔	 Main beam	→	129				
㉕	 Dipped beam	→	127				
㉖	 Rear fog light	→	128				
㉗	AIR BODY CONTROL/DYNAMIC BODY CONTROL malfunctioning	→	447				
㉘	 Tyre pressure monitoring system	→	454				
㉙	 ESP® OFF	→	440				

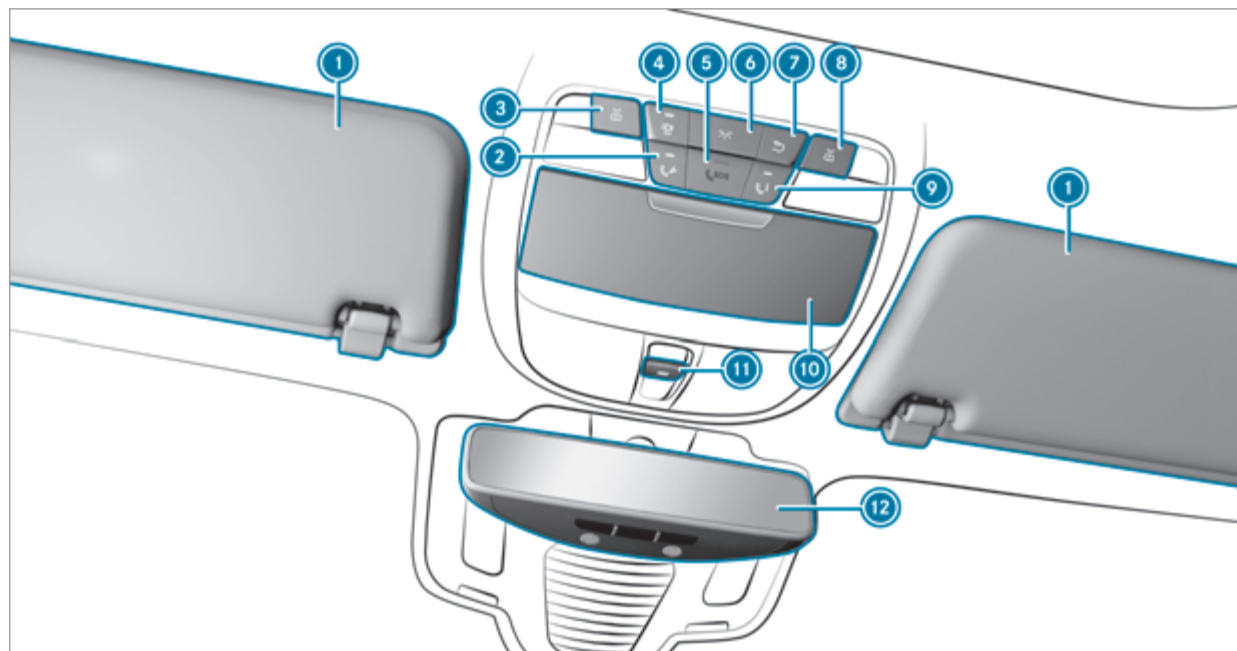





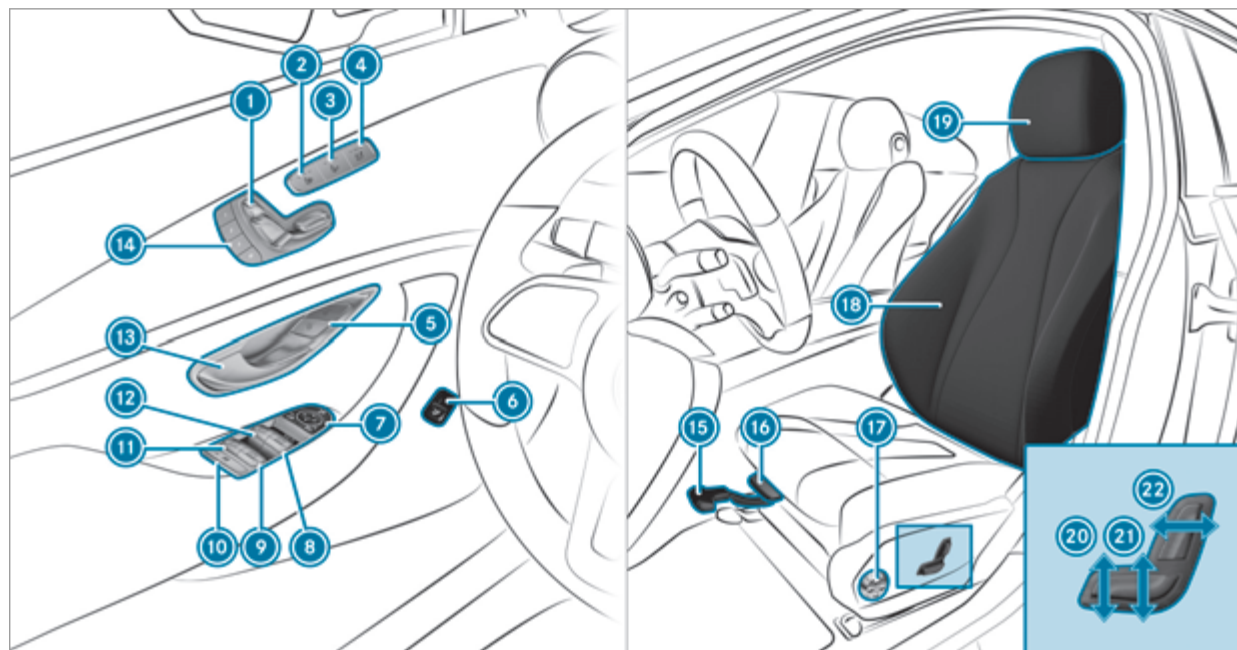

Instrument display in the widescreen cockpit

①	Speedometer	→	251	⑬	 Brakes (red)	→	440
②	AIR BODY CONTROL/DYNAMIC BODY CONTROL malfunctioning	→	447	⑭	 Seat belt is not fastened	→	446
③	  Turn signal light	→	129	⑮	Fuel level display		
④	Multifunction display	→	255	⑯	 Fuel reserve with fuel filler flap location indicator	→	451
⑤	Rev counter	→	251	⑰	 Rear fog light	→	128
⑥	 ESP® OFF	→	440	⑱	 Restraint system	→	32
	 ESP®	→	440	⑲	 Diesel engine: preglow		
⑦	 Main beam	→	129	⑳	 Engine diagnosis	→	451
	 Dipped beam	→	127	㉑	 Brakes (yellow)	→	440
	 Standing lights	→	127	㉒	 Electric parking brake applied (red)	→	440
⑧	 Coolant too hot/cold	→	451	㉓	 Tyre pressure monitoring system	→	454
⑨	Coolant temperature display	→	251	㉔	 ABS malfunction	→	440
⑩	 Distance warning	→	447	㉕	 Electric parking brake (yellow)	→	440
⑪	 Steering assistance malfunction	→	449	㉖	 Trailer hitch is not operational or is swiveling	→	449
⑫	 Electrical fault	→	451				



①	Sun visors	→	145	⑦	 Switches the rear interior lighting on/off	→	136
②	Breakdown assistance call button (Mercedes me connect)	→	289	⑧	 Switches the right-hand reading lamp on/off	→	136
③	 Switches the left-hand reading lamp on/off	→	136	⑨	MB Info call button (Mercedes me connect)	→	288
④	 Switches the automatic lighting control on/off	→	136	⑩	Spectacles compartment	→	109
⑤	SOS emergency call system (Mercedes-Benz emergency call system)	→	290	⑪	 Opens/closes the panoramic sliding sunroof	→	86
⑥	 Switches the front interior lighting on/off	→	136		Opens/closes the roller sunblinds	→	86
				⑫	Inside rearview mirror	→	143



①	Adjusts the seats electrically	→	98	⑫	 Opens/closes the left side window	→	83
②	Switches the seat heater on/off	→	101	⑬	Opens the door	→	71
③	Switches the seat ventilation on/off	→	103	⑭	Sets the memory function	→	106
④	Adjusts the front passenger seat from the driver's seat	→	98	⑮	Sets the seat fore-and-aft adjustment	→	97
⑤	  Locks/unlocks the vehicle	→	72	⑯	Adjusts the seat cushion length	→	97
⑥	Opens/closes the boot lid	→	76	⑰	Adjusts the 4-way lumbar support	→	99
⑦	Adjusts and folds the outside mirrors out/in electrically	→	142	⑱	Seat adjustment using the multimedia system		
⑧	 Opens/closes the right side window	→	83	⑲	Adjusts the head restraints	→	99
⑨	 Opens/closes the rear right side window	→	83	⑳	Adjusts the seat cushion inclination	→	97
⑩	Child safety lock for the rear side windows	→	65	㉑	Adjusting the seat height	→	97
⑪	 Opens/closes the rear left side window	→	83	㉒	Sets the seat backrest inclination	→	97

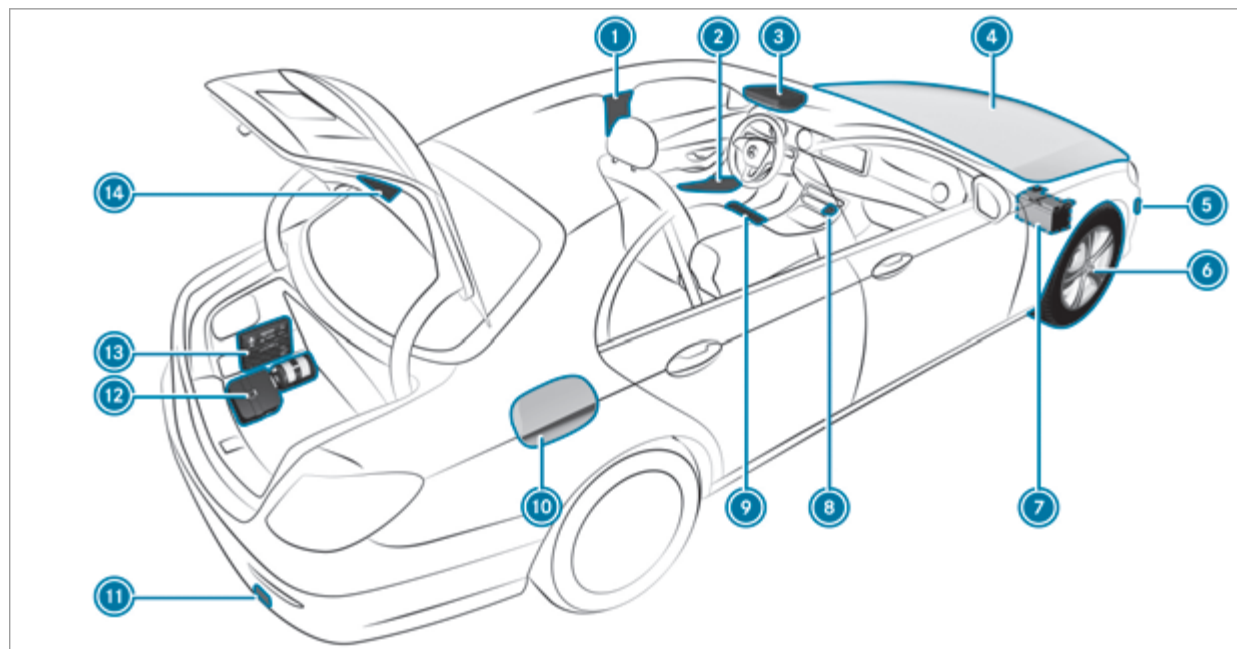

What to do in the event of an accident		
① QR code for accessing the rescue card	→	27
② Safety vests	→	322
③ Button for the SOS emergency call system and breakdown assistance	→	290
④ Checking and topping up service products	→	368
⑤ Tow-starting and towing away	→	336
⑥ Flat tyre	→	324
⑦ Jump-starting	→	332
⑧ Hazard warning lamps	→	130
⑨ Fire extinguisher	→	324
⑩ Fuel filler flap with instruction labels for tyre pressure, fuel type and QR code for accessing the rescue card	→	176
⑪ Tow-starting and towing away	→	336
⑫ TIREFIT kit	→	326
⑬ First-aid kit (soft sided)	→	323
⑭ Warning triangle	→	323

Calling up the Digital Owner's Manual

Multimedia system:

↳ Vehicle ▶ Owner's Manual

▶ Select a menu item.

The Digital Owner's Manual describes the function and operation of:



- the vehicle
- the multimedia system

For safety reasons, the Digital Owner's Manual is deactivated while driving.

The Digital Owner's Manual contains the following menu items:

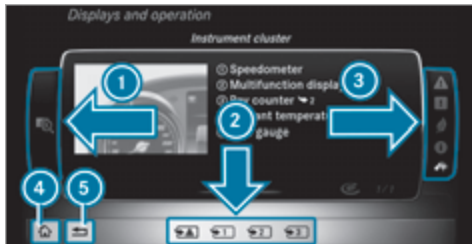
- **Search:** allows you to search precisely for keywords.
- **Quick start:** provides you with important information so that you can start using your vehicle immediately.
- **Tips:** provides tips on how to use your vehicle in certain situations.
- **Bookmarks:** provides you with a list of all the bookmarks you have stored yourself.



- ▶ **To scroll forwards/backwards:** turn the controller.
- ▶ **To display in full screen:** navigate to the left ①.
- ▶ **To select a note or store a bookmark:** navigate to the right ③.
- ▶ **To select a link:** navigate down ②.
- ▶ **To exit a content page:** select the  symbol ⑤.
- ▶ **To call up the basic menu of the Digital Owner's Manual:** select the  symbol ④.

▶ **To switch functions to the multimedia system using the buttons on the centre console:** press the **NAVI**, **RADIO**, **MEDIA** or **TEL** button.

The selected menu appears. The Digital Owner's Manual remains open in the background.

- ① The Owner's Manual can also be found in the Mercedes-Benz Guides App in all common App Stores.

Protection of the environment

 **ENVIRONMENTAL NOTE** Environmental damage due to operating conditions and personal driving style

The pollutant emission of your vehicle is directly related to the way you operate your vehicle.

You can help to protect the environment by operating your vehicle in an environmentally-responsible manner. Please observe the following recommendations on operating conditions and personal driving style.

Operating conditions:

- ▶ Make sure that the tyre pressure is correct.
- ▶ Do not carry any unnecessary weight (e.g. roof luggage racks once you no longer need them).
- ▶ Adhere to the service intervals. A regularly serviced vehicle will contribute to environmental protection.

- ▶ Always have service work carried out at a qualified specialist workshop.

Personal driving style:

- ▶ Do not depress the accelerator pedal when starting the engine.
- ▶ Do not warm up the engine while the vehicle is stationary.
- ▶ Drive carefully and maintain a suitable distance from the vehicle in front.
- ▶ Avoid frequent, sudden acceleration and braking.
- ▶ Change gear in good time and use each gear only up to $\frac{2}{3}$ of its maximum engine speed.
- ▶ Switch off the engine in stationary traffic, e.g. by using the ECO start/stop function.
- ▶ Drive in a fuel-efficient manner.

Take-back of end-of-life vehicles

EU countries only:

Mercedes-Benz will take back your end-of-life vehicle for environment-friendly disposal in accordance with the European Union (EU) End-of-Life Vehicles Directive.

A network of vehicle take-back points and dismantlers has been established for you to return your vehicle. You can leave it at any of these points free of charge. This makes an important contribution to closing the recycling circle and conserving resources.

For further information about the recycling and disposal of end-of-life vehicles, and the take-back conditions, please visit the national Mercedes-Benz website for your country.

Mercedes-Benz GenuineParts



ENVIRONMENTAL NOTE Environmental damage caused by not using recycled reconditioned components

Daimler AG offers recycled reconditioned components and parts with the same quality as new parts. The same entitlement from the implied warranty is valid as for new parts.

- ▶ Use recycled reconditioned components and parts from Daimler AG.



NOTE Impairment of the operating efficiency of the restraint systems from installing accessories or from repairs or welding

Airbags and seat belt tensioners, as well as control units and sensors for the restraint systems, may be installed in the following areas of your vehicle:

- Doors
- Door pillars

- Door sills
- Seats
- Cockpit
- Instrument cluster
- Centre console

- ▶ Do not install accessories such as audio systems in these areas.
- ▶ Do not carry out repairs or welding.
- ▶ Have accessories retrofitted at a qualified specialist workshop.

You could jeopardise the operating safety of your vehicle if you use parts, tyres and wheels as well as accessories relevant to safety which have not been approved by Mercedes-Benz. Safety-relevant systems, e.g. the brake system, may malfunction. Only use Mercedes-Benz GenuineParts or parts of equal quality. Only use tyres, wheels and accessory parts that have been specifically approved for your vehicle model.

Mercedes-Benz tests genuine parts and conversion parts and accessory parts that have been specifically approved for your vehicle model for

their reliability, safety and suitability. Despite ongoing market research, Mercedes-Benz is unable to assess other parts. Mercedes-Benz therefore accepts no responsibility for the use of such parts in Mercedes-Benz vehicles, even if they have been officially approved or independently approved by a testing centre.

Certain parts are only officially approved for installation or modification if they comply with legal requirements. All Mercedes-Benz GenuineParts meet the approval requirements. The use of non-approved parts may invalidate the vehicle's general operating permit.

This is the case in the following situations:

- A change of the vehicle type from that for which the vehicle's general operating permit was granted.
- If other road users could be endangered.
- If the exhaust gas or noise levels are adversely affected.

Always specify the vehicle identification number (VIN) (→ page 366) when ordering Mercedes-Benz GenuineParts.

Owner's Manual

This Owner's Manual describes all models and all standard and optional equipment available for your vehicle at the time of this Owner's Manual going to press. Country-specific differences are possible. Note that your vehicle may not be fitted with all features described. This is also the case for systems and functions relevant to safety. Therefore, the equipment on your vehicle may differ from that in the descriptions and illustrations.

The original purchase contract documentation for your vehicle contains a list of all of the systems in your vehicle.

Should you have any questions concerning equipment and operation, please consult a Mercedes-Benz service centre.

The Owner's Manual and Service Booklet are important documents and should be kept in the vehicle.

Operating safety

⚠ WARNING Risk of accident due to malfunctions or system failures

If you do not have the prescribed service/maintenance work or any required repairs carried out, this could result in malfunctions or system failures.

- ▶ Always have the prescribed service/maintenance work as well any required repairs carried out at a qualified specialist workshop.

⚠ WARNING Risk of accident or injury due to incorrect modifications on electronic component parts

Modification to electronic components, their software or wiring could impair their function and/or the function of other networked component parts. In particular, systems relevant to safety could also be affected.

As a result, these may no longer function properly and/or jeopardise the operating safety of the vehicle.

- ▶ Never tamper with the wiring and electronic component parts or their software.
- ▶ You should have all work on electrical and electronic components carried out at a qualified specialist workshop.

If you modify the on-board electronics, the general operating permit is rendered invalid.

⚠ WARNING Risk of fire due to flammable materials on hot parts of the exhaust system

Flammable material such as leaves, grass or twigs may ignite if they come into contact with hot parts of the exhaust system.

- ▶ When driving on unpaved roads or off-road, regularly check the vehicle underside.

- ▶ Remove trapped plants or other flammable material, in particular.
- ▶ If there is damage, consult a qualified specialist workshop immediately.

! NOTE Damage to the vehicle

Damage to the vehicle may occur in the following cases:

- the vehicle becomes grounded, e.g. on a high kerb or an unpaved road.
- the vehicle is driven too fast over an obstacle, e.g. a kerb, speed bump or pothole.
- a heavy object strikes the underbody or chassis components.

In situations such as this, the body, the underbody, chassis components, wheels or tyres could be damaged without the damage being visible. Components damaged in this way can unexpectedly fail or, in the case of an accident, no longer withstand the strain they are designed to.

If the underbody panelling is damaged, flammable materials such as leaves, grass or twigs can gather between the underbody and the underbody panelling. These materials may ignite if they come into contact with hot parts on the exhaust system.

- ▶ Have the vehicle checked and repaired immediately at a qualified specialist workshop.

or

- ▶ If driving safety is impaired while continuing your journey, pull over and stop the vehicle immediately, paying attention to road and traffic conditions, and contact a qualified specialist workshop.

Declaration of Conformity

Electromagnetic compatibility

The electromagnetic compatibility of the vehicle components has been checked and certified according to the currently valid version of Regulation ECE-R 10.

Wireless vehicle components

The following information applies to all components of the vehicle and the information systems and communication devices integrated into the vehicle which receive and/or transmit radio waves:

The components of this vehicle that receive and/or transmit radio waves are compliant with the basic requirements and all other relevant conditions of Directive 2014/53/EU. You can obtain further information from a Mercedes-Benz Service Centre.

Jack

Copy and translation of the original declaration of conformity:

EC declaration of conformity

1.

The signatory, as a representative
Manufacturer:

BRANO a.s.

74741 Hradec nad Moravicí, Opavská 1000,

Czech Republic

ID No.: 64-387-5933

VAT Reg. No.: CZ64-387-5933

declares, as our sole responsibility, that the product:

2. a)

Description:

Jack

Type, number:

A) A 164 580 02 18, A 166 580 01 18

B) A 240 580 00 18

C) A 639 580 02 18

Manufacture year: 2015

Fulfils all relevant conditions

Directive No. 2006/42/EC

b)

Description and purpose of use:

The jack is only intended for raising the specified vehicle in accordance with the operating instructions affixed to the jack.

3.

Reference data of the harmonised standards or specifications

A) ISO 4063, EN ISO 14341-A, DBL 7382.20, MBN 10435, AS 2693

B) ISO 4063, ISO 14341-A, DBL 7392.10, MBN 10435

C) DBL 7392.10, DBL 8230.10

The technical documentation of the product is stored at the manufacturer's plant. Representative for the compilation of the technical documentation: Director of the Technical Department Brano a.s.

4.

Hradec nad Moravicí

City

5.

05.05.2015

Date

Signed by

Director of Quality

TIREFIT kit

Copy and translation of the original declaration of conformity:

EC declaration of conformity

In accordance with EC directive 2006/42/EC

We hereby declare that the product

Product designation: Daimler electric air pump

Model designation: 0851ve, DT/UW 200046

MB part no.: A 000 583 8200

complies with the following relevant regulations: 2004/108/EC

Applied harmonised standards, in particular:

DIN EN 55014-1

DIN EN 55014-2:2009-06

Manufacturer: Dunlop Tech GmbH

Address: Birkenhainerstrasse 77, 63450 Hanau, Germany

Authorised representative: IMS dept.

Date: June 2015

Signature: IMS-AM, IMS-AE-L

Diagnostics connection

The diagnostics connection is only intended for the connection of diagnostic devices at a qualified specialist workshop.

⚠ WARNING Risk of accident due to connecting devices to the diagnostics connection

If you connect equipment to a diagnostics connection in the vehicle, it may affect the operation of vehicle systems.

As a result, the operating safety of the vehicle could be affected.

- ▶ Only connect equipment to a diagnostics connection in the vehicle which is approved for your vehicle by Mercedes-Benz.

⚠ WARNING Risk of accident due to objects in the driver's footwell

Objects in the driver's footwell may impede pedal travel or block a depressed pedal.

This jeopardises the operating and road safety of the vehicle.

- ▶ Stow all objects in the vehicle securely so that they cannot get into the driver's footwell.
- ▶ Always fit the floor mats securely and as prescribed in order to ensure that there is always sufficient room for the pedals.
- ▶ Do not use loose floor mats and do not place floor mats on top of one another.

! NOTE Battery discharging from using devices connected to the diagnostics connection

Using devices at the diagnostics connection drains the battery.

- ▶ Check the charge level of the battery.
- ▶ If the charge level is low, charge the battery, e.g. by driving a considerable distance.

Connecting equipment to the diagnostics connection can lead to emissions monitoring information being reset, for example. This may lead to the vehicle failing to meet the requirements of the next emissions inspection during the main inspection.

Qualified specialist workshop

A qualified specialist workshop has the necessary special skills, tools and qualifications to correctly carry out any necessary work on your vehicle. This particularly applies to work relevant to safety.

Always have the following work carried out on your vehicle at a qualified specialist workshop:

- work relevant to safety
- service and maintenance work
- repair work
- modifications as well as installations and conversions
- work on electronic components

- **Vehicles with 48 V on-board electrical system (EQ-boost technology):** work on high voltage components of the 48 V on-board electrical system

Mercedes-Benz recommends a Mercedes-Benz service centre.

Vehicle registration

Mercedes-Benz may ask its service centres to carry out technical inspections on certain vehicles. The quality or safety of the vehicle is improved as a result of the inspection.

Mercedes-Benz can only inform you about vehicle checks if Mercedes-Benz has your registration data.

It is possible that your vehicle has not yet been registered in your name in the following cases:

- If your vehicle was not purchased at an authorised specialist dealer.
- If your vehicle has not yet been examined at a Mercedes-Benz service centre.

It is advisable to register your vehicle with a Mercedes-Benz service centre.

Inform Mercedes-Benz as soon as possible about any change in address or vehicle ownership. You can do this at a Mercedes-Benz service centre, for example.

Correct use of the vehicle

If you remove any warning stickers, you or others could fail to recognise certain dangers. Leave warning stickers in position.

When using the vehicle, observe the following information:

- the safety notes in this manual
- technical data for the vehicle
- traffic rules and regulations
- laws and safety standards pertaining to motor vehicles

Implied warranty

! **NOTE** Damage to the vehicle arising from violation of these operating instructions.

Damage to the vehicle can arise from violation of these operating instructions.

This damage is not covered either by the Mercedes-Benz implied warranty or by the New- or Used-Vehicle Warranty.

▶ Follow the instructions in these operating instructions on proper operation of your vehicle as well as on possible vehicle damage.

QR code for rescue card

The QR code is secured in the fuel filler flap and on the opposite side on the B-pillar. In the event of an accident, rescue services can use the QR code to quickly find the appropriate rescue card for your vehicle. The current rescue card contains the most important information about your

vehicle in a compact form, e.g. the routing of the electric lines.

Further information can be obtained at <http://www.mercedes-benz.de/qrcode>.

Vehicle data storage

Information from electronic control units

Electronic control units are fitted in your vehicle. Some of these are necessary for the safe operation of your vehicle, while some assist you when driving (driver assistance systems). In addition, your vehicle provides convenience and entertainment functions, which are also made possible by electronic control units.

Electronic control units contain data memories which can temporarily or permanently store technical information about the vehicle's operating status, component loads, maintenance requirements and technical events or faults.

In general, this information documents the state of a component part, a module, a system or the surroundings such as:

- operating statuses of system components (e.g. fluid levels, battery status, tyre pressure)
- status messages concerning the vehicle and its individual components (e.g. number of wheel revolutions/speed, deceleration, lateral acceleration, display of the fastened seat belts)
- malfunctions or defects in important system components (e.g. lights, brakes)
- information on vehicle damage events
- system reactions in special driving situations (e.g. airbag deployment, intervention of stability control systems)
- ambient conditions (e.g. temperature, rain sensor)

In addition to providing the actual control unit function, this data assists the manufacturer in detecting and rectifying faults and optimising vehicle functions. The majority of this data is

temporary and is only processed in the vehicle itself. Only a small portion of the data is stored in the event or fault memory.

When your vehicle is serviced, technical data from the vehicle can be read out by service network employees or third parties. Services include repair services, maintenance processes, warranty events and quality assurance measures, for example. The read out is performed via the legally prescribed port for OBD ("on-board diagnostics") in the vehicle. The respective service network locations or third parties collect, process and use the data. They document technical statuses of the vehicle, assist in finding faults and improving quality and are transmitted to the manufacturer, if necessary. Furthermore, the manufacturer is subject to product liability. For this, the manufacturer requires technical data from vehicles.

Fault memories in the vehicle can be reset by a service outlet as part of repair or maintenance work.

They can enter data into the vehicle's convenience and infotainment functions themselves as part of the selected equipment.

This includes, for example:

- multimedia data such as music, films or photos for playback in an integrated multimedia system
- address book data for use in connection with an integrated hands-free system or an integrated navigation system
- entered navigation destinations
- data about the use of Internet services

This data can be stored locally in the vehicle or is located on a device which you have connected to the vehicle. If this data is stored in the vehicle, you can delete it at any time. This data can only be transmitted to third parties upon your request with particular regard to the scope of use of online services according to your selected settings.

You can store or change convenience settings/individualisations in the vehicle at any time.

Depending on the equipment, this includes, for example:

- seat and steering wheel position settings
- suspension and climate control settings

- individualisations such as interior lighting

If your vehicle is accordingly equipped, you can connect your smartphone or another mobile end device to the vehicle. You can control them via the control elements integrated in your vehicle. Images and audio from the smartphone can be output via the multimedia system. Certain information is simultaneously transmitted to your smartphone.

Depending on the respective integration type, this includes, for example:

- general vehicle information
- position data

This enables the use of selected smartphone Apps, e.g. navigation or music playback. There is no further interaction between the smartphone and the vehicle; in particular, vehicle data is not directly accessible. The type of further data processing is determined by the provider of the App used. The respective App and your smartphone's operating system determine whether changes can be made to the settings and which settings can be changed.

Service providers

Wireless network connection

If your vehicle has a wireless network connection, it enables data to be exchanged between your vehicle and additional systems. The wireless network connection is enabled via the vehicle's transmission and reception unit or via connected mobile end devices (e.g. smartphones). Online functions can be used via the wireless network connection. This includes online services and applications/Apps provided by the manufacturer or other providers.

Manufacturer's services

The manufacturer describes the respective functions and corresponding legal data protection information when suitable for the manufacturer's online services. Personal data may be used for the provision of online services. Data is exchanged via a secure connection, e.g. to the manufacturer's designated IT systems. Personal data is collected, processed and used via the provision of services exclusively on the basis of legal permissions or with prior consent.

The services and functions (sometimes subject to a fee) can usually be activated or deactivated. In some cases, this also applies to the entire vehicle's data connection. This excludes, in particular, legally prescribed functions and services.

Third party services

If it is possible to use online services from other providers, these services are subject to the data protection and terms of use of the responsible provider. The manufacturer has no influence on the content exchanged.

Please enquire, therefore, about the type, scope and purpose of the collection and use of personal data as part of third party services from their respective provider.

Copyright

Information on free and open source software licences for your vehicle's software can be found on the data storage medium in your vehicle document wallet and on the Internet together with updates:

<http://www.mercedes-benz.com/opensource>

Restraint system

Protection by the restraint system

The restraint system includes the following:

- Seat belt system
- Airbags
- Child restraint system
- Child seat securing system

The restraint system can reduce the risk of vehicle occupants coming into contact with parts of the vehicle interior in the event of an accident. In the event of an accident, the restraint system can also reduce the forces to which the vehicle occupants are subjected.

A seat belt can only provide the best level of protection if it is worn correctly. Depending on the detected accident situation, seat belt tensioners and/or airbags supplement the protection offered by a correctly worn seat belt. Seat belt tensioners and/or airbags are not deployed in every accident.

In order for the restraint system to provide the intended level of protection, each vehicle occupant must observe the following information:

- Fasten seat belts correctly.
- Sit in an almost upright seat position with their back against the seat backrest.
- Sit with their feet resting on the floor, if possible.
- Always secure persons under 1.50 m tall in an additional restraint system suitable for Mercedes-Benz vehicles.

However, no system available today can completely eliminate injuries and fatalities in every accident situation. In particular, the seat belt and airbag generally do not protect against objects penetrating the vehicle from the outside. It is also not possible to completely rule out the risk of injury caused by the airbag deploying.

Reduced restraint system protection

⚠ WARNING Risk of injury or death from modifications to the restraint system

The restraint system can no longer function correctly after alterations have been made.

The restraint system may then not protect the vehicle occupants as intended by failing in an accident or triggering unexpectedly, for example

- ▶ Never alter the parts of the restraint system.
- ▶ Never tamper with the wiring or any electronic component parts or their software.

If it is necessary to modify the vehicle to accommodate a person with disabilities, contact a qualified specialist workshop.



Mercedes-Benz recommends that you only use driving aids which have been approved specifically for your vehicle by Mercedes-Benz.

Restraint system functionality

When the ignition is switched on, a system self-test is performed, during which the  restraint system warning lamp lights up. It goes out no later than a few seconds after the vehicle is started. The components of the restraint system are then functional.

Malfunctioning restraint system

A malfunction has occurred in the restraint system if:

- The  restraint system warning lamp does not light up when the ignition is switched on.
- The  restraint system warning lamp lights up continuously or repeatedly during a journey.

⚠ WARNING Risk of injury or fatal injury due to a malfunction in the restraint system

If the restraint system is malfunctioning, restraint system components may be triggered unintentionally or might not be triggered at all in the event of an accident. This may affect the seat belt tensioner or airbag, for example.

- ▶ Have the restraint system checked and repaired immediately at a qualified specialist workshop.

Function of the restraint system in an accident

How the restraint system works is determined by the severity of the impact detected and the type of accident anticipated:

- Frontal impact
- Rear impact
- Side impact
- Rollover

The activation thresholds for the components of the restraint system are determined based on the evaluation of the sensor values measured at various points in the vehicle. This process is preemptive in nature. The triggering/deployment of the components of the restraint system should take place in good time at the start of the collision.

Factors which can only be seen and measured after a collision has occurred cannot play a decisive role in airbag deployment, nor do they provide an indication of airbag deployment.

The vehicle may be deformed significantly without an airbag being deployed. This is the case if only parts which are relatively easily deformed are affected and the rate of vehicle deceleration is not high. Conversely, an airbag may be deployed even though the vehicle suffers only minor deformation. If very rigid vehicle parts such as longitudinal members are hit, for example, the vehicle deceleration may be high enough for this to happen.

The components of the restraint system can be activated or deployed independently of each other:

Component	Detected deployment situation
Seat belt tensioners	Frontal impact, rear impact, side impact, rollover
Driver's airbag, front passenger airbag	Frontal impact
Knee airbag	Frontal impact
Side impact airbag	Side impact
Window airbag	Side impact, rollover, frontal impact
Belt airbag	Frontal impact
PRE-SAFE® Impulse Side	Side impact

The front passenger airbag can only be deployed in an accident if the PASSENGER AIR BAG OFF

indicator lamp is off. If the front passenger seat is occupied, make sure, both before and during the journey, that the status of the front passenger airbag is correct (→ page 42).

⚠ WARNING Risk of burns from hot airbag components

The airbag parts are hot after an airbag has been deployed.

- ▶ Do not touch the airbag parts.
- ▶ Have a deployed airbag replaced at a qualified specialist workshop as soon as possible.

Mercedes-Benz recommends that you have the vehicle towed to a qualified specialist workshop after an accident. Take this into account, particularly if a seat belt tensioner is triggered or an airbag deployed.

If the seat belt tensioners are triggered or an airbag is deployed, you will hear a bang, and a small amount of powder may also be released:

- The bang will not generally affect your hearing.

- In general, the powder released is not hazardous to health but may cause short-term breathing difficulties to persons suffering from asthma or other pulmonary conditions. Provided it is safe to do so, leave the vehicle immediately or open the window in order to prevent breathing difficulties.

Seat belts

Protection provided by the seat belt

Always fasten your seat belt correctly before starting a journey. A seat belt can only provide the best level of protection if it is worn correctly.

⚠ WARNING Risk of injury or death due to incorrectly fastened seat belt

If the seat belt is not worn correctly, it cannot perform its intended protective function.

In addition, an incorrectly fastened seat belt can also cause injuries, for example, in the event of an accident or when braking or changing direction suddenly.

▶ Always ensure that all vehicle occupants have their seat belts fastened correctly and are sitting properly.

In order for the correctly worn seat belt to provide the intended level of protection, each vehicle occupant must observe the following information:

- The seat belt must not be twisted and must fit tightly and snugly across the body.
- The seat belt must be routed across the centre of the shoulder and as low down across the hips as possible.
- The shoulder section of the seat belt should not touch your neck nor be routed under your arm or behind your back.
- Avoid wearing bulky clothing, e.g. a winter coat.
- Push the lap belt down as far as possible across your hips and pull tight with the shoulder section of the belt. Never route the lap belt across your abdomen.
- Never route the seat belt across sharp, pointed, abrasive or fragile objects.

- Only one person should use each seat belt at any one time. Never allow babies and children to travel sitting on the lap of another vehicle occupant.
- Never secure objects with a seat belt if the seat belt is also being used by one of the vehicle's occupants. Always observe the instructions for loading the vehicle when securing objects, luggage or loads (→ page 107).
Also ensure that no objects, e.g. a cushion, are ever placed between a person and the seat.

If children are travelling in the vehicle, be sure to observe the instructions and safety notes on "Children in the vehicle" (→ page 46).

Reduced seat belt protection

▲ WARNING Risk of injury or death due to incorrect seat position

The seat belt does not offer the intended level of protection if you have not moved the seat backrest to an almost vertical position.

When braking or in the event of an accident, you could slide underneath the seat belt and sustain abdominal or neck injuries, for example.

- ▶ Adjust the seat properly before beginning your journey.
- ▶ Always ensure that the seat backrest is in an almost vertical position and that the shoulder section of your seat belt is routed across the centre of your shoulder.

⚠ WARNING Risk of injury or death when additional restraint systems are not used for persons with a smaller build

Persons under 1.50 m tall cannot wear the seat belt correctly without a suitable additional restraint system.

If the seat belt is not worn correctly, it cannot perform its intended protective function. In addition, an incorrectly fastened seat belt can also cause injuries, for example, in the event of an accident or when braking or changing direction suddenly.

- ▶ Always secure persons under 1.50 m tall in a suitable restraint system.

⚠ WARNING Risk of injury or death due to blocked seat belt buckle or seat belt anchorage

Objects next to the front seat that block the seat belt buckle or the moving seat belt anchorage on the front seat impair the function of the seat belt tensioners.

The seat belt tensioners may not function as intended and the seat belt may no longer provide the intended protection.

- ▶ Before starting the journey, make sure that there are no objects around the seat belt buckle or between the front seat and door.

⚠ WARNING Risk of injury or death due to damaged or modified seat belts

Seat belts cannot provide protection in the following situations:

- If the seat belts are damaged, modified, extremely dirty, bleached or dyed
- If the seat belt buckle is damaged or extremely dirty
- If the seat belt tensioners, seat belt anchorages or seat belt retractors have been modified

Seat belts may be damaged in an accident, although the damage may not be visible, e.g. due to splinters of glass.

Modified or damaged seat belts may tear or fail, e.g. in an accident.

Modified seat belt tensioners could accidentally trigger or fail to function as intended.

- ▶ Never modify the seat belts, seat belt tensioners, seat belt anchorages or seat belt retractors.
- ▶ Make sure that the seat belts are undamaged, not worn and clean.
- ▶ Always have the seat belts checked immediately after an accident at a qualified specialist workshop.

Mercedes-Benz recommends that you only use seat belts which have been approved specifically for your vehicle by Mercedes-Benz.

⚠ WARNING Risk of injury or death from deployed pyrotechnic seat belt tensioners

Pyrotechnic seat belt tensioners that have been deployed are no longer operational and are unable to perform their intended protective function.

- ▶ Therefore, have deployed pyrotechnic seat belt tensioners immediately replaced at a qualified specialist workshop.

Mercedes-Benz recommends that you have the vehicle towed to a qualified specialist workshop after an accident.

- ! **NOTE** Damage caused by trapping the seat belt

If an unused seat belt is not fully retracted, it may become trapped in the door or in the seat mechanism.

- ▶ Always ensure that an unused seat belt is fully retracted.

Information on the belt airbag in the rear seat belt

The BELTBAG identification indicates that a rear seat belt is equipped with a belt airbag.

When activated, the belt airbag increases the protected area of the vehicle occupant's ribcage.

- ! **WARNING** Risk of injury or death due to use of a non-approved child restraint system

In an accident, the belt airbag may damage a non-approved child restraint system or a child restraint system which has not been approved for use in conjunction with the belt airbag.

As a result, the child restraint system may not be able to provide the intended level of protection.

For safety reasons, Mercedes-Benz recommends that you only use a child restraint system which has been tested and approved by Mercedes-Benz in combination with a belt airbag.



Information on child restraint systems (→ page 61).

Fastening and adjusting seat belts

If the seat belt is pulled quickly or sharply, the seat belt retractor locks. The seat belt strap cannot be pulled out any further.



- ▶ Always engage seat belt tongue ② of the seat belt into seat belt buckle ① of the corresponding seat.

- ▶ Press and hold the seat belt outlet release and slide seat belt outlet  into the desired position.
- ▶ Let go of the seat belt outlet release and ensure that seat belt outlet  locks into position.

Vehicles with PRE-SAFE®: if the front seat belt is not pulled tight across your body, the seat belt adjustment may automatically apply a certain tightening force. Do not hold the seat belt tightly while it is adjusting. You can activate and deactivate the seat belt adjustment function using the multimedia system.

Vehicles with automatic front passenger front airbag deactivation system:

! **NOTE** Deployment of the seat belt tensioner and side impact airbag when the front passenger seat is unoccupied

If the seat belt tongue is engaged in the seat belt buckle of the unoccupied front passenger seat, the seat belt tensioner and the side impact airbag may also deploy in the

event of an accident along with other systems.

- ▶ Only one person should use each seat belt at any one time.

Vehicles without automatic front passenger front airbag deactivation system:

! **NOTE** Deployment of the seat belt tensioner when the front passenger seat is unoccupied

If the seat belt tongue is engaged in the seat belt buckle of the unoccupied front passenger seat, the seat belt tensioner may also deploy in the event of an accident along with other systems.

- ▶ Only one person should use each seat belt at any one time.

Releasing a seat belt

- ▶ Press the release button in the seat belt buckle and guide the seat belt back with the seat belt tongue.

Activating or deactivating seat belt adjustment via the multimedia system

Multimedia system:

 [Vehicle](#) ▶ [Vehicle settings](#) ▶ [Belt adjustment](#)

- ▶ Activate or deactivate the function.

Seat belt warning function for the driver and front passenger

The  seat belt warning lamp in the instrument display is a reminder that all vehicle occupants must wear their seat belts correctly.

In addition, an acoustic warning tone may sound. As soon as the driver and front passenger fasten their seat belts, the seat belt warning goes out.

Function of the rear seat belt status display

The rear seat belt status display is only available for certain countries.



The rear seat belt status display informs you which rear seat belt is not fastened.

You can immediately dismiss the rear seat belt status display using the back button on the left-hand side of the steering wheel (→ page 253).

Airbags

Overview of airbags

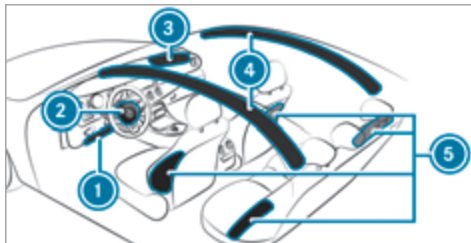

- ① Knee airbag
- ② Driver's airbag
- ③ Front passenger front airbag
- ④ Windowbag
- ⑤ Side impact airbag

The installation location of an airbag is identified by the AIRBAG symbol.

When activated, an airbag can provide additional protection for the respective vehicle occupant.

AIRBAG	Potential protection for ...
Knee airbag	Thigh, knee and lower leg
Driver's airbag, front passenger front airbag	Head and ribcage
Windowbag	Head
Side impact airbag	Ribcage, also pelvis for front seat occupants

The front passenger front airbag can only be deployed in an accident if the PASSENGER AIRBAG OFF indicator lamp is off. If the front passenger seat is occupied, make sure, both before and during the journey, that the status of the front passenger airbag is correct (→ page 42).

! **NOTE** Important points to remember if the front passenger seat is unoccupied

In an accident, the components of the restraint system may deploy unnecessarily on the front passenger side if:

- There are heavy objects on the front passenger seat.
- The seat belt tongue is engaged in the seat belt buckle of the front passenger seat and the front passenger seat is unoccupied.

- ▶ Stow objects in a suitable place.
- ▶ Only one person should use each seat belt at any one time.

Protection by the airbags

Depending on the accident situation, an airbag may supplement the protection offered by a correctly fastened seat belt.

! **WARNING** Risk of injury or death due to incorrect seat position

If you deviate from the correct seat position, the airbag cannot perform its intended protective function and deployment may even cause further injuries.

To avoid hazardous situations, always make sure that all vehicle occupants:

- Have their seat belt fastened correctly, including pregnant women.
- Are seated properly and keep as far away as possible from the airbags.
- Observe the following information.
- ▶ Always make sure that there are no objects between the airbag and vehicle occupant.

To avoid the risks resulting from the deployment of an airbag, each vehicle occupant must observe the following information:

- Before starting your journey, adjust your seat correctly; the driver's seat and front

passenger seat should be moved as far back as possible.

When doing so, always observe the information on the correct driver's seat position (→ page 94).

- Only hold the steering wheel by the steering wheel rim. This allows the airbag to be fully deployed.
- Always lean against the seat backrest when the vehicle is in motion. Do not lean forwards or against the door or side window. You may otherwise be in the deployment area of the airbags.
- Always keep your feet on the floor. Do not put your feet on the cockpit, for example. Your feet may otherwise be in the deployment area of the airbag.
- If children are travelling in the vehicle, observe the additional notes (→ page 46).
- Always stow and secure objects correctly.

Objects in the vehicle interior may prevent an airbag from functioning correctly. Each vehicle occupant must always make sure of the following:

- There are no people, animals or objects between the vehicle occupants and an airbag.
- There are no objects between the seat, door and door pillar (B-pillar).
- There are no hard objects, e.g. coat hangers, hanging on the grab handles or coat hooks.
- There are no accessory parts, such as cup holders, attached to the vehicle within the deployment area of an airbag, e.g. on doors, side windows or side panelling.
- There are no heavy, sharp-edged or fragile objects in the pockets of your clothing. Store such objects in a suitable place.

Reduced airbag protection

⚠ WARNING Risk of injury from modifications to the airbag cover

If you modify an airbag cover or affix objects such as stickers to it, the airbag can no longer function correctly.

- ▶ Never modify an airbag cover and do not affix objects to it.

The installation location of an airbag is identified by the AIRBAG symbol (→ page 38).

⚠ WARNING Risk of injury or death due to the use of unsuitable seat covers

Unsuitable seat covers can obstruct or prevent the deployment of the airbags integrated into the seats.

Consequently, the airbags cannot protect vehicle occupants as they are designed to do. In addition, the operation of the automatic front passenger airbag shutoff could be restricted.

- ▶ You should only use seat covers that have been approved for the corresponding seats by Mercedes-Benz.

⚠ WARNING Risk of injury due to malfunctions of the sensors in the door panelling

Sensors to control the airbags are located in the doors. Modifications or work not performed correctly to the doors or door panelling, as well as damaged doors, can lead to the function of the sensors being impaired. The airbags might therefore not function properly any more.

Consequently, the airbags cannot protect vehicle occupants as they are designed to do.

- ▶ Never modify the doors or parts of the doors.
- ▶ Always have work on the doors or door panelling carried out at a qualified specialist workshop.

⚠ WARNING Risk of injury due to deployed airbag

A deployed airbag no longer offers any protection and cannot provide the intended protective function in the event of an accident.

- ▶ Have the vehicle towed to a qualified specialist workshop in order to have the deployed airbag replaced.

Have deployed airbags replaced immediately.

Status of the front passenger airbags

Function of the automatic front passenger front airbag deactivation system

The automatic front passenger front airbag deactivation system is able to detect whether the front passenger seat is occupied by a person or a child restraint system. The front passenger airbag is enabled or disabled accordingly.

When fitting a child restraint system to the front passenger seat, always make sure of the following:

- Ensure that the child restraint system is positioned correctly (→ page 54).
- Always observe the child restraint system manufacturer's installation instructions.
- Never place objects, e.g. cushions, under or behind the child restraint system.
- Fully retract the seat cushion length adjustment.
- The entire base of the child restraint system must always rest on the sitting surface of the front passenger seat.
- The backrest of the forward-facing child restraint system must, as far as possible, be resting on the seat backrest of the front passenger seat.
- The child restraint system must not touch the roof or be put under strain by the head restraints. Adjust the seat backrest inclination and the head restraint setting accordingly.

⚠ WARNING Risk of injury or death due to objects between the sitting surface and the child restraint system

Objects between the sitting surface and the child restraint system could affect the function of the automatic front passenger airbag shutoff.

This could result in the front passenger airbag not functioning as intended during an accident.

- ▶ Do not place any objects between the sitting surface and the child restraint system.
- ▶ The entire base of the child restraint system must always rest on the sitting surface of the front passenger seat.
- ▶ The backrest of the forward-facing child restraint system must, as far as possible, be resting on the seat backrest of the front passenger seat.
- ▶ Always comply with the child restraint system manufacturer's installation instructions.

A person on the front passenger seat must observe the following information:

- Fasten seat belts correctly.
- Sit in an almost upright seat position with their back against the seat backrest.
- Sit with their feet resting on the floor, if possible.

Otherwise, the front passenger airbag may be disabled by mistake, for example in the following situations:

- The front passenger transfers their weight by supporting themselves on a vehicle armrest.
- The front passenger sits in such a way that their weight is raised from the sitting surface.

⚠ WARNING Risk of injury or death due to deactivated front passenger airbag

If the PASSENGER AIRBAG OFF indicator lamp is lit, the front passenger airbag is disabled. It will not be deployed in the event of an accident and cannot perform its intended protective function.

A person in the front passenger seat could then, for example, come into contact with the vehicle interior, especially if the person is sitting too close to the cockpit.

If the front passenger seat is occupied, always ensure that:

- The classification of the person in the front passenger seat is correct and the front passenger airbag is enabled or disabled in accordance with the person in the front passenger seat.
 - The front passenger seat has been moved as far back as possible.
 - The person is seated correctly.
- ▶ Ensure, both before and during the journey, that the status of the front passenger airbag is correct.

Function of the PASSENGER AIR BAG indicator lamps



System self-test

When the ignition is switched on, a system self-test is performed during which the two PASSENGER AIR BAG ON and OFF indicator lamps light up simultaneously.

The status of the front passenger airbag is displayed after the system self-test:

- PASSENGER AIR BAG ON lights up for 60 seconds, subsequently both indicator lamps are off (PASSENGER AIR BAG ON and OFF): the front passenger airbag is able to deploy in the event of an accident.
- PASSENGER AIR BAG OFF lights up continuously: the front passenger airbag is disabled. It will then not be deployed in the event of an accident.

If the PASSENGER AIR BAG ON indicator lamp is off, only the PASSENGER AIR BAG OFF indicator lamp shows the status of the front passenger airbag. The PASSENGER AIR BAG OFF indicator lamp may be lit continuously or be off.

If the PASSENGER AIR BAG OFF indicator lamp and the  restraint system warning lamp light up simultaneously, the front passenger seat may not be used. Also in this case, do not install a child restraint system on the front passenger seat. Have the automatic front passenger airbag shutoff checked and repaired immediately at a qualified specialist workshop.

Status display

If the front passenger seat is occupied, ensure, both before and during the journey, that the status of the front passenger airbag is correct for the prevailing situation.

After fitting a rearward-facing child restraint system to the front passenger seat:

PASSENGER AIR BAG OFF must be lit continuously.

⚠ WARNING Risk of injury or death from using a rearward-facing child restraint system when the front passenger airbag is enabled

If you secure a child in a rearward-facing child restraint system on the front passenger seat and the PASSENGER AIR BAG OFF indicator lamp is off, the front passenger airbag can deploy in the event of an accident.

The child could be struck by the airbag.

Always ensure that the front passenger airbag is disabled. The PASSENGER AIR BAG OFF indicator lamp must be lit.

NEVER use a rearward facing child restraint on a seat protected by an ACTIVE FRONT AIRBAG in front of it; DEATH or SERIOUS INJURY to the CHILD can occur.

When fitting a child restraint system to the front passenger seat, observe the vehicle-specific information .

Depending on the child restraint system and the stature of the child, the PASSENGER AIR BAG OFF indicator lamp may be off. In this case, do not fit the rearward-facing child restraint system to the front passenger seat.

Instead, fit the rearward-facing child restraint system to a suitable rear seat.

After fitting a forward-facing child restraint system to the front passenger seat: depending on the child restraint system and the stature of the child, PASSENGER AIR BAG OFF may be lit continuously or be off. Always observe the following information.

⚠ WARNING Risk of injury or death due to incorrect positioning of the forward-facing child restraint system

If you secure a child in a forward-facing child restraint system on the front passenger seat and you position the front passenger seat too close to the cockpit, in the event of an accident, the child could:

- Come into contact with the vehicle interior if the PASSENGER AIR BAG OFF indicator lamp is lit, for example.
- Be struck by the airbag if the PASSENGER AIR BAG OFF indicator lamp is off.

▶ Always move the front passenger seat as far back as possible and fully retract the seat cushion length adjustment. Always make sure that the shoulder belt strap is correctly routed from the seat belt outlet on the vehicle to the shoulder belt guide on the child restraint system. The shoulder belt strap must be routed forwards and downwards from the seat belt outlet. If necessary, adjust

the seat belt outlet and the front passenger seat accordingly.

- ▶ Always observe the child restraint system manufacturer's installation instructions.

When fitting a child restraint system to the front passenger seat, observe the vehicle-specific information .

If a person is sitting in the front passenger seat: PASSENGER AIR BAG OFF may be lit continuously or be off, depending on the person's stature.

A person on the front passenger seat must always observe the following information:

- If the front passenger seat is occupied with an adult or a person with a stature corresponding to that of an adult, the PASSENGER AIR BAG OFF indicator lamp must be off. This indicates that the front passenger airbag is enabled.

If the PASSENGER AIR BAG OFF indicator lamp is lit continuously, an adult or person with a build corresponding to that of an adult

should not use the front passenger seat. Instead, they should use a rear seat.

- If the front passenger seat is occupied by a person of smaller stature (e.g. a teenager or small adult), the PASSENGER AIR BAG OFF indicator lamp either lights up continuously or remains off, depending on the result of the classification.
 - PASSENGER AIRBAG OFF is off: move the front passenger seat as far back as possible or a person of smaller stature should use a rear seat.
 - If the PASSENGER AIRBAG OFF indicator lamp is lit continuously: a person of smaller stature should not use the front passenger seat.

⚠ WARNING Risk of injury or death when the PASSENGER AIR BAG OFF indicator lamp is lit

If the PASSENGER AIR BAG OFF indicator lamp remains lit after the system self-test, the front passenger airbag is disabled. It will not be deployed in the event of an accident.

In this case, the front passenger airbag cannot perform its intended protective function, e.g. when a person is seated in the front passenger seat.

That person could, for example, come into contact with the vehicle interior, especially if the person is sitting too close to the cockpit.

If the front passenger seat is occupied, always ensure that:

- The classification of the person in the front passenger seat is correct and the front passenger airbag is enabled or disabled in accordance with the person in the front passenger seat.
- The person is seated properly with a correctly fastened seat belt.
- The front passenger seat has been moved as far back as possible.

Further related subjects:

- Child restraint system on the front passenger seat (→ page 52).

- Suitable positioning of the child restraint system (→ page 54).

PRE-SAFE® system

PRE-SAFE® (Pre-Crash Safety-System)

PRE-SAFE® is able to detect certain critical driving situations and implement pre-emptive measures to protect the vehicle occupants.

PRE-SAFE® can implement the following measures independently of each other:

- Tightening the seat belts on the driver's seat and front passenger seat.
- Closing the side windows.
- **Vehicles with sliding sunroof:** closing the sliding sunroof.
- **Vehicles with memory function:** moving the front passenger seat to a more favourable seat position.
- **Vehicles with multicontour seat:** increasing the air pressure in the seat side bolsters of the seat backrest.

- PRE-SAFE® Sound: provided that the multimedia system is switched on, generates a brief noise signal to stimulate the innate protective mechanism of a person's hearing.

! **NOTE** Damage caused by objects in the footwell or behind the seat

The automatic adjustment of the seat position may result in damage to the seat and/or the object.

▶ Stow objects in a suitable place.

Reversing the PRE-SAFE® system measures

If an accident did not occur, the pre-emptive measures that were taken are reversed.

You will need to perform certain settings yourself.

▶ If the seat belt pre-tensioning is not reduced, move the seat backrest back slightly. The locking mechanism releases.

Function of PRE-SAFE® PLUS (anticipatory occupant protection plus)

PRE-SAFE® PLUS can detect certain impacts, particularly an imminent rear impact, and take pre-emptive measures to protect the vehicle occupants. These measures cannot necessarily prevent an imminent impact.

PRE-SAFE® PLUS can implement the following measures independently of each other:

- Tightening the seat belts on the driver's seat and front passenger seat.
- Activating the rear hazard warning lights at a higher flashing frequency.
- Increasing brake pressure when the vehicle is stationary. This brake application is cancelled automatically when the vehicle pulls away.

If an accident did not occur, the pre-emptive measures that were taken are reversed.

System limitations

The system will not initiate any action in the following situations:

- when reversing
or
- when the vehicle is towing a trailer and there is a risk of a rear impact

The system will not initiate any braking application in the following situations:

- whilst driving
or
- when entering or exiting a parking space while using Active Parking Assist

Information on PRE-SAFE® Impulse Side

If an imminent side impact is detected, PRE-SAFE® Impulse Side can pre-emptively move the front-seat vehicle occupant's upper body towards the centre of the vehicle. It does this by rapidly inflating an air cushion in the outer seat side bolster of the seat backrest on the side on which the impact is anticipated. This increases

the distance between the door and the vehicle occupant.

If PRE-SAFE® Impulse Side has been deployed or is faulty, the [PRE-SAFE impulse side inoperative](#) See Owner's Manual display message is shown (→ page 382).

Children in the vehicle

Notes on the safe transportation of children

⚠ WARNING Risk of accident and injury due to children left unattended in the vehicle

If you leave children unattended in the vehicle, they may be able to set the vehicle in motion, for example by:

- Releasing the parking brake.
- Shifting the automatic transmission out of park position **P** or shifting the manual transmission into neutral.
- Starting the engine.

In addition, they may operate vehicle equipment.

- ▶ Never leave children and animals unattended in the vehicle.
- ▶ When leaving the vehicle, always take the key with you and lock the vehicle. This also applies to mobile phones if the "Digital Car Key in the smartphone" function is activated via the Mercedes connect me web app.

⚠ WARNING This poses an increased risk of death due to heat stroke or exposure to cold in the vehicle

If persons – particularly children – experience prolonged exposure to extremely high or low temperatures, this poses a risk of injury or even fatal injury.

- ▶ Never leave anyone – particularly children – unattended in the vehicle.

⚠ WARNING Risk of burns when the child seat is exposed to direct sunlight

If the child restraint system is exposed to direct sunlight or heat, parts could heat up. Children could suffer burns on these parts, particularly on metallic parts of the child restraint system.

- ▶ Always make sure that the child restraint system is not exposed to direct sunlight.
- ▶ Protect it with a blanket, for example.
- ▶ If the child restraint system has been exposed to direct sunlight, allow it to cool before securing a child into it.
- ▶ Never leave children unattended in the vehicle.

To improve protection for children younger than 12 years old or under 1.50 m in height, Mercedes-Benz recommends you observe the following information:

- Only secure children using a child restraint system which is appropriate to the height,

age and weight of the child and suitable for Mercedes-Benz vehicles. Be sure to observe the instructions for correct use of the child restraint system.

- Always install a child restraint system on a rear seat if possible.
- Only use the following securing systems for child restraint systems:
 - the seat belt system
 - the ISOFIX or i-Size mounting brackets
 - the Top Tether anchorages
- The manufacturer's installation instructions for the child restraint system.
- The warning labels in the vehicle interior and on the child restraint system.

⚠ WARNING Risk of injury or death caused by incorrect installation of the child restraint system

If the child restraint system is incorrectly installed on a suitable seating position, it cannot perform its intended protective function.

The child cannot be restrained in the event of an accident, heavy braking or a sudden change of direction.

- ▶ Always comply with the manufacturer's installation instructions for the child restraint system and its correct use.
- ▶ Make sure that the entire base of the child restraint system always rests on the sitting surface of the seat.
- ▶ Never place objects under or behind the child restraint system, e.g. cushions.
- ▶ Always use child restraint systems with the original cover designed for them.
- ▶ Always replace damaged covers with genuine covers.

⚠ WARNING Risk of accident caused by incorrectly installed child restraint systems

If the child restraint system is not correctly installed or secured, it could release in the

event of an accident, sudden braking or a sudden change in direction.

The child restraint system could be flung around and hit vehicle occupants. This poses an increased risk of injury or even death!

- ▶ Always install child restraint systems correctly, even when not in use.
- ▶ Always comply with the child restraint system manufacturer's installation instructions.

⚠ WARNING Risk of injury or death caused by the use of damaged child restraint systems

Child restraint systems or their retaining systems that have been subjected to a load in an accident may then not be able to perform their intended protective function.

The child cannot be restrained in the event of an accident, heavy braking or a sudden change of direction.

- ▶ Always replace child restraint systems immediately that have been damaged or involved in an accident.
- ▶ Have the securing systems for the child restraint systems checked at a qualified specialist workshop before installing a child restraint system again.

i Use Mercedes-Benz care products recommended by Mercedes-Benz to clean child restraint systems. Further information can be obtained at a qualified specialist workshop.

The following notes must be observed:

- When installing a child restraint system on the front passenger seat, the information on installing a child restraint system on the front passenger seat (→ page 52).
- Notes on attaching suitable child restraint systems (→ page 54).
- Notes on recommended child restraint systems (→ page 61).

- Instructions and safety notes on the automatic front passenger airbag shutoff (→ page 41).
- Safety notes on the seat belt (→ page 33).
- Information on the correct use of the seat belt (→ page 37).

ISOFIX and i-Size child seat securing systems

Information on the ISOFIX and i-Size child seat securing systems

⚠ WARNING Risk of injury or fatal injury if the child secured weighs more than the permissible gross weight for an ISOFIX or i-Size child restraint system

For ISOFIX or i-Size child restraint systems in which the child is secured using the seat belt integrated in the child restraint system, the permissible gross weight of the child and child restraint system is 33 kg.

If the child and the child restraint system together weigh more than 33 kg, the ISOFIX

or i-Size child restraint system with integrated seat belt does not offer sufficient protection. Too much load may be placed on the ISOFIX or i-Size child restraint systems and the child may not be restrained correctly in the event of an accident, for example.

- ▶ If the child and the child restraint system together weigh more than 33 kg, only use an ISOFIX or i-Size child restraint system with which the child is secured with the vehicle seat belt.
- ▶ Also secure the child restraint system with the Top Tether belt, if available.

Always comply with the information about the mass of the child restraint system

- in the manufacturer's installation and operating instructions for the child restraint system used
- on a label on the child restraint system, if present

Regularly check that the permissible gross mass of the child and child restraint system is still being adhered to.

When using a child restraint system, be sure to observe the manufacturer's installation and operating instructions as well as its correct use and the suitability of the seats for attaching a child restraint system.

ISOFIX and i-Size are standardised securing systems for special restraint systems. ISOFIX child restraint systems are approved in accordance with ECE R44, i-Size child restraint systems are approved in accordance with ECE R129.

Only child restraint systems that have been approved in accordance with ECE R44 may be attached to ISOFIX mounting brackets.

The following child restraint systems can be attached to i-Size securing rings:

- ISOFIX child restraint systems that are approved in accordance with ECE R44
- i-Size child restraint systems that are approved in accordance with ECE R129



- ① Symbol for fitting an ISOFIX child restraint system
- ② Symbol for fitting an i-Size child restraint system

Fitting ISOFIX and i-Size child seat attachments

⚠ WARNING Risk of injury or fatal injury if the child secured weighs more than the permissible gross weight for an ISOFIX or i-Size child restraint system

For ISOFIX or i-Size child restraint systems in which the child is secured using the seat belt integrated in the child restraint system, the permissible gross weight of the child and child restraint system is 33 kg.

If the child and the child restraint system together weigh more than 33 kg, the ISOFIX or i-Size child restraint system with integrated seat belt does not offer sufficient protection. Too much load may be placed on the ISOFIX or i-Size child restraint systems and the child may not be restrained correctly in the event of an accident, for example.

▶ If the child and the child restraint system together weigh more than 33 kg, only use an ISOFIX or i-Size child

restraint system with which the child is secured with the vehicle seat belt.

▶ Also secure the child restraint system with the Top Tether belt, if available.

Always comply with the information about the mass of the child restraint system

- in the manufacturer's installation and operating instructions for the child restraint system used
- on a label on the child restraint system, if present

Regularly check that the permissible gross mass of the child and child restraint system is still being adhered to.

When using a child restraint system, be sure to observe the manufacturer's installation and operating instructions as well as its correct use and the suitability of the seats for attaching a child restraint system.

Before every trip, make sure that the ISOFIX child restraint system or the i-Size child restraint system is engaged correctly in both ISOFIX or i-Size mounting brackets.

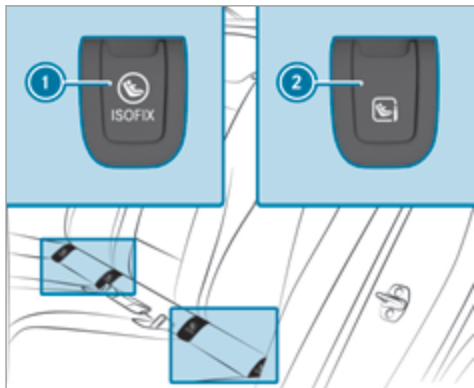

- ① ISOFIX mounting brackets
- ② i-Size mounting brackets

! **NOTE** Damage to the seat belt for the centre seat

When fitting a child restraint system, the seat belt for the centre seat could be damaged.

▶ Make sure that the seat belt is not trapped.

- ▶ Remove each cover for ISOFIX mounting brackets ① or i-Size mounting brackets ②.
- ▶ Attach the ISOFIX child restraint system to both ISOFIX mounting brackets ① or i-Size mounting brackets ②.

or

- ▶ Attach the i-Size child restraint system to both i-Size mounting brackets ②.
- ▶ After removing the child seat, replace each cover for ISOFIX mounting brackets ① or i-Size mounting brackets ②.

Securing Top Tether

! **WARNING** Risk of injury or death if the rear seat backrests are not locked after fitting Top Tether belts

If the rear seat backrests are not locked, they could fold forwards in the event of an acci-

dent, heavy braking or sudden changes of direction.

As a result, child restraint systems cannot perform their intended protective function. Rear seat backrests that are not locked can also cause additional injuries, e.g. in the event of an accident.

- ▶ Always lock rear seat backrests after fitting Top Tether belts.
- ▶ Observe the lock verification indicator.

If the seat backrest is not engaged and locked, this will be shown on the multifunction display on the instrument cluster.

The risk of injury can be reduced by Top Tether as Top Tether provides an additional connection between the child restraint system secured with ISOFIX or i-Size and the vehicle.

The child restraint system must be equipped with a Top Tether belt.

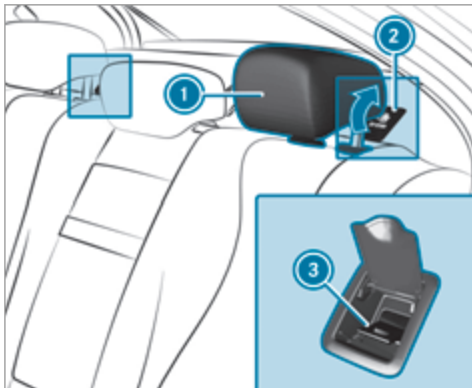

- ▶ If necessary, move head restraint ① upwards (→ page 101).
- ▶ Fold up cover ② of Top Tether anchorage ③.
- ▶ Fit the ISOFIX or i-Size child restraint system with Top Tether. Always comply with the child restraint system manufacturer's installation instructions when doing so.

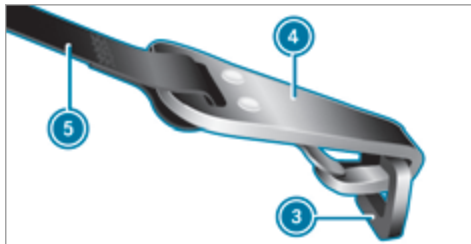

- ▶ Route Top Tether belt ⑤ under head restraint ① between the two head restraint bars.
- ▶ Hook Top Tether hook ④ of Top Tether belt ⑤ without twisting into Top Tether anchorage ③.
- ▶ Tension Top Tether belt ⑤. Always comply with the child restraint system manufacturer's installation instructions when doing so.
- ▶ Fold down cover ② of Top Tether anchorage ③.
- ▶ If necessary, slide head restraint ① downwards (→ page 101). Make sure that you do

not interfere with the routing of Top Tether belt ⑤.

Child restraint systems on the front passenger seat

Notes on child restraint systems on the front passenger seat

Accident statistics show that children secured in the rear seats are safer than children secured in the front seats. For this reason, Mercedes-Benz strongly advises that you install a child restraint system on a rear seat.

If it is absolutely necessary to install a child restraint system on the front passenger seat, always observe the information on the automatic front passenger airbag shutoff (→ page 41).

By doing this, you can avoid risks caused by:

- A child restraint system that is not detected by the automatic front passenger airbag shutoff.
- The unintentionally disabled front passenger airbag.

- Incorrect positioning of the child restraint system.



Warning notice on the front-passenger sun visor:

⚠ WARNING Risk of injury or death from using a rearward-facing child restraint system when the front passenger airbag is enabled

If you secure a child in a rearward-facing child restraint system on the front passenger seat and the PASSENGER AIR BAG OFF indicator lamp is off, the front passenger airbag can deploy in the event of an accident.

The child could be struck by the airbag.

Always ensure that the front passenger airbag is disabled. The PASSENGER AIR BAG OFF indicator lamp must be lit.

NEVER use a rearward facing child restraint on a seat protected by an ACTIVE FRONT AIRBAG in front of it; DEATH or SERIOUS INJURY to the CHILD can occur.

If the PASSENGER AIR BAG OFF indicator lamp goes out, the front passenger airbag is enabled. Be sure to observe the notes on the safe transportation of children (→ page 46).

Notes on vehicles without the automatic front passenger front airbag deactivation system

Vehicles without automatic front passenger front airbag deactivation system have a special sticker affixed to the side of the cockpit on the front passenger side.



Never install a rearward-facing child restraint system on the front passenger seat:

Make sure you observe the following information:

- On forward-facing and rearward-facing child restraint systems on the front passenger seat (→ page 54).
- On attaching suitable child restraint systems (→ page 54).

Notes on forward-facing and rearward-facing child restraint systems on the front passenger seat

When using a rearward-facing child restraint system on the front passenger seat, the front passenger front airbag must always be disabled. This is only the case if the PASSENGER AIR BAG OFF indicator lamp is lit continuously (→ page 42).

When using the child restraint system on the front passenger seat, it is essential to observe the following:

- Move the front passenger seat as far back as possible.
- Set the seat backrest to an almost vertical position.
- Retract the seat cushion length as far as possible.
- The entire base of the child restraint system must always rest on the sitting surface of the front passenger seat.
- The backrest of the forward-facing child restraint system must, as far as possible, be resting on the seat backrest of the front

passenger seat. The child restraint system must not touch the roof or be put under strain by the head restraints.

- If necessary, adjust the angle of the seat backrest and the head restraint position accordingly.
- Adjust the seat cushion inclination so that the front edge of the seat cushion is in the highest position and the rear edge of the seat cushion is in the lowest position.
- Always make sure that the shoulder belt strap is correctly routed from the seat belt outlet of the vehicle to the shoulder belt guide on the child restraint system. The shoulder belt strap must be routed forwards and downwards from the seat belt outlet.
- If necessary, adjust the seat belt outlet and the front passenger seat accordingly.
- Never place objects under or behind the child restraint system, e.g. cushions.

Always comply with the manufacturer's installation and operating instructions for the child restraint system used, and the notes on fitting suitable child restraint systems (→ page 54).

Suitability of the seats for child restraint systems

Notes on attaching suitable child restraint systems

Only child restraint systems with the following ECE standards are permitted for use in the vehicle:

- ECE R44
- ECE-R129 (i-Size child restraint systems)

Examples of approval labels on child restraint systems:

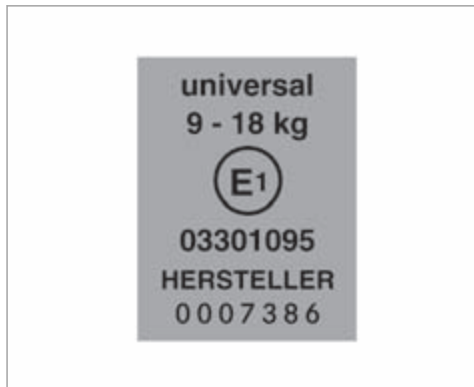

Label for child restraint systems in accordance with ECE R44

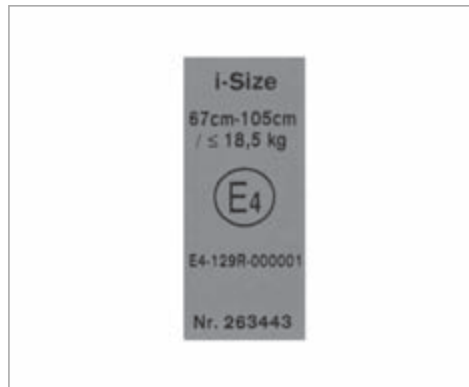

Label for child restraint systems in accordance with ECE R129

ISOFIX or i-Size child restraint systems of the following "Universal" category can be used, in accordance with the tables on suitability of seats for the attachment of child restraint systems, on seats marked U, UF, IUF or i-U.

Semi-universal child restraint systems are indicated by the text "semi-universal" on the approval label. They can only be used if the vehicle and the seat are listed in the child restraint system manufacturer's vehicle model list.

Notes on the suitability of seats for attaching belt-secured child restraint systems

Observe the following information:

- **When using a baby car seat of the category 0/0+ and a rearward-facing child restraint system on a rear seat:** adjust the driver's and front passenger seat such that the seat does not touch the child restraint system.
- **When using a forward-facing child restraint system of category I:** remove the head restraint from the respective seat, if possible. In addition, the seat backrest of the child restraint system must, as far as possible, lie flat against the backrest of the vehicle seat.
- When you remove the child restraint system, fit the head restraint immediately and adjust all the head restraints again correctly.

- For certain child restraint systems in weight categories II or III, there might be restrictions in the maximum size setting, e.g. due to possible contact with the roof.
- Make sure that the child's feet do not touch the front seat. If necessary, move the front seat forward slightly.
- The child restraint system must not touch the roof or be put under strain by the head restraints. Adjust the head restraints accordingly.

- Observe the manufacturer's installation instructions for the child restraint system.

Legend for the table:

X	Not suitable for children in this weight category.
U	Suitable for child restraint systems of the "Universal" category in this weight category.

UF	Suitable for forward-facing child restraint systems of the "Universal" category in this weight category.
L	Suitable for semi-universal child restraint systems according to the table in "Recommended child restraint systems", or if the vehicle and the seat are listed in the child restraint system manufacturer's vehicle model list.

Front passenger seat:

Weight categories	Front passenger front airbag enabled	Front passenger front airbag disabled ¹
Category 0: up to 10 kg	X	U, L
Category 0+: up to 13 kg	X	U, L
Category I: 9 to 18 kg	UF, L	U, L
Category II: 15 to 25 kg	UF, L	U, L

Weight categories	Front passenger front airbag enabled	Front passenger front airbag disabled ¹
Category III: 22 to 36 kg	U, L	U, L

¹ The vehicle is equipped with an automatic front passenger front airbag deactivation system. The PASSENGER AIR BAG OFF indicator lamp must be lit.

Rear seats without a belt airbag:

Weight categories	Left, right	Centre ¹
Category 0: up to 10 kg	U, L	U, L
Category 0+: up to 13 kg	U, L	U, L
Category I: 9 to 18 kg	U, L	U, L
Category II: 15 to 25 kg	U, L	U
Category III: 22 to 36 kg	U, L	U

¹ Child restraint systems with a supporting bracket are not suitable for this seat.

Rear seats with a belt airbag:

Weight categories	Left, right
Category 0: up to 10 kg	X
Category 0+: up to 13 kg	X
Category I: 9 to 18 kg	X
Category II: 15 to 25 kg	L ¹
Category III: 22 to 36 kg	L ¹

¹ Only use the approved child seats KIDFIX or KIDFIX XP.

Vehicles with belt airbags: when securing a child in a child restraint system on an outer rear seat, it is essential to observe the following instructions:

- Only use a child restraint system approved by Mercedes-Benz.
- Observe the notes in "Overview of recommended child restraint systems" (→ page 61).

- Secure a rearward-facing child restraint system with the ISOFIX or the i-Size child seat securing system.
- Secure a forward-facing child restraint system with the ISOFIX or the i-Size child seat securing system and, if present, the Top Tether anchorage.

Notes on the suitability of seats for attaching ISOFIX child restraint systems

Observe the following information:

- **When using a baby car seat of category 0/0+ and a rearward-facing child restraint system of category I on a rear seat:** adjust the driver's and front passenger seat such that the seat does not touch the child restraint system.

- **When using a forward-facing child restraint system of category I:** remove the head restraint from the respective seat if possible and position the seat backrest of the child restraint system as flat as possible against the seat backrest of the vehicle seat.
- When you remove the child restraint system you must install the head restraint again immediately and adjust all of the head restraints correctly.
- For certain child restraint systems in weight categories II or III, there might be restrictions in the maximum size setting, e.g. due to possible contact with the roof.
- Make sure that the child's feet do not touch the front seat. If necessary, move the front seat forward slightly.
- The child restraint system must not touch the roof or be put under strain by the head restraints. Adjust the head restraints accordingly.
- Observe the manufacturer's installation instructions for the child restraint system.

Legend for the table:

X	Not suitable for an ISOFIX child restraint system in this weight category and/or size category.
IUF	Suitable for forward-facing ISOFIX child restraint systems of the "Universal" category in this weight category.
IL	Suitable for ISOFIX child restraint systems according to the table in "Overview of the recommended child restraint systems", or if the vehicle and the seat are listed in the child restraint system manufacturer's vehicle model list.

Weight categories	Size category	Equipment	Rear seat Left, right
Carry cot	F	ISO/L1	X
	G	ISO/L2	X
Category 0: up to 10 kg and approx. 6 months	E	ISO/R1	IL

Weight categories	Size category	Equipment	Rear seat Left, right
Category 0+: up to 13 kg and approx. 15 months	E	ISO/R1	IL
	D	ISO/R2	IL
	C	ISO/R3	IL ¹
Category I: 9 to 18 kg and between approx. 9 months and 4 years	D	ISO/R2	IL
	C	ISO/R3	IL ¹
	B	ISO/F2	IUF
	B1	ISO/F2X	IUF
	A	ISO/F3	IUF

¹ When using a child restraint system of size category C (ISO/R3), move the front seat to the highest position. Make sure that the seat backrest of the front seat does not rest against the child restraint system.

Notes on the suitability of seats for attaching i-Size child restraint systems

Observe the following information:

- **When using a rearward-facing child restraint system:** adjust the front seat so that it does not touch the child restraint system.
- **When using a forward-facing child restraint system:** remove the head restraint from the respective seat, if possible. In addition, the seat backrest of the child restraint system must, as far as possible, lie flat against the backrest of the vehicle seat.
- When you remove the child restraint system you must install the head restraint again immediately and adjust all the head restraints correctly.
- Make sure that the child's feet do not touch the front seat. If necessary, move the front seat forward slightly.

- Observe the manufacturer's installation instructions for the child restraint system.

Legend for the table:

X	Not suitable for an i-Size child restraint system in the "Universal" category.
i-U	Suitable for forward-facing and rearward-facing i-Size child restraint systems in the "Universal" category.

	Front passenger seat	Left rear seat	Centre rear seat	Right rear seat
i-Size child restraint system	X	i-U	X	i-U

Overview of recommended child restraint systems

Vehicles with belt airbags: When securing a child in a child restraint system on an outer rear seat, it is essential to observe the following instructions:

- Only use a child restraint system approved by Mercedes-Benz.

- Weight category 0, 0+ or 1: the child restraint system must be installed on the ISOFIX or i-Size child seat securing system.
- Weight category II/III: only used the approved child seats KIDFIX or KIDFIX XP.
- Secure a rearward-facing child restraint system with the ISOFIX or the i-Size child seat securing system.

- Secure a forward-facing child restraint system with the ISOFIX or the i-Size child seat securing system and, if present, the Top Tether anchorage.
- Observe the notes in "Belt airbag in rear seat belt" (→ page 36).

Recommended child restraint systems for attaching with the vehicle seat belt

Weight categories	Manufacturer	Type	Approval number (E1 ...)	Order number (A 000 ...) colour code 9H95
Category 0: up to 10 kg up to approximately 6 months	Britax Römer	BABY SAFE plus II	04 301 146	970 36 00 970 57 00
Category 0+: up to 13 kg up to approximately 15 months	Britax Römer	BABY SAFE plus II	04 301 146	970 36 00 970 57 00
Category I: 9 to 18 kg between approximately 9 months and 4 years	Britax Römer	DUO plus	04 301 133	970 37 00 970 58 00
Category II/III: 15 to 36 kg between approximately 4 and 12 years	Britax Römer	KIDFIX	04 301 198	970 38 00 970 59 00
	Britax Römer	KIDFIX XP	04 301 304	970 61 00

Recommended "Universal" and "Semi-Universal" category ISOFIX child restraint systems

Weight categories	Size category	Manufacturer	Type	Approval number (E1 ...)	Order number (colour code: 9H95)
Category 0+: up to 13 kg up to approximately 15 months	E	Britax Römer	BABY SAFE plus	04 301 146	B6 6 86 8224
Category I: 9 to 18 kg	B1	Britax Römer	DUO plus	04 301 133	A 000 970 37 00 A 000 970 58 00

-  You can obtain further information on the correct child restraint system at any Mercedes-Benz Service Centre.

Child safety locks

Activating/deactivating the child safety lock for the rear doors

 **WARNING** Risk of accident and injury due to children left unattended in the vehicle

If you leave children unattended in the vehicle, they may be able to set the vehicle in motion, for example by:

- Releasing the parking brake.

- Shifting the automatic transmission out of park position **P** or shifting the manual transmission into neutral.
- Starting the engine.

In addition, they may operate vehicle equipment.

- ▶ Never leave children and animals unattended in the vehicle.
- ▶ When leaving the vehicle, always take the key with you and lock the vehicle. This also applies to mobile phones if the "Digital Car Key in the smartphone" function is activated via the Mercedes connect me web app.

⚠ WARNING This poses an increased risk of death due to heat stroke or exposure to cold in the vehicle

If persons – particularly children – experience prolonged exposure to extremely high or low temperatures, this poses a risk of injury or even fatal injury.

- ▶ Never leave anyone – particularly children – unattended in the vehicle.

⚠ WARNING Risk of accident and injury due to children left unattended in the vehicle

If children are travelling in the vehicle, they could:

- Open doors, thereby endangering other persons or road users.
 - Get out of the vehicle and be hit by oncoming traffic.
 - Operate vehicle equipment and become trapped, for example.
- ▶ Always activate the child safety locks installed if children are travelling in the vehicle.
 - ▶ Never leave children unattended in the vehicle.
 - ▶ When leaving the vehicle, always take the key with you and lock the vehicle. This also applies to mobile phones if the

"Digital Car Key in the smartphone" function is activated via the Mercedes connect me web app.

Child safety locks for the rear doors and an override feature for the rear side windows are available.

The child safety lock on the rear doors secures each door separately. The doors can no longer be opened from the inside.

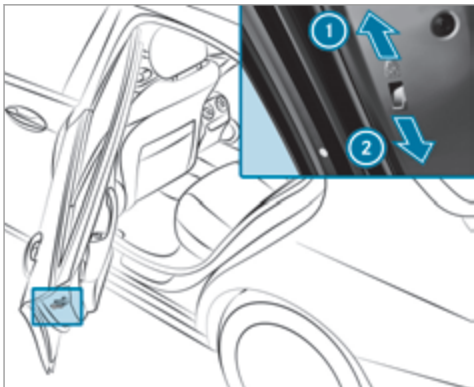

- ▶ Press the lever in direction ① (activate) or ② (deactivate).
- ▶ Make sure that the child safety locks are working properly.

Activating/deactivating the override feature for the rear side windows

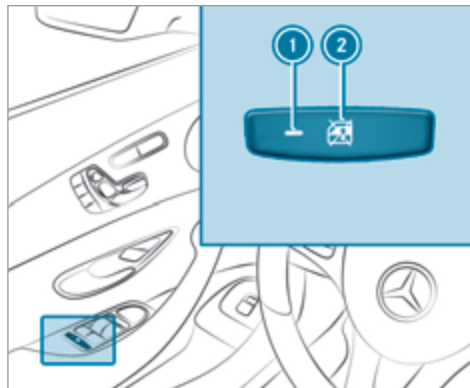

- ▶ **To activate/deactivate:** press button ②.

Opening/closing the side window in the rear is possible:

- With indicator lamp ① lit: via the switch on the driver's door.

- With indicator lamp ① off: via the switch on the corresponding rear door or driver's door.

Notes on pets in the vehicle

⚠ WARNING Risk of accident and injury due to animals left unsecured or unattended in the vehicle

If you leave animals in the vehicle unattended or unsecured, they could possibly press down buttons or switches.

Thereby an animal may:

- activate vehicle equipment and become trapped, for example
- switch systems on or off and endanger other road users

Unsecured animals may be thrown around in the vehicle in the event of an accident or sudden steering and braking manoeuvres and injure vehicle occupants in the process.

- ▶ Never leave animals in the vehicle unattended.
- ▶ Always correctly secure animals while driving, e.g. using a suitable animal carrier.

Key

Overview of key functions

⚠ WARNING Risk of accident and injury due to children left unattended in the vehicle

If children are left unattended in the vehicle, they could:

- open doors, thereby endangering other persons or road users.
- get out of the vehicle and be hit by oncoming traffic.
- operate vehicle equipment and become trapped, for example.

In addition, children could also set the vehicle in motion, for example, by:

- releasing the parking brake.
- shifting the automatic transmission out of park position **P** or shifting manual transmission into neutral.
- starting the engine.

- ▶ When leaving the vehicle, always take the key with you and lock the vehicle.
- ▶ Never leave children and animals unattended in the vehicle.
- ▶ Keep the vehicle key out of reach of children.

! NOTE Damage to the key caused by magnetic fields

- ▶ Keep the key away from strong magnetic fields.



- ① Locks
- ② Battery check lamp
- ③ Unlocks
- ④ Opens/closes the boot lid

The key locks and unlocks the following components:



- The doors
- The boot lid
- The fuel filler flap

If you do not open the vehicle within approximately 40 seconds after unlocking:

- The vehicle is locked again

- Anti-theft protection is reactivated

Do not keep the key together with electronic devices or metal objects. This can affect the key's functionality.

- ❗ If battery check lamp ❷ does not light up after pressing the  or  button, the battery is discharged.

Changing the key battery (→ page 69).

Activating/deactivating the acoustic locking verification signal

Multimedia system:

↳ Vehicle ▶ Vehicle settings ▶ Acoustic lock feedback

- ▶ Activate or deactivate the function.

Activating/deactivating the panic alarm

Requirements:

- ❗ The panic alarm function is only available in certain countries.
- The ignition is switched off.





- ▶ **To activate:** press button ❶ for approximately one second. A visual and audible alarm is triggered.
- ▶ **To deactivate:** briefly press button ❶ again.
- or
- ▶ Press the start/stop button on the cockpit (the key is inside the vehicle).

Changing the unlocking settings

Possible unlocking functions of the key:

- Central unlocking
- Unlocking the driver's door and fuel filler flap

- ▶ **To switch between settings:** press the  and  buttons simultaneously for approximately six seconds until the battery check lamp flashes twice.

If the unlocking function for the driver's door and fuel filler flap has been selected:

- Pressing the  button a second time centrally unlocks the vehicle.
- **Vehicles with KEYLESS-GO:** if you touch the inner surface of the door handle on the driver's door, only the driver's door and fuel filler flap are unlocked.

Reducing the energy consumption of the key

All vehicles: if you do not use the vehicle or a key for an extended period of time, you can reduce the energy consumption of the respective key. To do so, deactivate the key functions.

- ▶ **To deactivate:** press the  button on the key twice in rapid succession. The battery check lamp of the key flashes twice briefly and lights up once.
- ▶ **To activate:** press any button on the key.

- ⓘ When the vehicle is started with the key in the stowage compartment of the centre console, the key functions are automatically activated (→ page 162).

Removing/inserting the emergency key

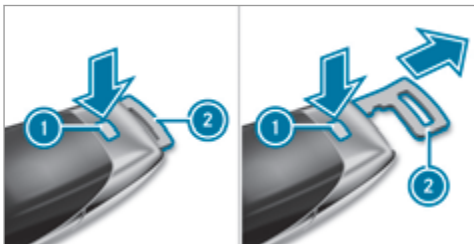

- ▶ **To remove:** press release knob ①. Emergency key ② is pushed out slightly.
 - ▶ Pull out emergency key ② until it engages in the intermediate position.
- ⓘ You can use the intermediate position of emergency key ② to attach the key to a key ring.

- ▶ Press release knob ① again and fully remove emergency key ②.
- ▶ **To insert:** press release knob ①.
- ▶ Insert emergency key ② to the intermediate position or fully until it engages.

Replacing the key battery

⚠ DANGER Serious damage to health caused by swallowing batteries

Batteries contain toxic and corrosive substances. Swallowing batteries may cause serious damage to health.

There is a risk of fatal injury.

- ▶ Keep batteries out of the reach of children.
- ▶ If batteries are swallowed, seek medical attention immediately.

🍃 ENVIRONMENTAL NOTE Environmental damage due to improper disposal of batteries



Batteries contain pollutants. It is illegal to dispose of them with the household rubbish.



Dispose of batteries in an environmentally responsible manner. Take discharged batteries to a qualified specialist workshop or to a collection point for used batteries.

Requirements:

- You require a CR 2032 3 V cell battery.

Mercedes-Benz recommends that you have the battery replaced at a qualified specialist workshop.

- ▶ Remove the emergency key (→ page 69).

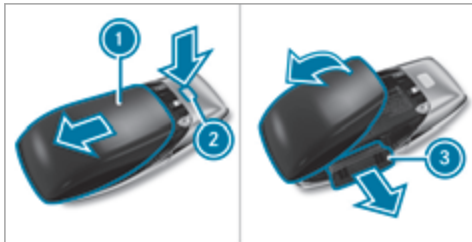

- ▶ Press release button (2) down fully and slide cover (1) in the direction of the arrow.
- ▶ Fold out cover (1) in the direction of the arrow and remove.
- ▶ Remove battery compartment (3) and take out the discharged battery.
- ▶ Insert the new battery into battery compartment (3). Observe the positive pole marking in the battery compartment and on the battery.

- ▶ Push in battery compartment (3).
- ▶ Re-attach cover (1) and push it until it engages.

Problems with the key

Problem	Possible causes/consequences and ▶ Solutions
<p>You can no longer lock or unlock the vehicle.</p>	<p>Possible causes:</p> <ul style="list-style-type: none"> • The key battery is discharged or nearly discharged. • There is interference from a powerful radio signal source. • The key is faulty. <ul style="list-style-type: none"> ▶ Check the battery using the battery check lamp and replace if necessary . ▶ Use the emergency key to lock or unlock .

Problem	Possible causes/consequences and ► Solutions
	<ul style="list-style-type: none"> ► Have the key checked at a qualified specialist workshop.
You have lost a key.	<ul style="list-style-type: none"> ► Have the key deactivated at a qualified specialist workshop. ► If necessary, have the locks changed as well.

Doors

Notes on the additional door lock

The additional door lock is only available for vehicles for the United Kingdom.

⚠ WARNING Risk of injury to persons inside the vehicle when the additional door lock is activated

If the additional door lock is activated, the doors can no longer be opened from the inside.

If there are persons in the vehicle, they can no longer leave the vehicle, e.g. in hazardous situations.

- Never leave persons unattended in the vehicle, particularly children, elderly persons or persons in need of help.
- If there are persons in the vehicle, do not activate the additional door lock.

The additional door lock is automatically activated:

- After locking the vehicle with the key.
- After locking the vehicle using KEYLESS-GO.
- ⓘ After locking the vehicle, the horn can be operated for a short time.
- ⓘ After locking the vehicle, pressing the button to centrally unlock the vehicle from inside will trigger an alarm (→ page 72).

If the additional door lock is activated, the doors cannot be opened from the inside.

You can deactivate the additional door lock by deactivating the interior protection (→ page 93).

Unlocking/opening the doors from the inside

- **United Kingdom only:** observe the notes on the additional door lock (→ page 71).



- ▶ Pull door handle ②.
Locking pin ① pops up when the door is unlocked.

Centrally locking and unlocking the vehicle from the inside

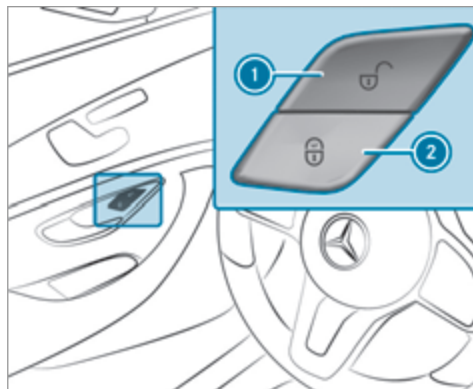

- ▶ **To unlock:** press button ①.
- ▶ **To lock:** press button ②.

This does not lock or unlock the fuel filler flap.
The vehicle is not unlocked:

- If you have locked the vehicle using the key.

- If you have locked the vehicle using KEY-LESS-GO.

Locking and unlocking the vehicle with the mobile phone (NFC)

Requirements:

- The vehicle is equipped with the "digital vehicle key" function.
 - The "digital vehicle key" function is activated via the Mercedes me connect web app: <http://www.mercedes.me>.
 - A suitable mobile phone with NFC aerial (Near Field Communication) and Secure Element.
 - **A sufficient charge status on the mobile phone.** On some mobile phones, the function is also available when the battery is discharged.
- ⓘ You can check the suitability of your mobile phone by entering the phone number at <http://www.mercedes.me>.

Information about suitable mobile phones can be obtained from your Mercedes-Benz service centre or at <http://www.mercedes-benz.com/connect>.

- ❶ Protective cases around the mobile phone can impair the functionality.
- ❶ You can also lock or unlock the vehicle with a digital vehicle key sticker. Further information can be obtained at your Mercedes-Benz Service Centre or via <http://www.mercedes-benz.com/connect>.
- ❶ The function is only available in combination with Mercedes me connect and only in certain countries.

If the vehicle has been parked for longer than two weeks, the NFC aerial in the door handle is deactivated.

- ▶ Pull door handle.
The NFC aerial is activated.

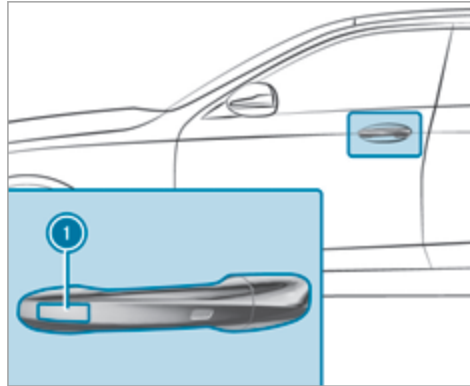

- ▶ Touch the door handle on the driver's door in the area where NFC aerial ❶ is located with the part of the mobile phone where the NFC aerial is located.
The vehicle is locked or unlocked alternately.

If you lose your mobile phone, deactivate the "digital vehicle key" service in Mercedes me connect via <http://www.mercedes.me>.

- ❶ Mercedes-Benz recommends that you carry the emergency key in case of function restrictions.

Locking/unlocking the vehicle with KEY-LESS-GO

Requirements:

- The key is outside the vehicle.
- The distance between the key and the vehicle does not exceed 1 m.
- The driver's door and the door at which the door handle is used are closed.

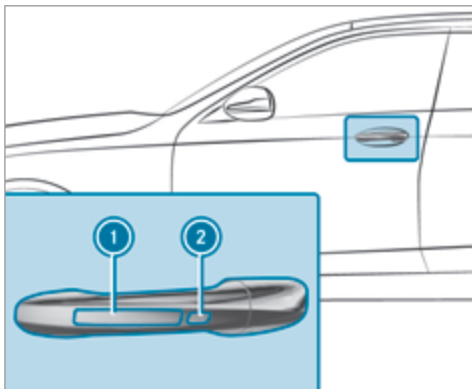

▶ **To unlock the vehicle:** touch the inner surface of the door handle.

▶ **To lock the vehicle:** touch sensor surface ① or ②.

▶ **Convenience closing:** touch recessed sensor surface ② for an extended period.

ⓘ Further information on convenience closing (→ page 85).

If you open the boot lid from outside it is automatically unlocked.

Problems with KEYLESS-GO

Problem	Possible causes/consequences and ▶ Solutions
<p>You can no longer lock or unlock the vehicle using KEYLESS-GO.</p>	<p>Possible causes:</p> <ul style="list-style-type: none"> • KEYLESS-GO has been deactivated . • The key battery is discharged or nearly discharged. • There is interference from a powerful radio signal source.

Problem	Possible causes/consequences and ► Solutions
	<ul style="list-style-type: none"> • The key is faulty. ► Activate KEYLESS-GO . ► Check the battery using the battery check lamp and replace if necessary . ► Use the emergency key to lock or unlock the vehicle . ► Have the vehicle and key checked at a qualified specialist workshop.

Activating/deactivating the automatic locking feature

The vehicle is locked automatically when the ignition is switched on and the wheels are turning faster than walking pace.

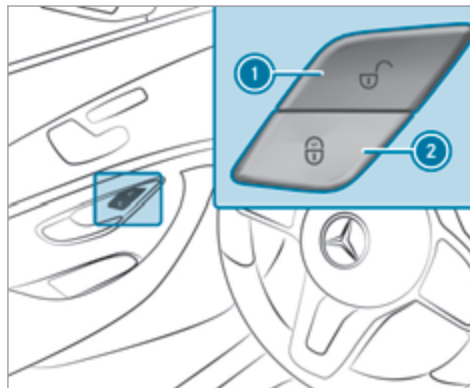

- **To activate:** press and hold button ② for approximately five seconds until an acoustic signal sounds.
- **To deactivate:** press and hold button ① for approximately five seconds until an acoustic signal sounds.

There is a danger of being locked out if the function is activated:

- While the vehicle is being tow started/ pushed.
- On a roller dynamometer.

Locking/unlocking the driver's door with the emergency key element

i If you wish to lock the vehicle entirely using the emergency key element, first press the button for locking from the inside while the driver's door is open. Then proceed to lock the driver's door using the emergency key element.

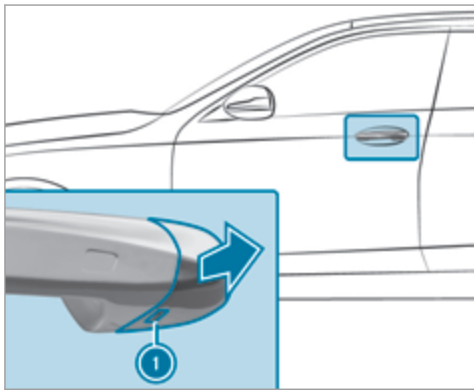

- ▶ Insert the emergency key as far as it will go into opening **1** in the cover.
- ▶ Pull and hold the door handle.
- ▶ Pull the cover on the emergency key as straight as possible away from the vehicle until it releases.
- ▶ Release the door handle.

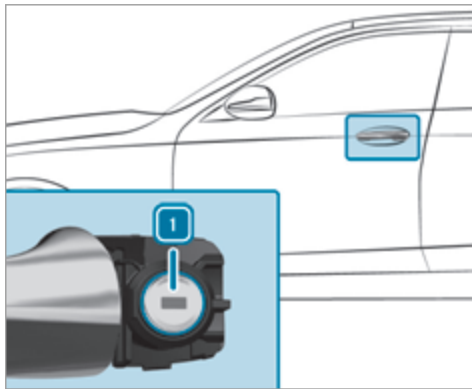

- ▶ **To unlock:** turn the emergency key anti-clockwise to position **1**.
- ▶ **To lock:** turn the emergency key clockwise to position **1**.
- i** **Right-hand drive vehicles:** turn the emergency key in the opposite direction in each case.
- ▶ Carefully press the cover onto the lock cylinder until it engages and is seated firmly.

Boot

Opening the boot lid

⚠ WARNING Risk of exhaust gas poisoning

Combustion engines emit poisonous exhaust gases such as carbon monoxide. Exhaust gases can enter the vehicle interior if the boot lid is open when the engine is running, especially if the vehicle is in motion.

- ▶ Always switch off the engine before opening the boot lid.
- ▶ Never drive with the boot lid open.

! **NOTE** Damage to the boot lid by obstacles above the vehicle

The boot lid swings upwards when it is opened.

► Therefore, make sure that there is sufficient clearance above the boot lid.

You have the following options to open the boot lid:

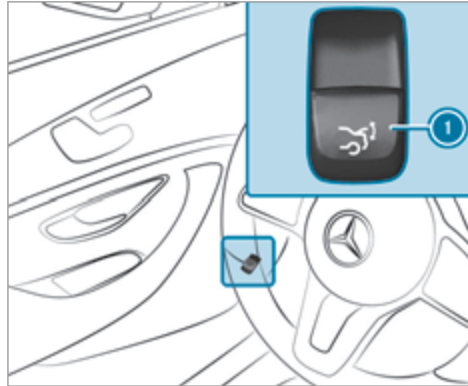

- ▶ Pull boot lid remote operating switch ①.
- ▶ Press and hold the  button on the key.
- ▶ Pull the boot lid handle.
- ▶ **Vehicles with HANDS-FREE ACCESS:** use your foot to kick below the bumper (→ page 79).
- ▶ **Vehicles with boot lid convenience closing feature:** with the boot lid stopped in an

intermediate position, pull it upwards and release as soon as it begins to open. With the boot lid opening limiter switched on, manually pull the stopped boot lid upwards.

Vehicles with boot lid convenience closing: if an object restricts the boot lid during the automatic opening process, the obstacle detection stops the boot lid. The obstacle detection function is only an aid and is not a substitute for your attentiveness.

Closing the boot lid

! **WARNING** Risk of injury from unsecured items in the vehicle

If objects, luggage or loads are not secured or not secured sufficiently, they could slip, tip over or be thrown around and thereby hit vehicle occupants.

There is a risk of injury, particularly in the event of sudden braking or a sudden change in direction.

- ▶ Always stow objects in such a way that they cannot be thrown around.
- ▶ Before the journey, secure objects, luggage or loads against slipping or tipping over.

⚠ WARNING Risk of becoming trapped during automatic closing of the boot lid

Parts of the body could become trapped during automatic closing of the boot lid. Moreover, people, e.g. children, may be standing in the closing area or may enter the closing area during the closing process.

- ▶ Make sure that nobody is in the vicinity of the closing area during the closing process.
- ▶ Use one of the following options to stop the closing process:
 - Press the  button on the key.
 - Press or pull the remote operating switch on the driver's door.
 - Press the closing or locking button on the boot lid.

- Pull the boot lid handle.

Vehicles with HANDS-FREE ACCESS: it is also possible to stop the closing process by moving your foot in a kicking motion under the rear bumper.

You have the following options to close the boot lid:

- ▶ Pull the boot lid down using the handle recess and push it closed.
- ▶ **Vehicles with HANDS-FREE ACCESS:** with the boot lid completely opened, kick your foot below the bumper (→ page 79).
- ▶ **Vehicles with boot lid convenience closing:** pull the boot lid handle.
- ▶ **Vehicles with boot lid convenience closing and KEYLESS-GO:** with the boot lid completely opened, press and hold the  button on the key (with the key in the vicinity of the vehicle).

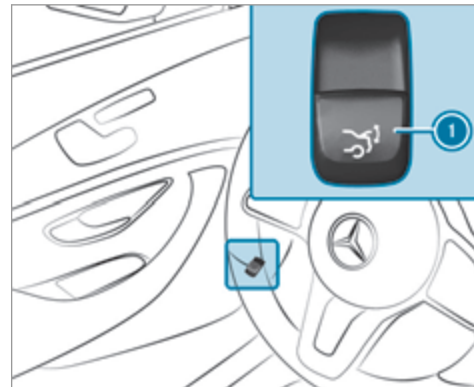

- ▶ **Vehicles with boot lid convenience closing:** press boot lid remote operating switch  1.

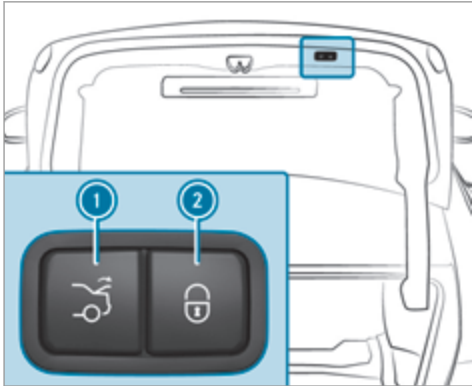

- ▶ **Vehicles with boot lid convenience closing:** press closing button ① in the boot lid.
- ▶ **Vehicles with boot lid convenience closing and KEYLESS-GO:** press locking button ② in the boot lid.
If a key is detected outside the vehicle, the boot lid closes and the vehicle is locked.

Automatic reversing function of the boot lid

If an object restricts the boot lid during the automatic closing process, the boot lid opens again automatically. The automatic reversing function is only an aid and is not a substitute for your attentiveness.

- ▶ When closing, make sure that no body parts are in the closing area.

⚠ WARNING Risk of becoming trapped despite reversing function

The reversing function does not react:

- to soft, light and thin objects, e.g. fingers.
- over the last 8 mm of the closing path.

In these situations in particular, the reversing function cannot prevent someone being trapped.

- ▶ When closing, make sure that no body parts are in the closing area.
- ▶ If someone is trapped, use one of the following options:
 - Press the  button on the key.

- Press the remote operating switch on the driver's door.
- Press the closing or locking button on the boot lid.
- Pull the boot lid handle.

HANDS-FREE ACCESS function

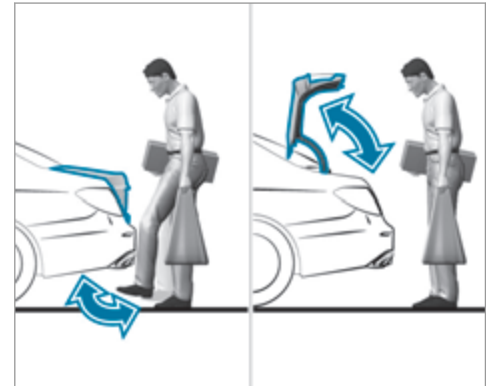

With HANDS-FREE ACCESS you can open, close or interrupt boot lid movement by performing a kicking movement under the rear bumper.

The kicking movement triggers the opening or closing process alternately.

Observe the notes when opening (→ page 76) and closing (→ page 77) the boot lid.

i A warning tone sounds while the boot lid is opening or closing.

⚠ WARNING Risk of burns caused by a hot exhaust system

The vehicle exhaust system can become very hot. If you use HANDS-FREE ACCESS, you could burn yourself by touching the exhaust system.

▶ Always ensure that you only make a kicking movement within the detection range of the sensors.

! **NOTE** Damage to the vehicle caused by unintentionally opening the boot lid:

- when using an automatic car wash
 - when using a high pressure cleaner
- ▶ Deactivate KEYLESS-GO or make sure that the key located is at least 3 m away from the vehicle in such situations.

When making the kicking movement, make sure that your feet are firmly on the ground, otherwise you could lose your balance, e.g. on ice.

Requirements:

- The key is behind the vehicle.
- Stand at least 30 cm away from the vehicle while performing the kicking movement.
- Do not come into contact with the bumper while making the kicking movement.
- Do not carry out the kicking movement too slowly.
- The kicking movement must be towards the vehicle and back.

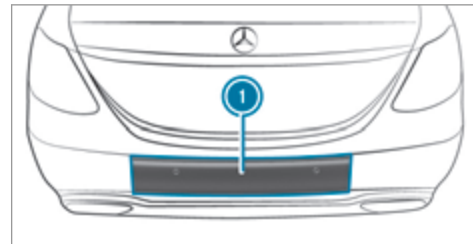

1 Sensor detection range

If several consecutive kicking movements are not successful, wait ten seconds.

System limitations

The system may be impaired or may not function if:

- Snow or dirt, e.g. from road salt, covers the sensor area.
- The kicking movement is made using a prosthetic leg.

The boot lid could be opened or closed unintentionally, in the following situations:

- If a person's arms or legs are moving in the sensor detection range, e.g. when polishing the vehicle, sitting on the edge of the boot, or picking up objects.
- If objects are moved or placed behind the vehicle, e.g. charging cables, tensioning straps or luggage.
- When working on the trailer coupling, trailers or rear bicycle racks.

Deactivate KEYLESS-GO (→ page 68) or do not carry the key about your person in such situations.

Switching separate boot locking on or off

If you centrally unlock the vehicle while separate locking is activated, the boot remains locked.

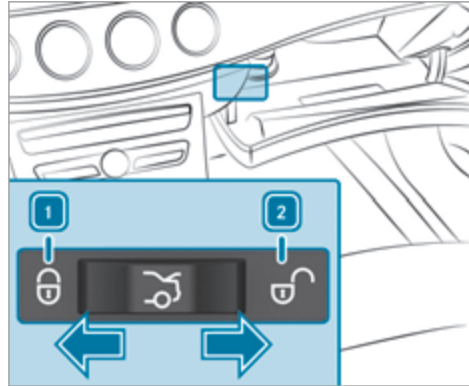

- ▶ **To switch on:** slide the switch to position **1**.
- ▶ **To switch off:** slide the switch to position **2**.
- i** If an accident has been detected, the boot unlocks even if separate locking is switched on.

Activating/deactivating the boot lid opening limiter

Multimedia system:

➔ [Vehicle](#) ▶ [Vehicle settings](#) ▶ [Boot opening-height restriction](#)

Activating the function allows you to avoid bumping the boot lid on a low garage ceiling, for example.

- ▶ Activate or deactivate the function.

Roller sunblinds

Extending the rear side window roller sunblinds

! **NOTE** Damage to the inertia reel due to it snapping back

If suddenly snapped back, the inertia reel may be damaged.

- ▶ Always move the roller sun blind manually.

- ▶ Do not drive with the roller sun blind hooked in and one or more side windows open at the same time.

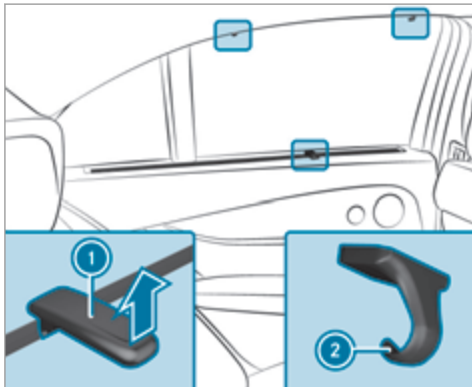

- ▶ Pull the roller sun blind out by tab ① and hook it onto brackets ② at the top of the window.

Extending/retracting the rear window roller sunblind

⚠ WARNING Risk of entrapment when extending or retracting the roller sunblind

Body parts could become entrapped in the sweep of the roller sunblind when it is being extended or retracted.

- ▶ Make sure that no body parts are in the sweep of the roller sunblind when it is being extended or retracted.
- ▶ If someone becomes trapped, briefly press the button again. The opening or closing process is briefly stopped. The roller sun blind then returns to its starting position.

! NOTE Damage caused by objects

- ▶ Make sure that the roller sunblind can move freely.

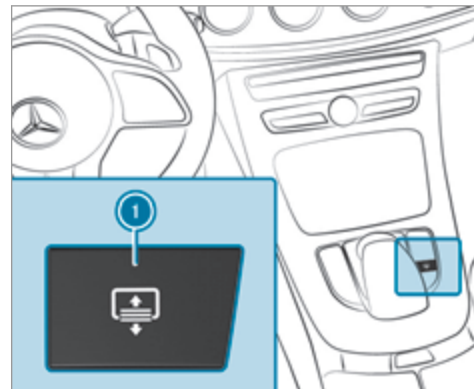

- ▶ To extend or retract: press button ①.

Side windows

Opening and closing the side windows

⚠ WARNING Risk of becoming trapped when opening a side window

When you open a side window, parts of the body could be drawn in or become trapped between the side window and window frame.

- ▶ When opening, make sure that nobody is touching the side window.
- ▶ If someone is trapped, release the button immediately or pull it in order to close the side window again.

⚠ WARNING Risk of becoming trapped when closing a side window

When closing a side window, body parts could be trapped in the closing area in the process.

- ▶ When closing, make sure that no body parts are in the closing area.

- ▶ If someone is trapped, release the button immediately or press the button in order to reopen the side window.

⚠ WARNING Risk of becoming trapped when children operate the side windows

Children could become trapped if they operate the side windows, particularly when unattended.

- ▶ Activate the override feature for the rear side windows.
- ▶ When leaving the vehicle, always take the key with you and lock the vehicle.
- ▶ Never leave children unattended in the vehicle.

Requirements:

- The power supply or the ignition is switched on.

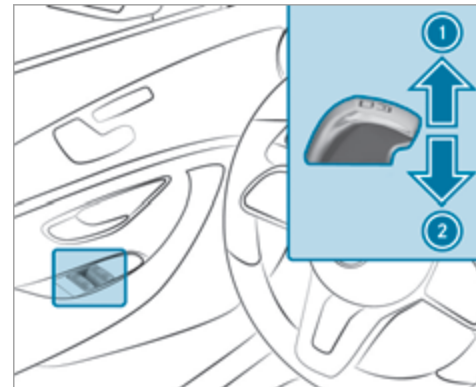

- ① Closing
- ② Opening

The buttons on the driver's door take precedence.

- ▶ **To start automatic operation:** press the  button beyond the point of resistance or pull and release it.

▶ **To interrupt automatic operation:** press or pull the  button again.

When the vehicle is switched off, the side windows can continue being operated.

The function is available for around five minutes or until a front door is opened.

Automatic reverse function of the side windows

If an object blocks a side window during the closing process, the side window opens again automatically. The automatic reverse function is only an aid and is not a substitute for your attentiveness.

▶ When closing, make sure that no body parts are in the closing area.

⚠ WARNING Risk of becoming trapped despite there being reversing protection on the side window

The reverse function does not react:

- to soft, light and thin objects, e.g. small fingers

- during resetting

This means that the reverse function cannot prevent someone from becoming trapped in these situations.

- ▶ When closing, make sure that no body parts are in the closing area.
- ▶ If someone becomes trapped, press the  button to open the side window again.

Convenience opening (ventilating the vehicle before starting a journey)

⚠ WARNING Risk of entrapment when opening a side window

When opening a side window, parts of the body could be drawn in or become trapped between the side window and window frame.

- ▶ When opening, make sure that nobody is touching the side window.
- ▶ Release the button immediately if somebody becomes trapped.

▶ Press and hold the  button on the key. The following functions are performed:

- The vehicle is unlocked.
- The side windows are opened.
- The sliding sunroof is opened.
- The panoramic sliding sunroof is opened.
- The seat ventilation of the driver's seat is switched on.

If the roller sunblinds of the panoramic sliding sunroof are closed, the roller sunblinds are opened first.

▶ **To continue convenience opening:** press the  button again.

▶ **To interrupt convenience opening:** release the  button.

Convenience closing (closing the vehicle from outside)

⚠ WARNING Risk of entrapment caused by inadvertent convenience closing

When the convenience closing feature is operating, parts of the body could become trapped in the closing area of the side window and the sliding sunroof.

- ▶ Observe the complete closing procedure when using convenience closing.

- ▶ When closing, make sure that no body parts are in the closing area.

- ▶ Press and hold the  button on the key. The following functions are performed:
 - The vehicle is locked.
 - The side windows are closed.
 - The sliding sunroof is closed.
 - The panoramic sliding sunroof is closed.

- ▶ **To close the roller sunblinds:** press the  button again.

- ▶ **To interrupt convenience closing:** release the  button.

- ⓘ Convenience closing can also be operated with KEYLESS-GO (→ page 73).

Problems with the side windows

Problem

A side window cannot be closed and you cannot see the cause.

Possible causes/consequences and ▶ Solutions

- ▶ Check to see if any objects are in the window guide.

⚠ WARNING Risk of becoming trapped or fatally injured if reversing protection is not activated

If you close a side window again immediately after it has been blocked or reset, the side window closes with increased or maximum force. The reversing feature is then not active.

Parts of the body could become trapped in the closing area in the process.

Problem	Possible causes/consequences and ► Solutions
	<ul style="list-style-type: none"> ► Make sure that no parts of the body are in the closing area. ► To stop the closing process, release the button or press the button again to reopen the side window. <p>If a side window is obstructed during closing and reopens again slightly:</p> <ul style="list-style-type: none"> ► Immediately after the window blocks, pull the corresponding button again until the side window has closed, and hold the button for an additional second. The side window is closed with increased force. <p>If a side window is obstructed again during closing and reopens again slightly:</p> <ul style="list-style-type: none"> ► Repeat the previous step. The side window is closed without the automatic reversing function.
The side windows cannot be opened or closed using the convenience opening feature.	<p>The key battery is discharged or nearly discharged.</p> <ul style="list-style-type: none"> ► Check the battery using the battery check lamp and replace if necessary .

Sliding sunroof

Opening and closing the sliding sunroof

-  The term "sliding sunroof" also refers to the panoramic sliding sunroof.

⚠ WARNING Risk of becoming trapped while opening and closing the sliding sunroof

During opening and closing, parts of the body could get caught in the sweep of the sliding sunroof.

- ▶ When opening or closing, make sure that no body parts are in the sweep.
- ▶ Release the button immediately if somebody becomes trapped.

or

- ▶ Press the button in any direction during the automatic opening/closing process. The opening/closing process is stopped.

⚠ WARNING Risk of entrapment if the sliding sunroof is operated by children

Children operating the sliding sunroof could get caught in the moving parts, particularly if unattended.

- ▶ Never leave children unattended in the vehicle.
- ▶ When leaving the vehicle, always take the key with you and lock the vehicle.

⚠ WARNING Risk of entrapment while opening and closing the roller sunblinds

When opening or closing, make sure that no body parts become trapped between the roller sunblind and frame or sliding sunroof.

- ▶ When opening or closing, make sure that no body parts are in the sweep of the roller sunblind.
- ▶ Release the switch immediately if somebody becomes trapped.

or

- ▶ Press the switch in any direction during the automatic opening/closing process. The opening/closing process is stopped.

! NOTE Malfunction caused by snow and ice

Snow and ice may lead to a malfunction of the sliding sunroof.

- ▶ Only open the sliding sunroof if it is free of snow and ice.

! NOTE Damage caused by protruding objects

Objects that protrude from the sliding sunroof may damage the sealing strips.

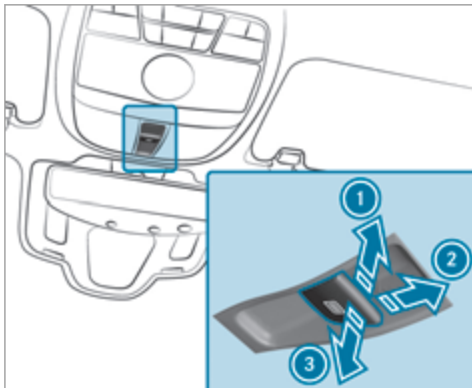

- ▶ Do not allow anything to protrude from the sliding sunroof.



- ① To raise
- ② To open
- ③ To close/lower

Use the  button to operate the panoramic sliding sunroof and the roller sunblind.

- The panoramic sliding sunroof can be opened only when the roller sunblind is open.

- The roller sunblind can be operated only when the panoramic sliding sunroof is closed.
- ▶ **To start automatic operation:** press the  button beyond the point of resistance or pull and release it.
- ▶ **To interrupt automatic operation:** briefly press the  button in any direction. The opening/closing process is stopped.
- Check whether the panoramic sliding sunroof can be raised or opened when a roof rack is fitted.

Automatic reversing function of the sliding sunroof

If there is an object obstructing the sliding sunroof during the closing process, the sliding sunroof opens again automatically. The automatic reverse function is only an aid and is not a substitute for your attentiveness.

- ▶ When closing, make sure that no body parts are in the closing area.

⚠ WARNING Risk of entrapment even with the reversing feature active

The reverse function does not react in particular:

- to soft, light and thin objects, e.g. small fingers
- over the last 4 mm of the closing path
- during resetting

This means that the reverse function cannot prevent someone from becoming trapped in these situations.

- ▶ When closing, make sure that no body parts are in the closing area.
- ▶ Release the button immediately if somebody becomes trapped.

or

- ▶ Briefly press the button in any direction during automatic operation. The closing process is stopped.

Automatic reversing function of the roller sunblind

If there is an object obstructing the roller sunblind during the closing process, the roller sunblind opens again automatically. The automatic reverse function is only an aid and is not a substitute for your attentiveness.

- ▶ When closing the roller sunblind, make sure that no body parts are in the range of movement.

⚠ WARNING Risk of becoming trapped despite reversing function

In particular, the reversing function does not react to soft, light and thin objects, e.g. small fingers.

This means that the reversing function cannot prevent entrapment in these situations.

- ▶ When closing the roller sunblind, make sure that no body parts are in the range of movement.
- ▶ Release the button immediately if somebody becomes trapped.

or

- ▶ Press the button in any direction during the automatic closing process. The closing process is stopped.

Automatic features of the sliding sunroof

- ⓘ The term "sliding sunroof" also refers to the panoramic sliding sunroof.

By pushing or pulling the  button, you can interrupt the automatic functions: "Rain closing function when driving" and "Automatic lowering feature".

Automatic closing when the vehicle is stationary

- if it starts to rain (detection by the rain sensor on the windscreen)
- after six hours
- if there is a malfunction in the power supply

The rear of the sliding sunroof is then raised.

Rain closing function when driving
Vehicles with a panoramic sliding sunroof: If it starts to rain, the raised sliding sunroof is automatically lowered while the vehicle is in motion.

Automatic lowering feature

Vehicles with a panoramic sliding sunroof: If the sliding sunroof is raised at the rear, the sliding sunroof is automatically lowered slightly at higher speeds. At low speeds, it is raised again automatically.

⚠ WARNING Risk of entrapment by automatic lowering of the sliding sunroof

At high speeds the raised sliding sunroof automatically lowers slightly at the rear.

This could trap you or other persons.

- ▶ Make sure that nobody reaches into the sweep of the sliding sunroof whilst the vehicle is in motion.

- ▶ If somebody becomes trapped, briefly push the sliding sunroof button forwards or backwards.
The sliding sunroof lifts during opening.

Problems with the sliding sunroof

- ❗ The term "sliding sunroof" also refers to the panoramic sliding sunroof.

Problem





The sliding sunroof cannot be closed and you cannot see the cause.

Possible causes/consequences and ▶ Solutions

- ⚠ **WARNING** Risk of becoming trapped or fatal injury by closing the sliding sunroof again
If you close the sliding sunroof again immediately after it has been blocked or reset, the sliding sunroof closes with increased force.
Parts of the body could become trapped in the closing area in the process.
 - ▶ Make sure that no parts of the body are in the closing area.
 - ▶ Release the button immediately if somebody becomes trapped.or
 - ▶ Press the button in any direction during the automatic closing process.
The closing process is stopped.

If the sliding sunroof is obstructed during closing and reopens again slightly:

- ▶ Immediately after automatic reversing, pull and hold the  button down again to the point of resistance until the sliding sunroof is closed.
The sliding sunroof is closed with increased force.

Problem	Possible causes/consequences and ► Solutions
	<p>If the sliding sunroof is obstructed again and reopens again slightly:</p> <ul style="list-style-type: none"> ► Repeat the previous step. <p>The sliding sunroof is closed again with increased force.</p>
<p>Vehicles without a panoramic sliding sunroof: The sliding sunroof does not operate smoothly.</p>	<ul style="list-style-type: none"> ► Pull the  button up repeatedly to the point of resistance until the sliding sunroof is fully open. ► Press the  button for another second. ► Close the sliding sunroof.
<p>Vehicles with a panoramic sliding sunroof: The sliding sunroof or the roller sunblind does not operate smoothly.</p>	<ul style="list-style-type: none"> ► Pull and hold the button  little by little until the sliding sunroof is fully closed. ► Pull and hold the button  little by little until the roller sunblind is fully closed. ► Use automatic operation to fully open and then close the sliding sunroof.

Anti-theft protection

Function of the immobiliser

The immobiliser prevents your vehicle from being started without the correct key.

The immobiliser is automatically activated when the ignition is switched off and deactivated when the ignition is switched on.

ATA (Anti-Theft Alarm system)

Function of the ATA system

If the ATA system is primed, a visual and audible alarm is triggered in the following situations:

- When a door is opened
- When the boot lid is opened
- When the bonnet is opened

- When the interior protection is triggered (→ page 93)
- When tow-away protection is triggered (→ page 92)

The ATA system is primed automatically after approximately 10 seconds:

- After locking the vehicle with the key
- After locking the vehicle using KEYLESS-GO

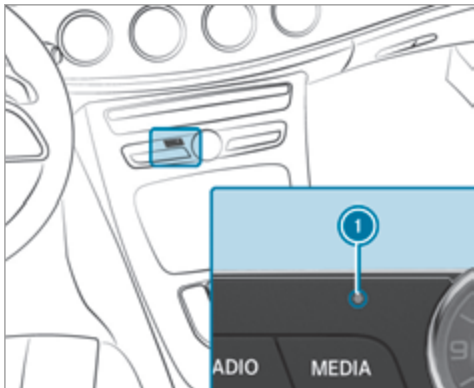

Indicator lamp ① flashes when the ATA system is activated.

The ATA system is automatically deactivated:

- After unlocking the vehicle with the key
- After pressing the start/stop button with the key in the stowage compartment (→ page 162)

- After unlocking the vehicle using KEYLESS-GO

- ① When the Mercedes-Benz emergency call system is active and the alarm stays on for more than 30 seconds, a message is automatically sent to the Customer Assistance Centre (→ page 291).

Deactivating the ATA

- ▶ Press the ,  or  button on the key.

or

- ▶ Press the start/stop button with the key in the stowage compartment (→ page 162)

Deactivating the alarm using KEYLESS-GO:

- ▶ Grasp the outside door handle with the key outside the vehicle.

Function of tow-away protection

An audible and visual alarm is triggered if your vehicle's angle of inclination is altered while tow-away protection is primed.



Tow-away protection is automatically primed after about 60 seconds:

- After locking the vehicle with the key.
- After locking the vehicle using KEYLESS-GO.

Tow-away protection is only primed when the following components are closed:

- The doors
- The boot lid

Tow-away protection is automatically deactivated:

- After pressing the  or  button on the key
- After pressing the start/stop button with the key in the stowage compartment (→ page 162)
- After unlocking the vehicle using KEYLESS-GO
- When using HANDS-FREE ACCESS

Priming/deactivating tow-away protection

Multimedia system:

↳ Vehicle ▶ Vehicle settings ▶ Tow-away protection

▶ Activate or deactivate the function.

Tow-away protection remains deactivated until:

- The vehicle is unlocked again.
- A door is opened.
- The vehicle is locked again.

Function of interior protection

When interior protection is primed, a visual and audible alarm is triggered if movement is detected in the vehicle interior.



Interior protection is primed automatically after approximately 10 seconds:

- After locking the vehicle with the key.
- After locking the vehicle using KEYLESS-GO.

Interior protection is only primed when the following components are closed:

- Doors
- The boot lid

Interior protection is automatically deactivated:

- After pressing the  or  button on the key.
- After pressing the start/stop button with the key in the stowage compartment (→ page 162).
- After unlocking the vehicle using KEYLESS-GO.
- When using HANDS-FREE ACCESS.

The following situations can lead to a false alarm:

- Moving objects such as mascots in the vehicle interior.
- The side window is open.
- When the sliding sunroof is open.
- The panoramic sliding sunroof is open.

Activating/deactivating interior protection

Multimedia system:

↳ Vehicle ▶ Vehicle settings ▶ Interior motion sensor

▶ Activate or deactivate the function.

Interior protection remains deactivated until:

- The vehicle is unlocked again.
- A door is opened.
- The vehicle is locked again.

Notes on the correct driver's seat position

⚠ WARNING Risk of injury through adjusting vehicle settings while the vehicle is in motion

You could lose control of the vehicle in the following situations:

- if you adjust the driver's seat, the head restraints, the steering wheel or the mirror while the vehicle is in motion
- if you fasten your seat belt while the vehicle is in motion

▶ Before starting the engine: adjust the driver's seat, the head restraints, the steering wheel or the mirror and fasten your seat belt.

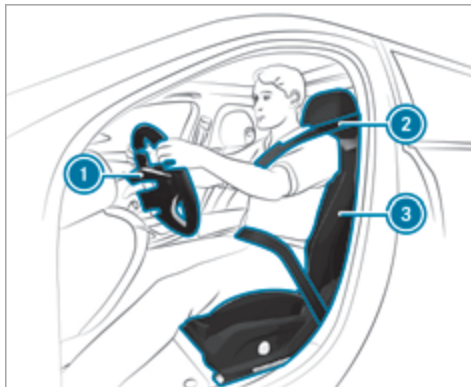

Ensure the following when adjusting the steering wheel ①, seat belt ② and driver's seat ③:

- you are as far away from the driver's airbag as possible
- you are sitting in a normal upright position
- your thighs are slightly supported by the seat cushion

- your legs are not entirely stretched and you can depress the pedals properly
- the back of your head is supported at eye level by the centre of the head restraint
- you can hold the steering wheel with your arms slightly bent
- you can move your legs freely
- you can see all the displays on the instrument cluster clearly
- you have a good overview of the traffic conditions
- the seat belt is pulled snugly against the body and is routed across the centre of your shoulder and across your hips in the pelvic area

Seats

Adjusting the front seat mechanically and electrically (without Seat Comfort Package)

- ⚠ WARNING** Risk of becoming trapped if the seats are adjusted by children

Children could become trapped if they adjust the seats, particularly when unattended.

- ▶ When leaving the vehicle, always take the key with you and lock the vehicle. This also applies to mobile phones if the "Digital Car Key in the smartphone" function is activated via the Mercedes connect me web App.
- ▶ Never leave children unattended in the vehicle.

The seats can be adjusted when the ignition is switched off.

- ⚠ WARNING** Risk of becoming trapped when adjusting the seats

When you adjust a seat, you or other vehicle occupants could become trapped, e.g. on the seat guide rail.

- ▶ Make sure when adjusting a seat that no one has any body parts in the sweep of the seat.

Observe the safety notes on "Airbags" and "Children in the vehicle".

- ⚠ WARNING** Risk of accident due to the driver's seat not being engaged

If the driver's seat is not engaged, it could move unexpectedly while the vehicle is in motion.

This could cause you to lose control of the vehicle.

- ▶ Always make sure that the driver's seat is engaged before starting the vehicle.

- ⚠ WARNING** Risk of injury through adjusting vehicle settings while the vehicle is in motion

You could lose control of the vehicle in the following situations:

- if you adjust the driver's seat, the head restraints, the steering wheel or the mirror while the vehicle is in motion
 - if you fasten your seat belt while the vehicle is in motion
- ▶ Before starting the engine: adjust the driver's seat, the head restraints, the steering wheel or the mirror and fasten your seat belt.

- ⚠ WARNING** Risk of becoming trapped if the seat height is adjusted carelessly

If you adjust the seat height carelessly, you or other vehicle occupants could be trapped and thereby injured.

Children in particular could accidentally press the electrical seat adjustment buttons and become trapped.

- ▶ While moving the seats, make sure that hands or other body parts do not get under the lever assembly of the seat adjustment system.

⚠ WARNING Risk of injury due to head restraints which are not fitted or are adjusted incorrectly

If head restraints are not fitted or are adjusted incorrectly, they cannot provide protection as intended.

There is an increased risk of injury in the head and neck area, e.g. in the event of an accident or when braking.

- ▶ Always drive with the head restraints fitted.
- ▶ Before driving off, make sure for every vehicle occupant that the centre of the head restraint supports the back of the head at about eye level.

Do not interchange the head restraints of the front and rear seats. Otherwise, you cannot adjust the height and angle of the head restraints correctly.

Adjust the head restraint fore-and-aft position so that it is as close as possible to the back of your head.

⚠ WARNING Risk of injury or death due to incorrect seat position

The seat belt does not offer the intended level of protection if you have not moved the seat backrest to an almost vertical position.

When braking or in the event of an accident, you could slide underneath the seat belt and sustain abdominal or neck injuries, for example.

- ▶ Adjust the seat properly before beginning your journey.
- ▶ Always ensure that the seat backrest is in an almost vertical position and that the shoulder section of your seat belt is routed across the centre of your shoulder.

! **NOTE** Damage to the seats when moving the seats back

The seats may be damaged by objects when moving the seats back.

- ▶ When moving the seats back, make sure that there are no objects in the footwell or under or behind the seats.

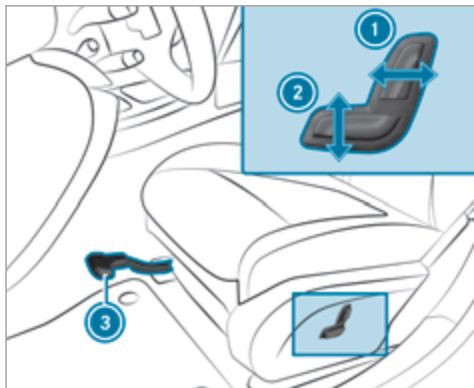

- ① Seat backrest inclination
- ② Seat height
- ③ Seat fore-and-aft adjustment

- ▶ **To adjust the seat fore-and-aft position:** lift lever ③ and slide the seat into the desired position.
- ▶ Make sure that the seat is engaged.

Adjusting the front seat manually and electrically (with Seat Comfort Package)

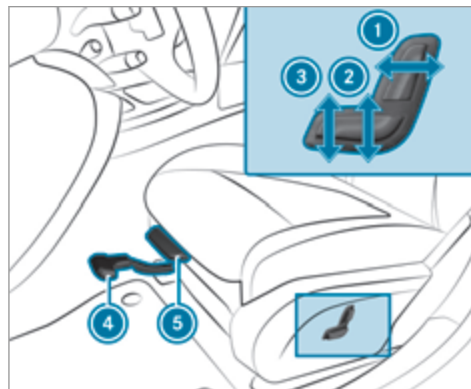

- ① Seat backrest inclination
- ② Seat height
- ③ Seat cushion inclination
- ④ Seat fore-and-aft adjustment
- ⑤ Seat cushion length

- ▶ **To adjust the seat fore-and-aft position:** lift lever ④ and slide the seat into the desired position.
- ▶ Make sure that the seat is engaged.
- ▶ **To adjust the seat cushion length:** lift lever ⑤ and slide the front section of the seat cushion forwards or backwards.

Adjusting the front seat electrically

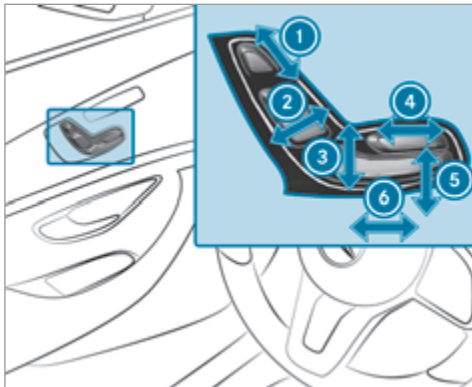

- ① Head restraint height
- ② Seat backrest inclination
- ③ Seat height
- ④ Seat cushion length
- ⑤ Seat cushion inclination
- ⑥ Seat fore-and-aft adjustment

- ▶ Save the settings with the memory function (→ page 106).

Adjusting the front passenger seat from the driver's seat electrically

Requirements:

- The power supply is switched on.

This function is only available on vehicles with an electrically adjustable front passenger seat.

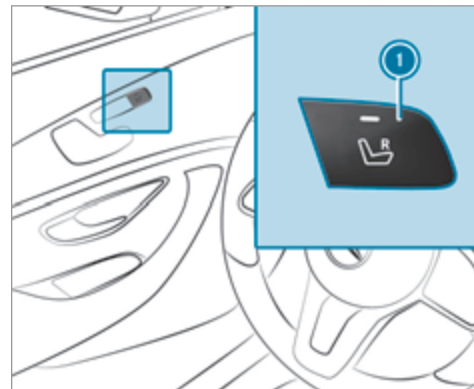

You can call up the following functions for the front passenger seat:

- Seat adjustment
- Seat heater
- Seat ventilation
- Memory function

- ▶ **To select the front passenger seat:** press button ❶.
When the indicator lamp lights up, the front passenger seat is selected.
- ▶ Adjust the front passenger seat using the buttons in the door control panel on the driver's side.

Adjusting the 4-way lumbar support

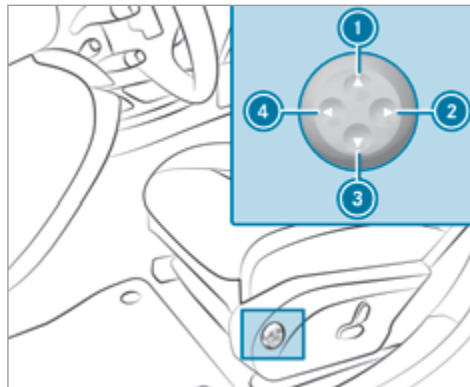

- ❶ To raise
- ❷ To soften
- ❸ To lower
- ❹ To harden

- ▶ Using buttons ❶ to ❹, adjust the contour of the backrest individually to suit your back.

Head restraints

Adjusting the front seat head restraints manually

⚠ WARNING Risk of injury through adjusting vehicle settings while the vehicle is in motion

You could lose control of the vehicle in the following situations:

- if you adjust the driver's seat, the head restraints, the steering wheel or the mirror while the vehicle is in motion
 - if you fasten your seat belt while the vehicle is in motion
- ▶ Before starting the engine: adjust the driver's seat, the head restraints, the steering wheel or the mirror and fasten your seat belt.

⚠ WARNING Risk of injury due to head restraints which are not fitted or are adjusted incorrectly

If head restraints are not fitted or are adjusted incorrectly, they cannot provide protection as intended.

There is an increased risk of injury in the head and neck area, e.g. in the event of an accident or when braking.

- ▶ Always drive with the head restraints fitted.
- ▶ Before driving off, make sure for every vehicle occupant that the centre of the head restraint supports the back of the head at about eye level.

Do not interchange the head restraints of the front and rear seats. Otherwise, you cannot adjust the height and angle of the head restraints correctly.

Adjust the head restraint fore-and-aft position so that it is as close as possible to the back of your head.

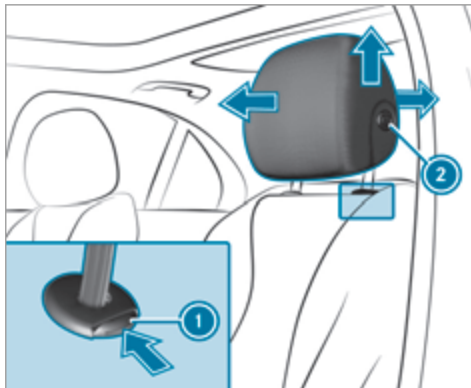

- ▶ **To raise:** pull the head restraint up.
- ▶ **To lower:** press release knob ① in the direction of the arrow and push the head restraint down.
- ▶ **To move forwards:** pull the head restraint forwards.
- ▶ **To move backwards:** press release knob ② and push the head restraint backwards.

Adjusting the front seat luxury head restraints manually

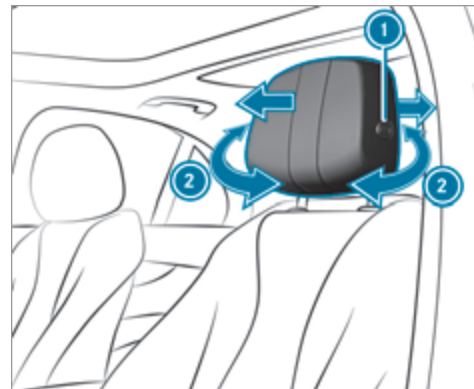

- ▶ **To adjust the side bolsters of the head restraint:** pull or push right or left-hand side bolster ②.
- ▶ **To move forwards:** pull the head restraint forwards.

- ▶ **To move backwards:** press release knob ❶ and push the head restraint backwards.

Adjusting the head restraints of the rear seats mechanically

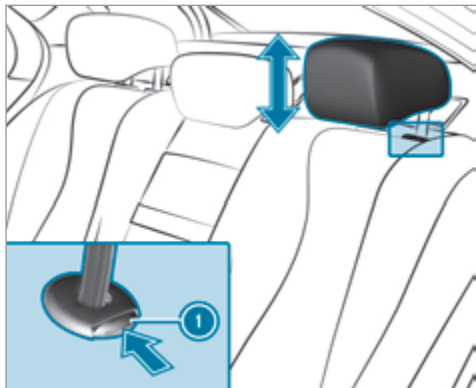

- ▶ **To raise:** pull the head restraint up.
- ▶ **To lower:** press release knob ❶ in the direction of the arrow and push the head restraint down.

Fitting/removing the rear seat head restraints

Removing

The head restraints can only be removed on vehicles with folding rear seat backrests.

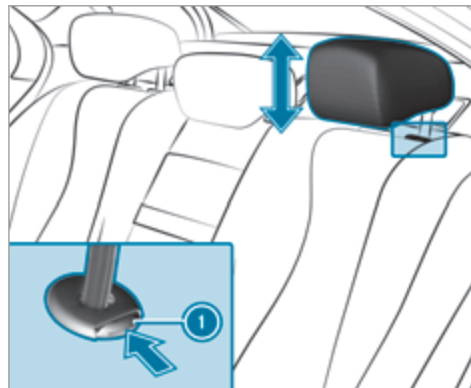

- ▶ Release the rear seat backrest and fold it slightly forwards (→ page 110).

- ▶ Pull the head restraint upwards as far as it will go.
- ▶ Push release knob ❶ in the direction of the arrow and pull out the head restraint.

Fitting

- ▶ Insert the head restraint such that the notches on the bar are on the left when viewed in the direction of travel.
- ▶ Push the head restraint down until you hear it engage in position.
- ▶ Fold the rear seat backrest back until it engages.

Switching the seat heater on/off

⚠ WARNING Risk of burns due to repeatedly switching on the seat heater

Repeatedly switching on the seat heater can cause the seat cushion and seat backrest padding to become very hot.

The health of persons with limited temperature sensitivity or a limited ability to react to

excessively high temperatures may be affected or they may even suffer burn-like injuries.

- ▶ Do not repeatedly switch on the seat heater.

! **NOTE** Damage to the seats caused by objects or documents when the seat heater is switched on

When the seat heater is switched on, overheating can occur due to objects or documents placed on the seats e.g. seat cushions or child seats. This could cause damage to the seat surface.

- ▶ Make sure that no objects or documents are on the seats when the seat heater is switched on.

Requirements:

- The power supply is switched on.

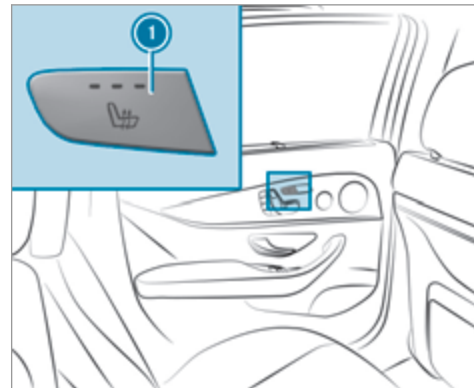
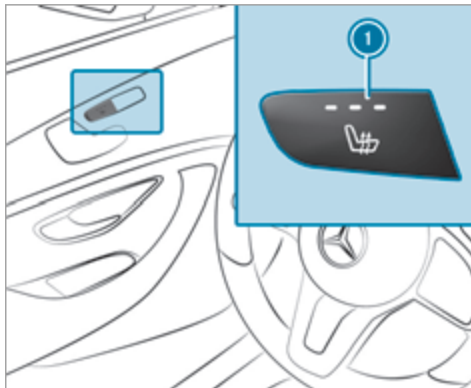

- ▶ **To switch on/increase the level:** press button ① repeatedly until the desired heating level is set. Depending on the heating level, up to three indicator lamps light up.

- ▶ **To switch off/reduce the level:** press button ① repeatedly until the desired heating level is set.
If all indicator lamps are off, the seat heater is switched off.

- ① The seat heater automatically switches down from the three heating levels after 8, 10 and 20 minutes until the seat heater is switched off.

Switching the seat ventilation on/off

Requirements:

- The power supply is switched on.

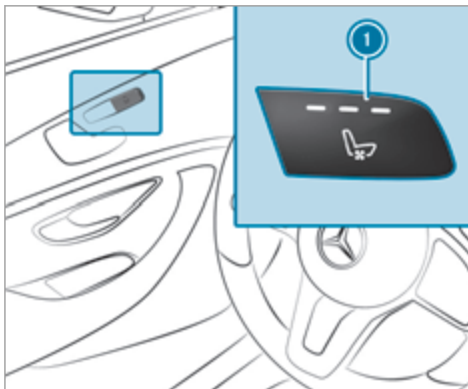

- ▶ **To switch on/increase the level:** press button ① repeatedly until the desired ventilation level is set.
Depending on the ventilation level, up to three indicator lamps light up.

- ▶ **To switch off/reduce the level:** press button ① repeatedly until the desired ventilation level is set.
If all indicator lamps are off, the seat ventilation is switched off.

Steering wheel

Adjusting the steering wheel manually

- ⚠ **WARNING** Risk of injury through adjusting vehicle settings while the vehicle is in motion

You could lose control of the vehicle in the following situations:

- if you adjust the driver's seat, the head restraints, the steering wheel or the mirror while the vehicle is in motion
 - if you fasten your seat belt while the vehicle is in motion
- ▶ Before starting the engine: adjust the driver's seat, the head restraints, the

steering wheel or the mirror and fasten your seat belt.

⚠ WARNING Risk of entrapment for children when adjusting the steering wheel

Children could injure themselves if they adjust the steering wheel.

- ▶ Never leave children unattended in the vehicle.
- ▶ When leaving the vehicle, always take the key with you and lock the vehicle. This also applies to mobile phones if the "Digital Car Key in the smartphone" function is activated via the Mercedes connect me web app.

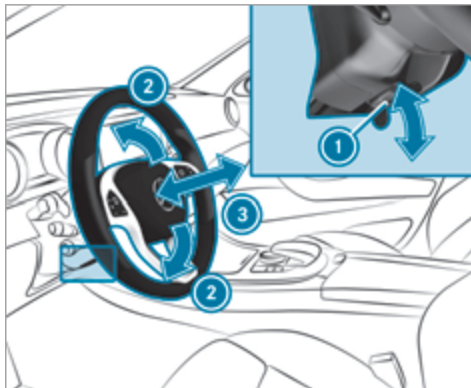

- ▶ Push release lever ① down as far as it will go. The steering column is unlocked.
- ▶ Adjust height ② and distance ③ to the steering wheel.
- ▶ Push release lever ① up as far as it will go. The steering column is locked.
- ▶ Check and make sure that the steering column is locked by moving the steering wheel.

Adjusting the steering wheel electrically

The steering wheel can be adjusted when the power supply is switched off.

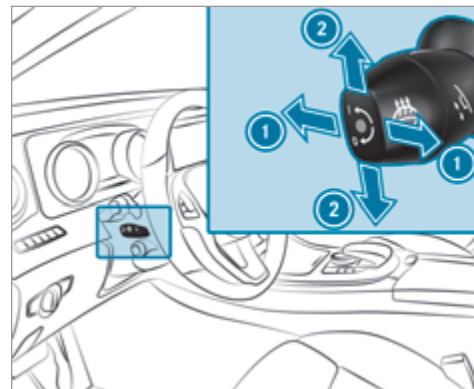

- ① Adjusts the distance to the steering wheel
- ② Adjusts the height
- ▶ Save the settings with the memory function (→ page 106).

Switching the steering wheel heater on/off

Requirements:

- The power supply or the ignition is switched on.

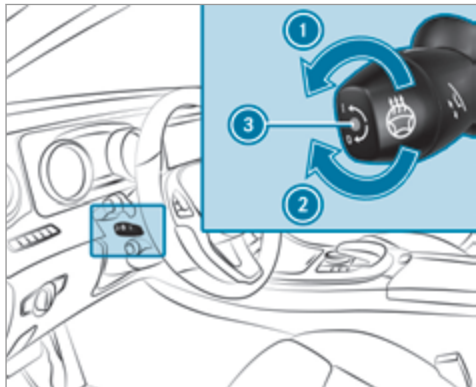

- ▶ **To switch on/off:** turn the lever in the direction of arrow ① or ②. If indicator lamp ③ lights up, the steering wheel heater is switched on.

Easy entry and exit feature

Function of the easy entry and exit feature

⚠ WARNING Risk of accident when pulling away during the adjustment process of the easy exit feature

- If you pull away while the easy entry and exit feature is making adjustments, you could lose control of the vehicle.

- ▶ Always wait until the adjustment process is complete before pulling away.

⚠ WARNING Risk of becoming trapped while adjusting the easy entry and exit feature

When the easy entry and exit feature adjusts the steering wheel, you and other vehicle occupants – particularly children – could become trapped.

- ▶ During the adjustment process of the easy entry and exit feature, make sure

that no one has any body parts in the sweep of the steering wheel.

- ▶ Move the adjustment lever of the steering wheel if there is a risk of becoming trapped by the steering wheel. The adjustment process is stopped.
- ▶ Never leave children unattended in the vehicle.
- ▶ When leaving the vehicle, always take the key with you and lock the vehicle. This also applies to mobile phones if the "Digital Car Key in the smartphone" function is activated via the Mercedes connect me web App.

Vehicles with memory function: you can stop the adjustment process by pressing one of the memory position buttons of the memory function.

If the easy entry and exit feature is active, the steering wheel will move upwards in the following situations:

- you switch the ignition off

- you open the driver's door when the ignition is switched on

The steering wheel moves back to the last drive position in the following cases:

- you switch the ignition on when the driver's door is closed
- you close the driver's door when the ignition is switched on

The last drive position of the steering wheel is stored in the following situations:

- you switch the ignition off
- **Vehicles with memory function:** save the seat settings via the memory function.

Vehicles with memory function: press one of the memory function saved position buttons to stop the adjustment process.

Setting the easy entry and exit feature

Multimedia system:

 [Vehicle](#)  [Vehicle settings](#)  [Easy Entry/Exit](#)

 Activate or deactivate the function.

Using the memory function

 **WARNING** Risk of an accident if memory function is used while driving

If you use the memory function on the driver's side while driving, you could lose control of the vehicle as a result of the adjustments being made.

- ▶ Only use the memory function on the driver's side when the vehicle is stationary.

 **WARNING** Risk of entrapment when setting the seat with the memory function

If you use the memory function to set the seat or the steering wheel, you and other vehicle occupants, especially children, could be entrapped.

- ▶ During the setting procedure of the memory function, ensure that no body parts are in the sweep of the seat or the steering wheel.

- ▶ If somebody becomes trapped, immediately release the memory function position button.
The adjustment process is stopped.

 **WARNING** Risk of entrapment if the memory function is activated by children

Children could become trapped if they activate the memory function, particularly when unattended.

- ▶ Never leave children unattended in the vehicle.
- ▶ When leaving the vehicle, always take the key with you and lock the vehicle. This also applies to mobile phones if the "Digital Car Key in the smartphone" function is activated via the Mercedes connect me web app.

The memory function can be used when the ignition is switched off.

Storing

Seat adjustments for up to three people can be stored and called up using the memory function.

The following systems can be selected:

- Seat, backrest and head restraint
- Steering wheel
- Outside mirrors
- Head-up display

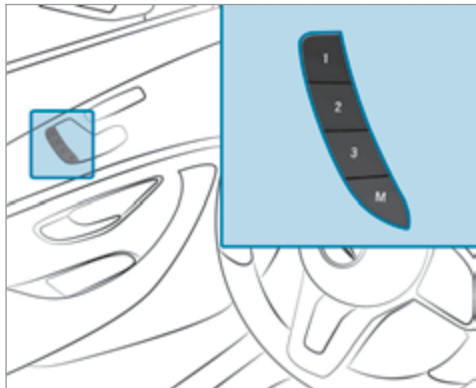

- ▶ Set the seat, the steering wheel, the head-up display and the outside mirror to the desired position.
- ▶ Press memory button M together with one of the storage position buttons 1, 2 or 3. An acoustic signal sounds. The settings are stored.
- ▶ **To call up:** press and hold the relevant pre-set position button 1, 2 or 3 until the front seat, the steering wheel, head-up display and outside mirror is in the stored position.

Stowage areas

Notes on loading the vehicle

⚠ WARNING Risk of exhaust gas poisoning

Combustion engines emit poisonous exhaust gases such as carbon monoxide. Exhaust gases can enter the vehicle interior if the boot lid is open when the engine is running, especially if the vehicle is in motion.

- ▶ Always switch off the engine before opening the boot lid.

- ▶ Never drive with the boot lid open.

⚠ WARNING Risk of injury from unsecured items in the vehicle

If objects, luggage or loads are not secured or not secured sufficiently, they could slip, tip over or be thrown around and thereby hit vehicle occupants.

There is a risk of injury, particularly in the event of sudden braking or a sudden change in direction.

- ▶ Always stow objects in such a way that they cannot be thrown around.
- ▶ Before the journey, secure objects, luggage or loads against slipping or tipping over.

⚠ WARNING Risk of injury from incorrectly stowed objects

If objects in the passenger compartment are stowed incorrectly, they can slide or be thrown around and hit vehicle occupants. In

addition, cup holders, open stowage spaces and mobile phone brackets cannot always retain all objects they contain.

There is a risk of injury, particularly in the event of sudden braking or a sudden change in direction.

- ▶ Always stow objects so that they cannot be thrown around in such situations.
- ▶ Always make sure that objects do not protrude from stowage spaces, luggage nets or stowage nets.
- ▶ Close the lockable stowage spaces before starting a journey.
- ▶ Always stow and secure heavy, hard, pointed, sharp-edged, fragile or bulky objects in the boot.

⚠ WARNING Risk of burns from tailpipes and tailpipe trim

The tailpipe and tailpipe trim can become very hot. If you come into contact with these parts of the vehicle, you could burn yourself.

- ▶ Always be particularly careful around the tailpipe and the tailpipe trim.
- ▶ Allow the vehicle parts to cool down before you touch them.

The handling characteristics of your vehicle are dependent on the distribution of the load within the vehicle. You should bear the following in mind when loading the vehicle:

- never exceed the maximum gross vehicle weight or the permissible axle loads for the vehicle (including occupants).
- the load must not protrude above the upper edge of the seat backrests.
- always place the load behind unoccupied seats if possible.
- secure the load using the tie-down eyes and distribute the load evenly.

Stowage spaces in the vehicle interior

Overview of the front stowage compartments

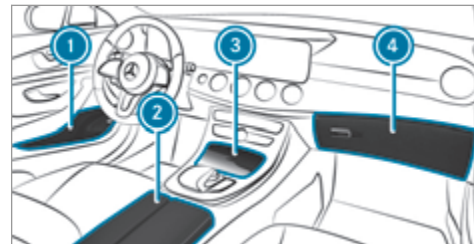

- ① Stowage compartment in the doors
- ② Stowage/telephone compartment in the armrest with multimedia connections and stowage compartment, e.g. for an MP3 player
- ③ Stowage compartment in the front centre console with a USB port (depending on the vehicle's equipment)
- ④ Glove box

Locking or unlocking the glove box

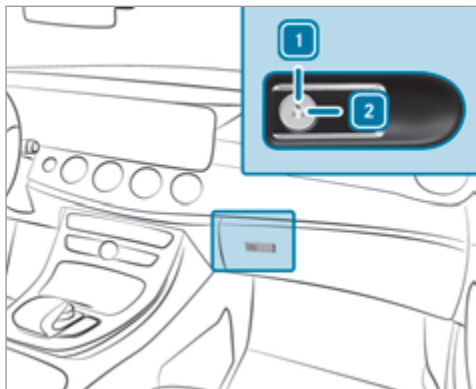

- ▶ Turn the emergency key a quarter turn clockwise **2** (to lock) or anti-clockwise **1** (to unlock).

Opening the spectacles compartment



- ▶ Press button **1**.

Opening the stowage compartment in the rear armrest

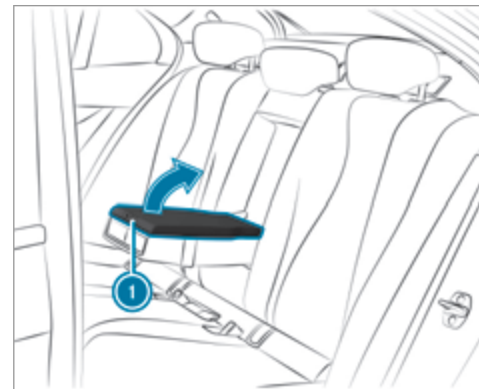

- ▶ Press release catch **1** and swing the cover of the armrest upwards.

Through-loading feature in the rear bench seat

Folding the rear seat backrest forwards

⚠ WARNING Risk of injury if the rear bench seat/rear seat and seat backrest are not engaged

If the rear bench seat/rear seat and seat backrest are not engaged they could fold forwards, e.g. when braking suddenly or in the event of an accident.

- If this is the case, the vehicle occupant would be forced into the seat belt by the rear bench seat/rear seat or by the seat backrest. The seat belt cannot protect as intended and could result in additional injury.
- Objects or loads in the boot cannot be restrained by the seat backrest.

▶ Make sure that the seat backrest and the rear bench seat/rear seat are engaged before every trip.

Requirements:

- The rear seat backrest head restraints are fully inserted.
- The centre seat backrest has been unlocked.

If the seat backrest is not engaged and locked, this will be shown on the multifunction display on the instrument cluster.

The centre and outer seat backrests can be folded forwards separately.

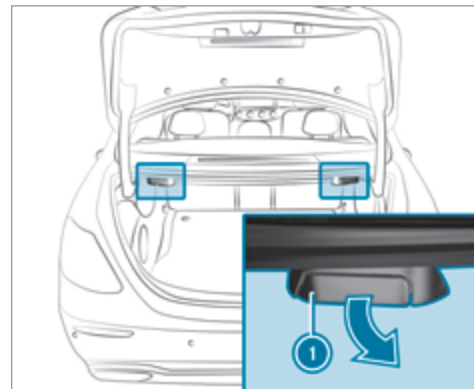

▶ **Left and right seat backrest:** pull release lever ①.

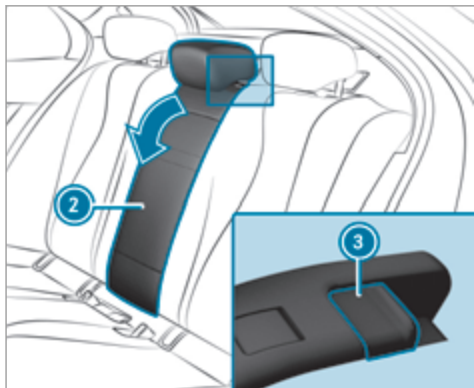

- ▶ **Centre seat backrest:** pull release catch ③ of seat backrest ② forwards.
- ▶ Fold the corresponding seat backrest forwards.

Folding the rear seat backrest back

1 NOTE Damage to the seat belt

The seat belt could become trapped and thus damaged when folding back the seat backrest.

- ▶ Make sure that the seat belt is not trapped when folding back the seat backrest.

- ▶ Move the driver's or front passenger seat forwards, if necessary.

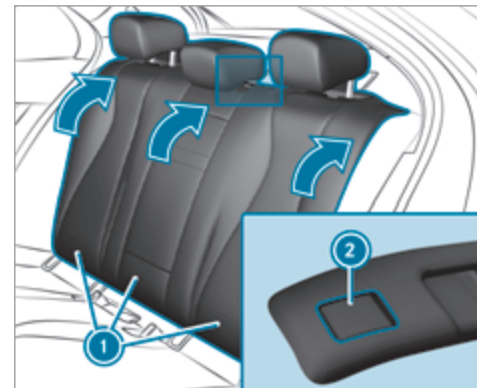

- ▶ Fold corresponding seat backrest ① back until it engages.
- Left and right seat backrests:** if the seat backrest is not engaged and locked, this will be shown on the multifunction display on the instrument cluster.
- Centre seat backrest:** if the seat backrest is not engaged and locked, red lock verification indicator ② will be visible.

Blocking the release catch of the centre rear seat backrest

Requirements:

- The left and centre seat backrest are engaged and joined together.

Lock the centre seat backrest release catch if you want to secure the boot from unauthorised access. The centre seat backrest can then only be folded forwards together with the left seat backrest.

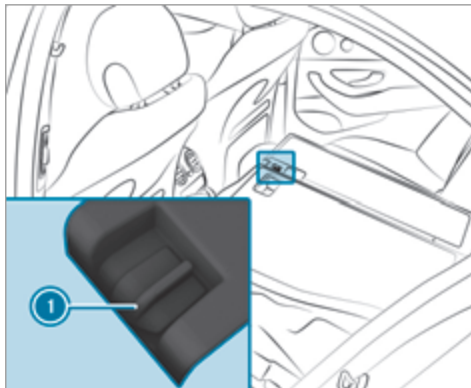

- ▶ Fold the centre and left seat backrest forwards.
- ▶ **To lock:** slide catch ❶ upwards. The release mechanism of the centre seat backrest is locked.
- ▶ **To unlock:** slide catch ❶ downwards.

Securing the ski and snowboard bag in the boot

⚠ WARNING Risk of injury due to using the through-load ski bag incorrectly

The through-load ski bag in conjunction with the lashing straps cannot restrain any objects other than skis.

Vehicle occupants could be struck in the event of sudden braking or an accident in the following cases:

- If you transport other heavy or sharp-edged objects in the through-load ski bag
 - If you do not secure the through-load ski bag with the lashing straps
- ▶ Only store skis in the through-load ski bag.
 - ▶ Always secure the through-load ski bag with the lashing straps so that it cannot move around.

A maximum of four pairs of skis or two snowboards may be transported in the ski and snowboard bag.

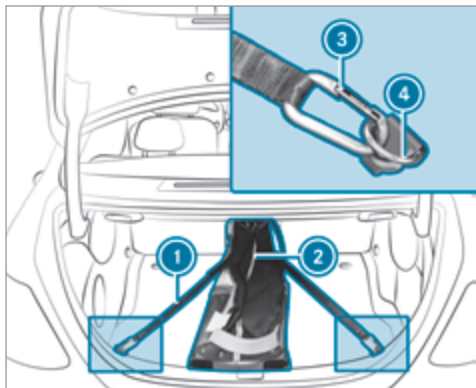

- ▶ Fold the centre rear seat backrest forwards.
- ▶ Slide the ski and snowboard bag between the outer seat backrests into the rear.
- ▶ Open zip ②.

- ▶ Load the ski and snowboard bag with the skis or snowboards.
- ▶ Close zip ②.
- ▶ Pull the tensioning strap tight by the loose end.
- ▶ Cross lashing straps ①.
- ▶ Engage hooks ③ of lashing straps ① in tie-down eyes ④. Make sure that the fasteners of hooks ③ are facing upwards.

Overview of the tie-down eyes

Observe the notes on loading the vehicle (→ page 107).

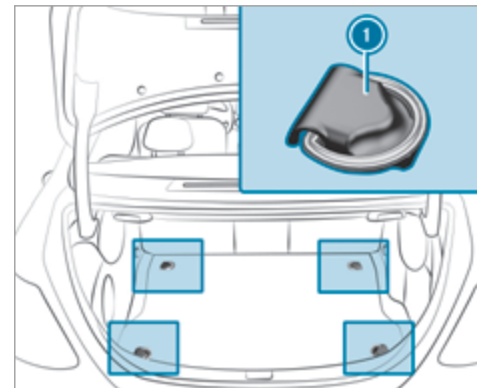

- ① Tie-down eyes (vehicles with through-loading feature in the rear bench seat)

Hooking the luggage net

⚠ WARNING Risk of injury from incorrectly stowed objects

If objects in the passenger compartment are stowed incorrectly, they can slide or be thrown around and hit vehicle occupants. In addition, cup holders, open stowage spaces and mobile phone brackets cannot always retain all objects they contain.

There is a risk of injury, particularly in the event of sudden braking or a sudden change in direction.

- ▶ Always stow objects so that they cannot be thrown around in such situations.
- ▶ Always make sure that objects do not protrude from stowage spaces, luggage nets or stowage nets.
- ▶ Close the lockable stowage spaces before starting a journey.

- ▶ Always stow and secure heavy, hard, pointed, sharp-edged, fragile or bulky objects in the boot.

Observe the notes on loading the vehicle.

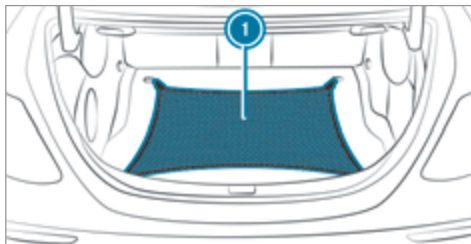

- ▶ **Vehicles with through-loading feature in the rear bench seat:** fold up the tie-down eye.
- ▶ Hook the luggage net ① into the front and rear tie-down eyes.
- ▶ **Vehicles without a through-loading feature in the rear bench seat:** hook the rings into the luggage net's hooks ①.

- ▶ Hook the rings into the hooks on the boot floor.

EASY-PACK boot box

Adjusting the height of the EASY-PACK boot box to any position

⚠ WARNING Risk of becoming trapped and injured when moving the floor up

When the floor moves up, your hands may become trapped on the frame of the EASY-PACK boot box and objects may be thrown upwards.

- ▶ When the floor moves up, make sure that your hands are not within the sweep of the floor.
- ▶ If someone becomes trapped, carefully push the centre of the floor downward.
- ▶ Remove all objects from the floor before moving it up.

⚠ WARNING Risk of becoming trapped when pressing the EASY-PACK boot box in

When the EASY-PACK boot box is pressed into the retracted position, your hands may become trapped. Children, in particular, may injure themselves when doing so.

- ▶ When pressing the EASY-PACK boot box in, make sure that your hands are not within the sweep of the EASY-PACK boot box.
- ▶ When leaving the vehicle, always take the key with you and lock the vehicle. This also applies to mobile phones if the "digital vehicle key in the smartphone" function is activated via the Mercedes connect me web app.
- ▶ Never leave children unattended in the vehicle.

! NOTE Damage to the extended EASY-PACK boot box

The EASY-PACK boot box may be damaged when it is extended.

- ▶ Do not place any objects on or press down on the EASY-PACK boot box frame.
- ▶ Do not close the boot lid when the EASY-PACK boot box is extended.

! NOTE Damage to the EASY-PACK boot box by objects

Objects which are sharp-edged, pointed, fragile, rounded or heavy and objects that roll can damage the EASY-PACK boot box and be thrown out.

- ▶ Do not transport objects which are sharp-edged, pointed, rounded or fragile and objects that roll in the EASY-PACK boot box.
- ▶ Always stow and secure such objects outside of the box in the boot.

- ▶ Always observe the maximum permitted load of the EASY-PACK boot box.
- ▶ Do not use the EASY-PACK boot box when the rear seats are folded forwards.

The maximum permitted load of the EASY-PACK boot box is 10 kg. To prevent the box from being overloaded, the box floor lowers onto the boot floor when the load reaches approximately 5 kg.

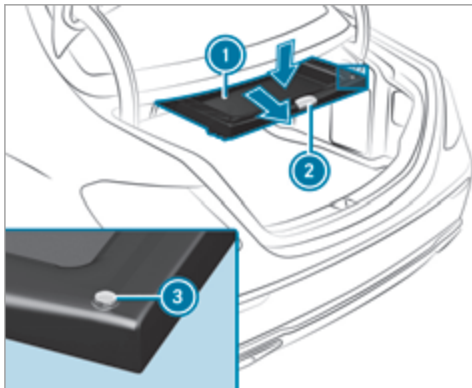

- ▶ **To remove:** pull handle ② of the box.
- ▶ **To increase the load capacity:** press the centre of floor ① downwards to the desired position and box size.
- ▶ **To reduce the load capacity:** press button ③.
- ▶ **To stow:** press the box in completely using handle ② until it locks in place.

ⓘ Observe the notes on cleaning the EASY-PACK boot box (→ page 319).

Installing or removing the EASY-PACK boot box

Fitting

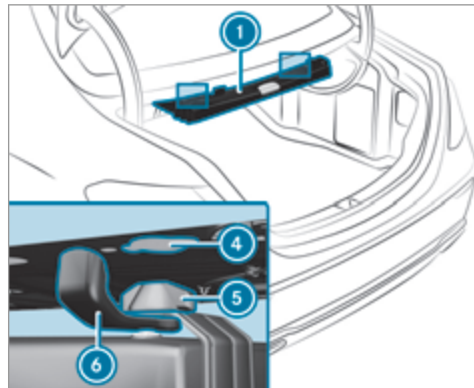
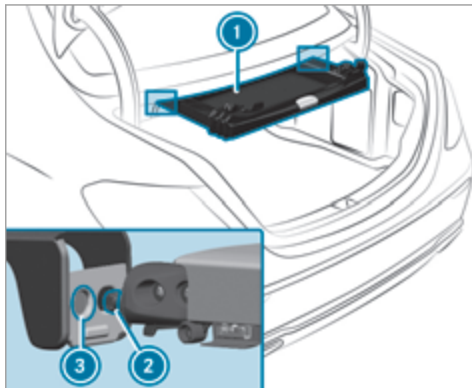

- ▶ Turn rotating catches ⑥ outward.
- ▶ Insert retainers ② of box ① into outer holes ③.
- ▶ Raise box ① and press hooks ⑤ into rear shelf ④.
- ▶ Turn rotating catches ⑥ inward.

Removing

- ▶ Turn rotating catches ⑥ outward.
- ▶ Lower box ① and pull it out of anchorages ④.
- ▶ Pull box ① back out of openings ③.

Opening the stowage space under the boot floor

! **NOTE** Damage to the handle in the boot floor

If the handle in the boot is left protruding, the handle may be damaged.

- ▶ Unhinge the handle before you close the boot lid and press the handle closed again.

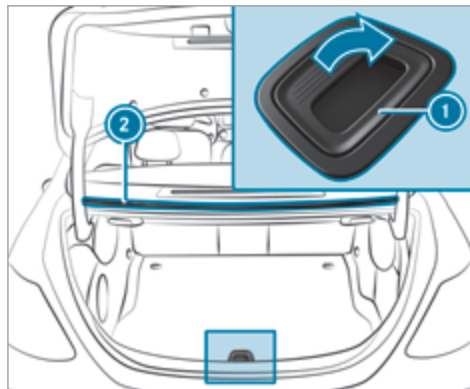

- ▶ Pull handle ① up and hook it into drip rail ②.

Attaching the roof rack

! **WARNING** Risk of injury by exceeding the maximum roof load

When you load the roof, the vehicle centre of gravity rises and the driving characteristics change.

If you exceed the maximum roof load, the driving characteristics, as well as the steering and braking, will be greatly impaired.

- ▶ Never exceed the maximum roof load and adjust your driving style.

You will find information on the maximum roof load in the "Technical data" section.

! **NOTE** Vehicle damage from non-approved roof racks

The vehicle could be damaged by roof racks which have not been tested and approved by Mercedes-Benz.

- ▶ Only use roof racks tested and approved by Mercedes-Benz.

- ▶ Depending on the vehicle equipment, ensure that when the roof rack is fitted:
 - the sliding sunroof can be fully raised.
 - the boot lid can be fully opened.
- ▶ Position the load on the roof rack in such a way that the vehicle will not sustain damage even when it is in motion.

! **NOTE** Damage to the panoramic sliding sunroof when a roof rack is fitted

The panoramic sliding sunroof may be damaged by the roof rack if you attempt to open it when the roof rack is fitted.

- ▶ Do not open the panoramic sliding sunroof if a roof rack is fitted.

In order to allow ventilation of the vehicle interior, you can raise the panoramic sliding sunroof.

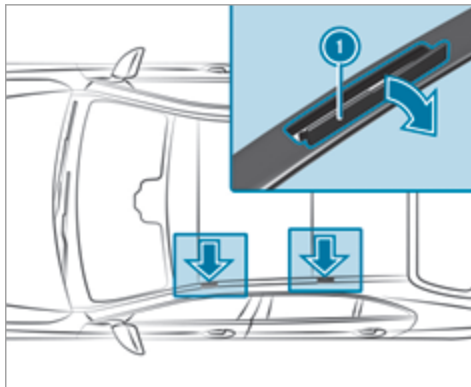

! **NOTE** Damage to the covers

The covers may be damaged and scratched when being opened.

- ▶ Do not use metallic or hard objects.

- ▶ Fold covers ① carefully upwards in the direction of the arrow.

- ▶ Secure the roof rack to the anchorage points under covers ①.
- ▶ Comply with the roof rack manufacturer's installation instructions.
- ▶ Secure the load on the roof rack.

Cup holders

Fitting the cup holder in or removing it from the centre console (automatic transmission)

! **WARNING** - Risk of accident or injury when using the cup holder while the vehicle is in motion

The cup holder cannot hold a container secure while the vehicle is in motion.

If you use a cup holder while the vehicle is in motion, the container may be flung around and liquids could be spilled. The vehicle occupants may come into contact with the liquid and if it is hot, they could be scalded. You could be distracted from traffic conditions and you may lose control of the vehicle.

- ▶ Only use the cup holder when the vehicle is stationary.
- ▶ Only use the cup holder for containers of the right size.
- ▶ Always close the container, particularly if the liquid is hot.

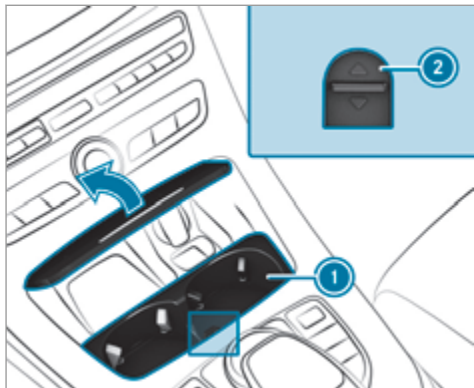

- ▶ **To remove:** slide catch ② forwards and pull out cup holder ①.
 - ▶ **To fit:** insert cup holder ① and slide back catch ②.
- ⓘ The cup holder rubber mat can be removed for cleaning, e.g. using clean, lukewarm water.

Fitting the cup holder in, or removing it from, the centre console (manual transmission)

⚠ WARNING - Risk of accident or injury when using the cup holder while the vehicle is in motion

The cup holder cannot hold a container secure while the vehicle is in motion. If you use a cup holder while the vehicle is in motion, the container may be flung around and liquids could be spilled. The vehicle occupants may come into contact with the liquid and if it is hot, they could be scalded. You could be distracted from traffic conditions and you may lose control of the vehicle.

- ▶ Only use the cup holder when the vehicle is stationary.
- ▶ Only use the cup holder for containers of the right size.
- ▶ Always close the container, particularly if the liquid is hot.

Removing



- ▶ Slide both cup holder sections ① inwards until they engage.
- ▶ Slide the cup holder forwards and remove cup holder ②.

Fitting

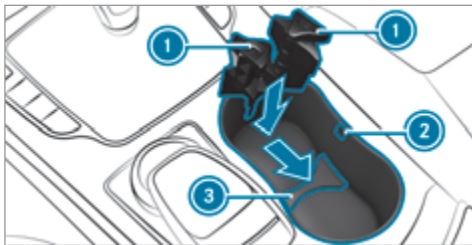

- ▶ Insert the cup holder at the front and slide it as far as the edge ③. The wedge of the upper section of the cup holder must face upwards.
- ▶ Slide upper cup holder sections ① outwards until both right and left sides ② engage.
- ① The cup holder rubber mat can be removed for cleaning, e.g. using clean, lukewarm water.

Opening the cup holder in the rear armrest

! **NOTE** Damage to the cup holder

When the rear armrest is folded back the cup holder could become damaged.

- ▶ Only fold the rear armrest back when the cup holder is closed.

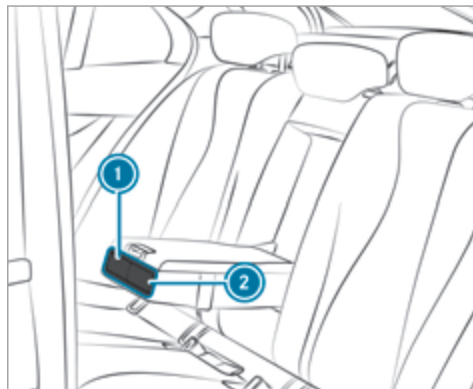

- ▶ Press cup holder ① or ②.
- ▶ Place a container in or remove a container from cup holder ① or ②.

Ashtray and cigarette lighter

Using the ashtray in the front centre console

! **NOTE** Damage to the stowage compartment under the ashtray

The stowage compartment under the ashtray is not heat resistant and could be damaged if you rest lit cigarettes on it.

- ▶ Ensure that the ashtray is fully engaged.

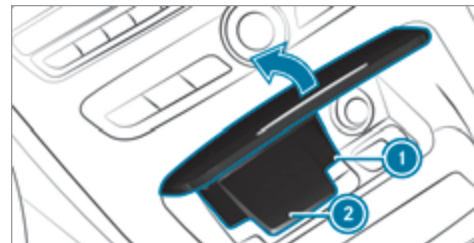

- ▶ **To open:** push up the cover ② of the ashtray on its right or left side.
- ▶ **To remove the insert:** press insert ① upwards slightly and pull it out upwards.
- ▶ **To refit the insert:** press insert ① into the holder until it engages.

Using the rear ashtray

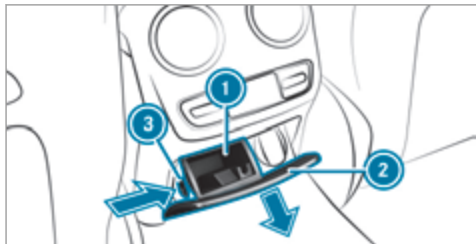

- ▶ **To open:** pull cover ② out by its top handle edge.
- ▶ **To remove the insert:** push ribbing ③ from the left side and pull insert ① upwards and out.

- ▶ **To fit the insert:** fit insert ① from above and press down into the holder until it engages.

Using the cigarette lighter

⚠ WARNING - Risk of fire and injury from the hot cigarette lighter

You can burn yourself if you touch the hot heating element or the socket of the cigarette lighter.

In addition, flammable materials may ignite if:

- you drop the hot cigarette lighter
- a child holds the hot cigarette lighter to objects, for example
 - ▶ Always hold the cigarette lighter by the knob.
 - ▶ Always make sure that the cigarette lighter is out of reach of children.
 - ▶ Never leave children unattended in the vehicle.

Requirements:

- the ignition is switched on.

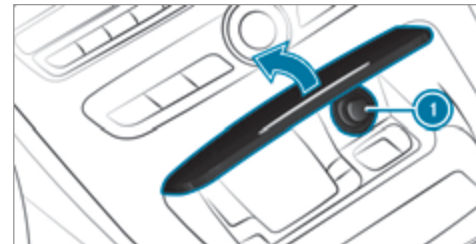

- ▶ Press in cigarette lighter ①. The cigarette lighter will pop out automatically when the heating element is red-hot.

Sockets

12 V socket in the front centre console

Requirements:

- Only connect devices up to a maximum of 180 watts (15 A).



- ▶ Lift up cap ① of the socket and insert the plug of the device.

If you have connected a device to the 12 V socket, leave the cover of the stowage compartment open.

Using the 12 V socket in the rear passenger compartment

Requirements:

- Only connect devices up to a maximum of 180 watts (15 A).



- ▶ Briefly press the trim element of cover ②.
- ▶ Lift up cap ① of the socket and insert the plug of the device.

Using the 230 V socket in the rear compartment

- ⚠ **DANGER** Risk of fatal injury due to damaged connecting cables or sockets

When a suitable device is connected, the 230 V power socket will be carrying a high voltage. You could receive an electric shock if the connecting cable or the 230 V power

socket is pulled out of the trim or is damaged or wet.

- ▶ Use only connecting cables that are dry and free of damage.
- ▶ When the ignition is switched off, make sure that the 230 V power socket is dry.
- ▶ Immediately have the 230 V power socket checked or replaced at a qualified specialised workshop if it is damaged or has been pulled out of the trim.
- ▶ Never plug the connecting cable into a 230 V power socket that is damaged or has been pulled out of the trim.

- ⚠ **DANGER** Risk of fatal injury due to incorrect handling of the socket

You could receive an electric shock:

- if you reach into the socket.
- if you insert unsuitable devices or objects into the socket.
- ▶ Only connect suitable devices to the socket.

Requirements:

- Only connect devices with a suitable plug which conforms to the standards specific to the country you are in.
- Only connect devices up to a maximum of 150 watts.
- Do not use multiple socket outlets.

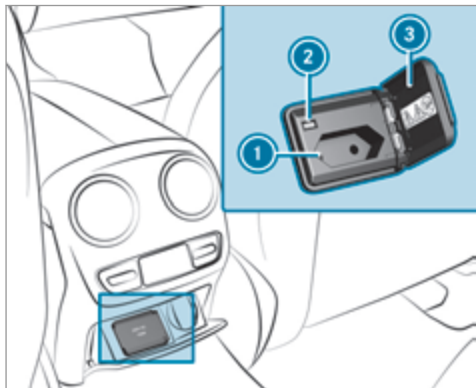

- ▶ Open flap ③.

- ▶ Insert the plug of the device into 230 V socket ①. When the on-board electrical system voltage is sufficient, indicator lamp ② lights up.

Using the 12 V socket in the boot**Requirements:**

- Only connect devices up to a maximum of 180 watts (15 A).

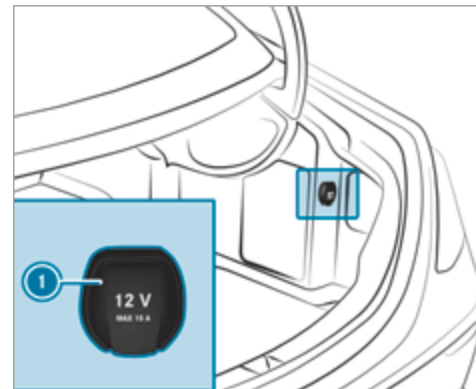

- ▶ Lift up cap ① of the socket and insert the plug of the device.

USB port in the rear

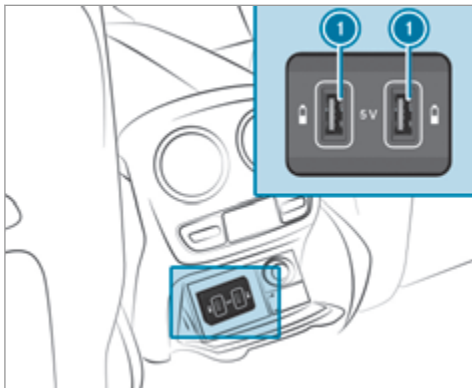

You can charge a USB device, e.g. a mobile phone, at USB ports ① using a suitable charging cable. The devices can be charged with 5 V (2.1 A) and when the ignition is switched on.

Wireless charging of the mobile phone and connection with the exterior aerial

Notes on wireless charging of the mobile phone

⚠ WARNING Risk of injury from incorrectly stowed objects

If objects in the passenger compartment are stowed incorrectly, they can slide or be thrown around and hit vehicle occupants. In addition, cup holders, open stowage spaces and mobile phone brackets cannot always retain all objects they contain.

There is a risk of injury, particularly in the event of sudden braking or a sudden change in direction.

- ▶ Always stow objects so that they cannot be thrown around in such situations.
- ▶ Always make sure that objects do not protrude from stowage spaces, luggage nets or stowage nets.

- ▶ Close the lockable stowage spaces before starting a journey.
- ▶ Always stow and secure heavy, hard, pointed, sharp-edged, fragile or bulky objects in the boot.

Observe the notes on loading the vehicle.

⚠ WARNING Risk of fire from placing objects in the mobile phone stowage compartment

If you place objects in the mobile phone stowage compartment, they may heat up excessively and even catch fire.

- ▶ Do not place additional objects, especially those made of metal, in the mobile phone stowage compartment.

! **NOTE** Damage to objects caused by placing them in the mobile phone stowage compartment

If you place objects in the mobile phone stowage compartment, these may be damaged by electromagnetic fields.

▶ Do not place credit cards, storage media or other objects sensitive to electromagnetic fields in the mobile phone stowage compartment.

! **NOTE** Damage to the mobile phone stowage compartment caused by liquids

If liquids enter the mobile phone stowage compartment, the compartment may be damaged.

▶ Ensure that no liquids enter the mobile phone stowage compartment.

- Depending on the vehicle equipment, the mobile phone is connected to the vehicle's exterior aerial via the charging module.

- The charging function and wireless connection of the mobile phone to the vehicle's exterior aerial are only available if the ignition is switched on.
- Small mobile phones may not be able to be charged in every position of the mobile phone stowage compartment.
- Large mobile phones which do not rest flat in the mobile phone stowage compartment may not be able to be charged or connected with the vehicle's exterior aerial.
- The mobile phone may heat up during the charging process. This depends on the applications (apps) currently running.

The mobile phone can be cooled in the mobile phone stowage compartment when the air conditioning system is switched on. The cooling output in the mobile phone stowage compartment is highest when the controller in the glove box is closed.

- To ensure more efficient charging and connection with the vehicle's exterior aerial, remove the protective cover from the mobile

phone. Protective covers which are designed for wireless charging are excluded.

- When charging, the mat should be used if possible.

Wireless charging of the mobile phone in the front

Requirements:

- The mobile phone is suitable for wireless charging (Qi compatible mobile phone).
- i** A list of Qi compatible mobile phones can be found at: <http://www.mercedes-benz.com/connect>.

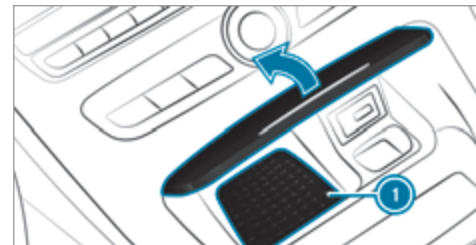

- ▶ Place the mobile phone as close to the centre of mat ① as possible with the display facing upwards.

When the charging symbol is shown in the multimedia system, the mobile phone is being charged.

Malfunctions during the charging process are shown in the multimedia system display.

- ① The mat can be removed for cleaning, e.g. using clean, lukewarm water.

Fitting or removing the floor mats

- ⚠ **WARNING** Risk of accident due to objects in the driver's footwell

Objects in the driver's footwell may impede pedal travel or block a depressed pedal.

This jeopardises the operating and road safety of the vehicle.

- ▶ Stow all objects in the vehicle securely so that they cannot get into the driver's footwell.

- ▶ Always fit the floor mats securely and as prescribed in order to ensure that there is always sufficient room for the pedals.
- ▶ Do not use loose floor mats and do not place floor mats on top of one another.

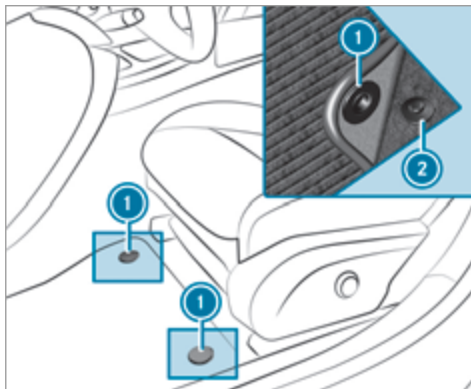

- ▶ **To fit:** press stud ① into holder ②.

- ▶ **To remove:** pull the floor mat off the holders ②.

Exterior lighting

Notes on changing the lights when driving abroad

Vehicles with halogen or static LED headlamps: It is not necessary to change the headlamps. The legal requirements are also met in countries where people drive on the other side of the road.

Vehicles with Intelligent Light System: Before crossing the border into countries where they drive on the other side, it is necessary to set the headlamps to symmetrical dipped beam (→ page 135).

After changing the headlamps:

- Oncoming traffic is not dazzled.
- The edge of the road is not illuminated as far or as high.
- The "motorway mode" and "enhanced fog light" functions are not available.

The headlamps must be reset to asymmetrical dipped beam after returning from abroad.

Lighting systems and your responsibility



The various lighting systems of the vehicle are only aids. The driver of the vehicle is responsible for correct vehicle illumination in accordance with the prevailing light and visibility conditions, legal requirements and traffic situation.

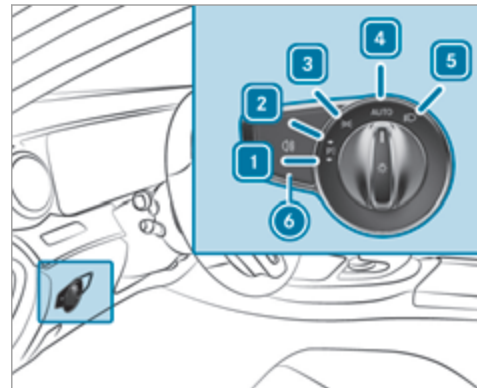

Light switch

Operating the light switch



- 1 Left-hand parking lights
- 2 Right-hand parking lights
- 3 Standing lights and licence plate lighting
- 4 **AUTO** Automatic driving lights (preferred light switch position)



- 5  Dipped beam/main beam
- 6  Switches the rear fog light on or off

When dipped beam is activated, the indicator lamp for the standing lights  is deactivated and replaced by the dipped beam indicator lamp .

- ▶ Always park your vehicle safely and in a well-lit area, in accordance with the relevant legal stipulations.

! **NOTE** Battery discharging by operating the standing lights

Operating the standing lights over a period of hours puts a strain on the battery.

- ▶ Where possible, switch on the right  or left  parking light.

In the case of severe battery discharging, the standing lights or parking lights are automatically switched off to facilitate the next engine start.

The exterior lighting (except standing and parking lights) switches off automatically when the driver's door is opened.

- Observe the notes on surround lighting .

Automatic driving lights function

The standing lights, dipped beam and daytime running lights are switched on automatically depending on the ignition status, whether the engine is running and the light conditions.

! **WARNING** Risk of accident when the dipped beam is switched off in poor visibility



When the light switch is set to **AUTO**, the dipped beam may not be switched on automatically if there is fog, snow or other causes of poor visibility such as spray.

- ▶ In such cases, turn the light switch to .

The automatic driving lights are only an aid. You are responsible for vehicle lighting.

Activating/deactivating the rear fog light

Requirements:

- The light switch is in the  or **AUTO** position.
- ▶ Press the  button.

Please observe the country-specific laws on the use of rear fog lamps.

Adjusting the headlamp range (halogen headlamps without active suspension)

The headlamp range adjuster allows you to adjust the cone of light from the headlamps in relation to the vehicle's load condition.

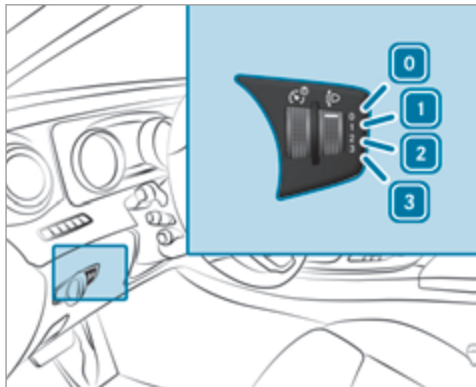

- 0 Driver's seat and front passenger seat occupied
- 1 Driver's seat, front passenger seat and rear seats occupied
- 2 Driver's seat, front passenger seat and rear seats occupied, boot laden
- 3 Driver's seat and front passenger seat occupied and maximum permissible rear axle load utilised

- ▶ Turn the headlamp range adjuster to the position which corresponds to the load condition of your vehicle.

Operating the lights combination switch

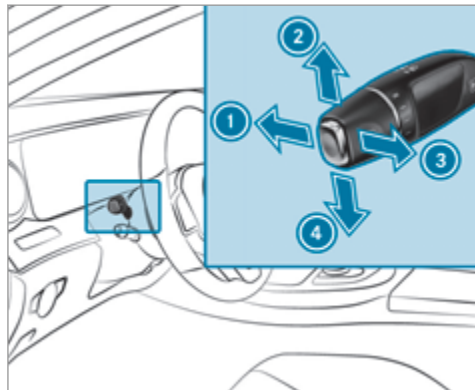



- 1 Main beam
- 2 Turn signal light, right

- 3 Headlamp flasher
- 4 Turn signal light, left

- ▶ Use the combination switch to activate the function in question.

Main beam

- ▶ **To switch on:** turn the light switch to the  or **AUTO** position.
- ▶ Press the combination switch beyond the pressure point in the direction of arrow 1. When the main beam is activated, the indicator lamp for dipped beam  is deactivated and replaced by the indicator lamp for the main beam .
- ▶ **To switch off:** move the combination switch back to its starting position.

Headlamp flasher:

- ▶ Pull the combination switch in the direction of arrow 3.

Turn signal light

- ▶ **To indicate briefly:** press the combination switch briefly up to the pressure point in the direction of arrow ② or ④. The corresponding turn signal light flashes three times.
- ▶ **To indicate permanently:** press the combination switch beyond the pressure point in the direction of arrow ② or ④.

Activating/deactivating the hazard warning light

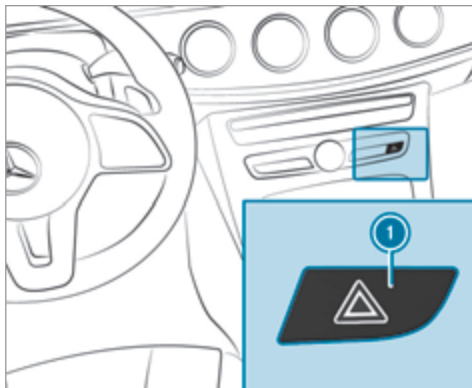

- ▶ Press the ① button.

The hazard warning lamps switch on automatically if:

- The airbag has been deployed.
- The vehicle brakes sharply from a speed of more than 70 km/h to a standstill.

The hazard warning lamps switch off automatically when the vehicle reaches a speed exceeding 10 km/h following maximum full-stop braking.

Adaptive functions, MULTIBEAM LED

Function of the Intelligent Light System

The MULTIBEAM LED headlamps adapt to the driving and weather situation and provide extended functions for improving the illumination of the road.

The system comprises the following functions:

- Active headlamps function (→ page 131)
- Cornering light (→ page 131)
- Motorway mode (→ page 131)
- Enhanced fog light function (→ page 132)
- Adverse weather light (→ page 132)
- City lighting (→ page 132)

The system is only active when it is dark.

Active headlamps function



- The headlamps follow the steering movements.
- Relevant areas are better illuminated while driving.

The functions are active when the dipped beam is switched on.

Depending on the vehicle's equipment, the course of the lane you are driving in is also evaluated and the active headlamps function adjusts the light in advance.

Cornering light function



The cornering light improves the illumination of the carriageway over a wide angle in the turning direction, enabling better visibility on tight bends, for example. It can be activated only when the dipped beam is switched on.

The function is active:

- At speeds below 40 km/h when the turn signal light is switched on or the steering wheel is turned.
- At speeds between 40 km/h and 70 km/h when the steering wheel is turned.

Roundabout and intersection function: the cornering light is activated on both sides through an evaluation of the current GPS position of the vehicle. It remains active until after the vehicle has left the roundabout or the intersection.

Motorway mode function

Motorway mode increases the range and brightness of the cone of light, enabling better visibility.



The function is active if a motorway journey is detected by:

- The vehicle's speed.
- The multifunction camera.

- The GPS.

The function is not active:

- At speeds below 80 km/h.

Enhanced fog light function

The enhanced fog light function reduces glare for the driver and improves the illumination of the edge of the carriageway.

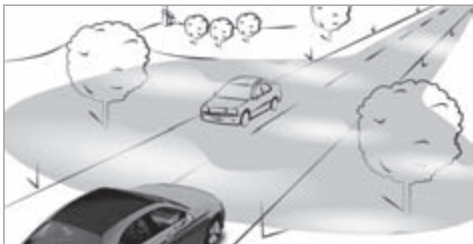

The function is active:

- At speeds below 70 km/h when the rear fog light is switched on.

The function is not active:

- At speeds above 100 km/h after activation.

- When the rear fog light is switched off.

Adverse weather light function

The adverse weather light reduces reflections in rainy conditions by dimming individual LEDs in the headlamps. This reduces the glare for the driver and other road users.

Function of City lighting

City lighting improves the illumination of road-sides within built-up areas using a broader distribution of light.

The function is active:

- at lower speeds
- in illuminated parts of built-up areas.

Switching the Intelligent Light System on/off

Requirements:

the ignition is switched on.

Multimedia system:

➔ [Vehicle](#) ➔ [Lights](#) ➔ [Intelligent Light System](#)

▶ Switch the function on or off.

Adaptive Highbeam Assist

Function of Adaptive Highbeam Assist

⚠ WARNING Risk of accident despite Adaptive Highbeam Assist

Adaptive Highbeam Assist does not recognise the following road users:

- Road users without lights, e.g. pedestrians
- Road users with poor lighting, e.g. cyclists
- Road users whose lighting is obstructed, e.g. by a barrier

On very rare occasions, Adaptive Highbeam Assist may fail to recognise other road users with their own lighting, or may recognise them too late.

In this, or in similar situations, the automatic main beam will not be deactivated or will be activated despite the presence of other road users.

- ▶ Always observe the traffic carefully and switch off the main beam in good time.

System limitations

Adaptive Highbeam Assist cannot take into account road, weather or traffic conditions.

Detection may be restricted if:

- Visibility is impaired, for example in fog, heavy rain or snow.
- There is dirt on the sensors or the sensors are obscured.

Adaptive Highbeam Assist is only an aid. You are responsible for adjusting the vehicle's lighting to the prevailing light, visibility and traffic conditions.

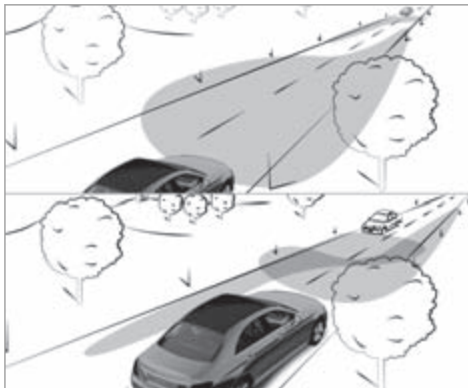

Adaptive Highbeam Assist switches automatically between:

- Dipped beam
- Main beam

At speeds above 30 km/h:

- If no other road users are detected, the main beam is automatically switched on.

The main beam switches off automatically:

- At speeds below 25 km/h.
- If other road users are detected.
- If street lighting is sufficient.

At speeds above approx. 50 km/h:

- The headlamp range of the dipped beam is regulated automatically based on the distance to other road users.

The system's optical sensor is located behind the windscreen near the overhead control panel.

Switching Adaptive Highbeam Assist on/off

- ▶ **To switch on:** turn the light switch to the **AUTO** position.
- ▶ Switch on the main beam using the combination switch. When the main beam is switched on automatically in the dark, the  indicator lamp in the multifunction display comes on.
- ▶ **To switch off:** switch off the main beam using the combination switch.

Adaptive Highbeam Assist Plus

Adaptive Highbeam Assist Plus function

⚠ WARNING Risk of accident despite Adaptive Highbeam Assist Plus

Adaptive Highbeam Assist Plus does not recognise the following road users:

- Road users without lights, e.g. pedestrians
- Road users with poor lighting, e.g. cyclists
- Road users whose lighting is obstructed, e.g. by a barrier

On very rare occasions, Adaptive Highbeam Assist Plus may fail to recognise other road users that have lights, or may recognise them too late.

In this, or in similar situations, the automatic main beam will not be deactivated or will be activated despite the presence of other road users.

▶ Always observe the traffic carefully and switch off the main beam in good time.

System limitations

Adaptive Highbeam Assist Plus cannot take into account road, weather or traffic conditions.

Detection may be restricted if:

- Visibility is impaired, for example in fog, heavy rain or snow.
- There is dirt on the sensors or the sensors are obscured.

Adaptive Highbeam Assist Plus is only an aid. You are responsible for adjusting the vehicle's lighting to the prevailing light, visibility and traffic conditions.

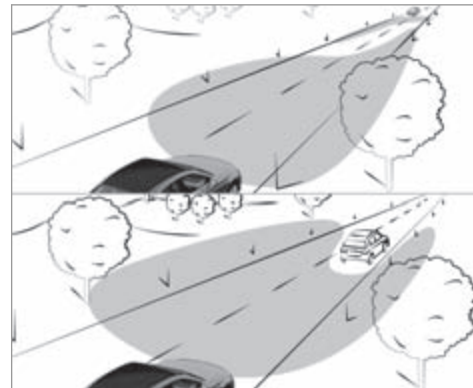

Adaptive Highbeam Assist Plus switches automatically between:

- Dipped beam
- Partial main beam
- Main beam

The partial main beam uses the main beam to shine past other road users rather than dazzling

them. The vehicle in front is illuminated by the dipped beam.

At speeds above 30 km/h:

- If no other road users are detected, the main beam is automatically switched on.
- If other road users are detected, the partial main beam is automatically switched on.

At speeds below 25 km/h or when there is sufficient street lighting:



- The partial main beam switches off automatically.
- The main beam switches off automatically.

At speeds above approx. 50 km/h:

- The headlamp range of the dipped beam is regulated automatically based on the distance to other road users.

The system's optical sensor is located behind the windscreen near the overhead control panel.

Switching Adaptive Highbeam Assist Plus on/off

- ▶ **To switch on:** turn the light switch to the  position.
- ▶ Switch on the main beam using the combination switch. When the main beam is switched on automatically in the dark, the  indicator lamp on the multifunction display comes on.
- ▶ **To switch off:** switch off the main beam using the combination switch.

Setting the dipped beam

Multimedia system:

- ↳ Vehicle ▶ Lights ▶ Dipped-beam headlamp conversion
- ▶ Select **Set for right-side traffic** or **Set for left-side traffic**.

Setting the exterior lighting switch-off delay time

Requirement:

- The light switch is in the  position.

Multimedia system:

- ↳ Vehicle ▶ Lights ▶ Exterior lighting delayed shut-off

If you switch on this function, the exterior lighting is switched on for a short time after the vehicle is switched off.

- ▶ Set a switch-off delay time.

Switching the locator lighting on/off

Multimedia system:

- ↳ Vehicle ▶ Lights ▶ Locator illumination

The exterior lighting remains lit for 40 seconds after the vehicle is unlocked. When you start the vehicle, the locator lighting is switched off and automatic driving lights are activated.





- ▶ Switch the function on or off.

Interior lighting

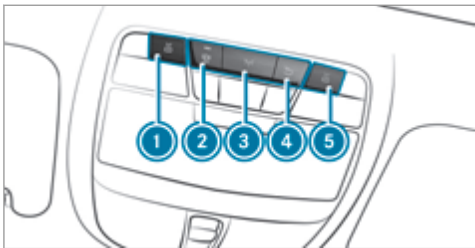
Adjusting the interior lighting

Front overhead control panel



- ①  Rear reading lamp
- ②  Automatic interior lighting control
- ③  Front interior lighting
- ④  Rear interior lighting
- ⑤  Front right reading lamp

▶ **To switch on or off:** press the ① - ⑤ button.

Control panel in the grab handle



- ①  Rear reading lamp

▶ **To switch on or off:** press the ① button.

Adjusting the ambient lighting

Multimedia system:

↳ Vehicle ▶ Lights

Setting the colour

- ▶ Select **Ambient lighting colour**.
- ▶ Select a colour.

Adjusting the brightness

- ▶ Select **Ambient lighting brightness**.
- ▶ **To set the brightness:** select the brightness value using the left-hand setting element.
- ▶ **To set the zone:** select the zone using the right-hand setting element.

Setting the interior lighting switch-off delay time

Multimedia system:

↳ Vehicle ▶ Lights ▶ Interior lighting delayed shut-off

- ▶ Set the switch-off delay time.

Changing bulbs (only for vehicles with halogen headlamps)

Notes on changing bulbs

⚠ WARNING Risk of burns from hot component parts whilst replacing a bulb

Bulbs, lamps and plugs can become very hot during operation.

When replacing a bulb, you could burn yourself on these component parts.

▶ Allow the component parts to cool down before replacing the bulb.

- Do not use a bulb if it has been dropped or if its glass has been scratched. The bulb may otherwise explode.
- Do not touch the glass bulb with your bare hands.
- Protect bulbs from moisture and do not allow bulbs to come into contact with liquids.

Overview of bulb types

The following bulbs can be replaced.

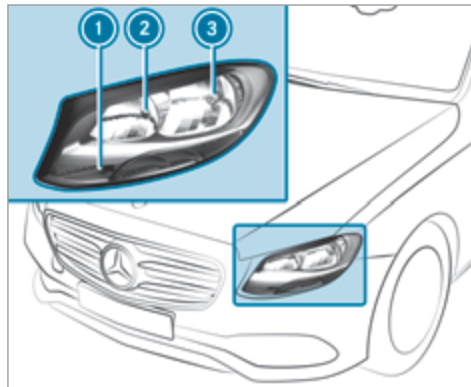

Halogen headlamps

- ① Turn signal light: PY 21 W
- ② Main beam: H7 55 W
- ③ Dipped beam: H7 55 W

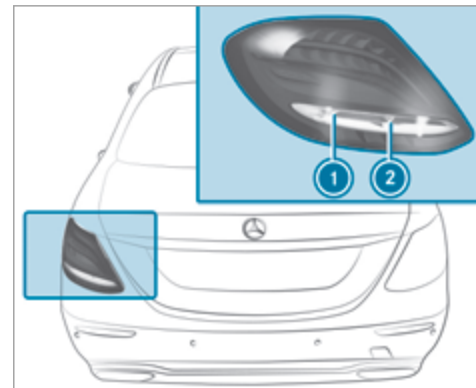

Tail lamps

- ① Turn signal light: PY 21 W
- ② Reversing light: W 16 W

Changing the front bulbs (vehicles with halogen headlamps)

Fitting/removing the cover on the front wheel arch

Requirements:

- The lighting system is switched off.
- The appropriate front wheel is turned inwards.

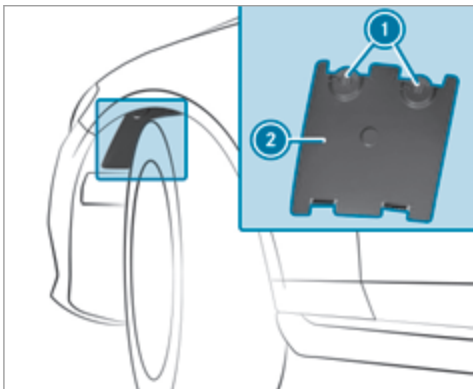

► **Removal (left-hand side of the vehicle):** using a screwdriver, turn rotating catches ① clockwise as far as they will go. Cover ② is released.

► **Removal (right-hand side of the vehicle):** using a screwdriver, turn rotating catches ① anti-clockwise as far as they will go. Cover ② is released.

► Remove cover ②.

► **To fit:** insert cover ② into the wheel arch liner.

- Left-hand side of the vehicle: using a screwdriver, turn rotating catches ① anti-clockwise as far as they will go.
- Right-hand side of the vehicle: using a screwdriver, turn rotating catches ① clockwise as far as they will go.

Cover ② is locked.

Replacing bulbs in the halogen headlamp

Requirements:

- **Main beam/dipped beam:** bulb, type H7 55 W.

- **Turn signal light:** bulb, type PY 21 W.
- The lighting system is switched off.
- The cover in the front wheel arch has been removed.
- The engine bonnet is open.

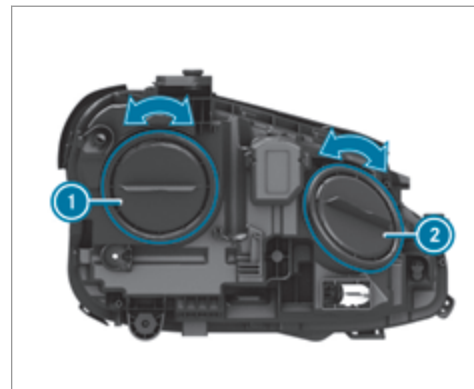

- ① Dipped beam
- ② Main beam/turn signal light

- ▶ Turn the relevant housing cover anti-clockwise and remove it.
- ▶ **Main beam/dipped beam:** turn the socket anti-clockwise and remove it.
- ▶ **Turn signal light:** turn the socket anti-clockwise, unlock and remove it.
- ▶ Pull the bulb out of the socket.
- ▶ Insert the new bulb into the socket so that the entire base of the bulb is resting on the bottom of the socket.
- ▶ Insert socket and turn it clockwise.
- ▶ Press on the housing cover and turn it clockwise.
- ▶ Replace the cover in the front wheel arch.

Changing the rear bulbs (vehicles with halogen headlamps)

Opening and closing the side trim panels in the boot



- ▶ **To open:** release right-hand or left-hand side trim panels ① at the side and remove.
- ▶ **To close:** reinsert side trim panel ①.

Replacing the tail lamp bulbs

Requirements:

- **Turn signal light:** bulb, type PY 21 W.
- **Reversing light:** bulb, type W 16 W.
- The lighting system is switched off.

- The side trim panel in the boot is open.

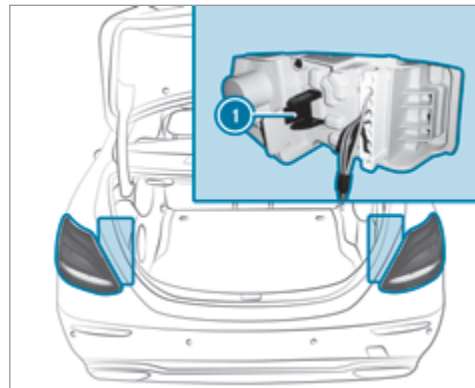

- ▶ Press the upper and lower catch on the plug together and remove the plug.
- ▶ Press tab ① outwards and remove the bulb mount.

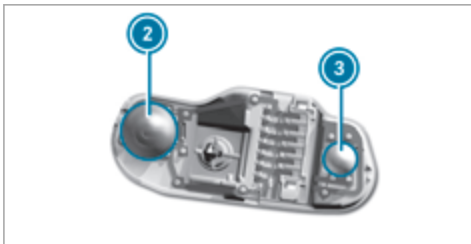

- ▶ **Turn signal light:** press bulb ② gently into the bulb mount, turn it anti-clockwise and remove it from the bulb mount.
- ▶ Insert the new bulb into the bulb mount and turn it clockwise.
- ▶ **Reversing light:** pull bulb ③ out of the bulb mount.
- ▶ Insert the new bulb into the bulb mount.
- ▶ Insert the bulb mount again.
- ▶ Insert the plug until the catch hooks engage audibly.
- ▶ Close the side trim panel.

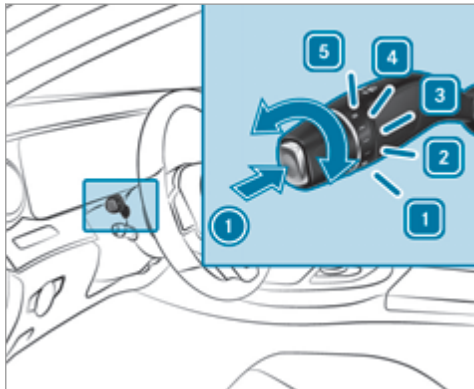

Windscreen wipers and windscreen washer system

Switching the windscreen wipers on/off



- ① 0 Windscreen wipers off
- ② ... Intermittent wiping, normal
- ③ Intermittent wiping, frequent

- ④ — Continuous wiping, slow
- ⑤ = Continuous wiping, fast

- ▶ Turn the combination switch to the correct position ① - ⑤.
- ▶ **Single wipe / washing:** push the button on the combination switch in the direction of arrow ①.
 -  Single wipe
 -  Wiping with washer fluid

Replacing the windscreen wiper blades

⚠ WARNING Risk of becoming trapped if the windscreen wipers are switched on while wiper blades are being replaced

If the windscreen wipers begin to move while you are changing the wiper blades, you can be trapped by the wiper arm.

- ▶ Always switch off the windscreen wipers and ignition before changing the wiper blades.

Moving the wiper arms to a vertical position

- ▶ Set the windscreen wipers to the  slow continuous wiping position on the combination switch.
- ▶ As soon as the wiper arms are vertical relative to the engine bonnet, switch off the ignition.

Removing the wiper blades

- ▶ Fold the wiper arms away from the windshield.

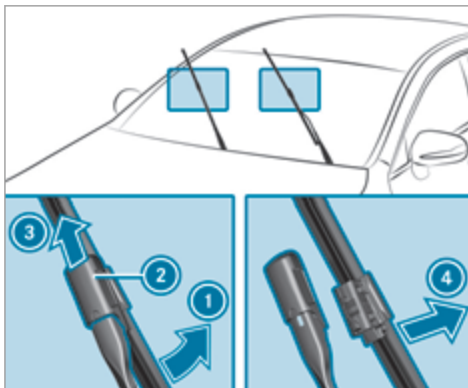

- ▶ Hold the wiper arm with one hand. With the other hand, turn the wiper blade in the direction of arrow ① away from the wiper arm to the stop.
- ▶ Slide catch ② in the direction of arrow ③ until it engages in the removal position.
- ▶ Remove the wiper blade in the direction of arrow ④ away from the wiper arm.

Fitting the wiper blades

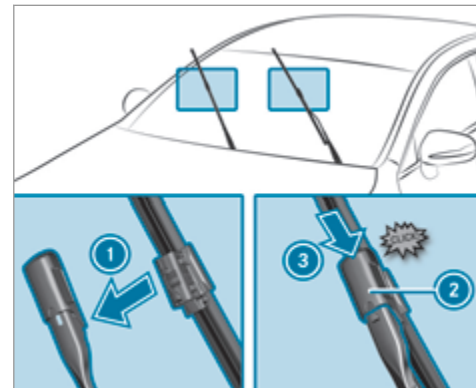

- ▶ Insert the new wiper blade into the wiper arm in the direction of arrow ①.
- ▶ Slide catch ② in the direction of arrow ③ until it engages in the locking position.
- ▶ Make sure that the wiper blade sits correctly.
- ▶ Fold the wiper arms back onto the windscreen.

Maintenance display

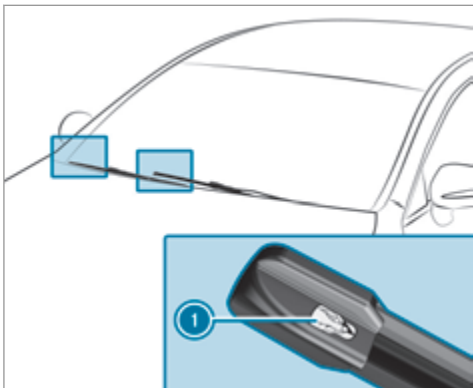

- ▶ Remove protective film ① of the maintenance display on the tip of the newly fitted wiper blades.

If the colour of the maintenance display changes from black to yellow, the wiper blades should be replaced.

- ① The duration of the colour change varies depending on the usage conditions.

Mirrors

Operating the outside mirrors

- ⚠ **WARNING** Risk of injury through adjusting vehicle settings while the vehicle is in motion

You could lose control of the vehicle in the following situations:

- if you adjust the driver's seat, the head restraints, the steering wheel or the mirror while the vehicle is in motion
 - if you fasten your seat belt while the vehicle is in motion
- ▶ Before starting the engine: adjust the driver's seat, the head restraints, the steering wheel or the mirror and fasten your seat belt.

- ⚠ **WARNING** Risk of accident due to misjudgement of distances when using the outside mirror

The outside mirrors reflect objects on a smaller scale. The objects in view are in fact closer than they appear.

As a result, you may misjudge the distance between you and the road user driving behind you, e.g. when changing lanes.

- ▶ Therefore, always look over your shoulder in order to ensure that you are aware of the actual distance between you and the road users driving behind you.

Folding the outside mirrors in/out

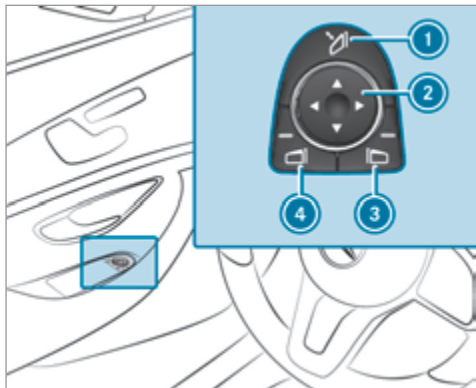

▶ Briefly press switch ①.

① If the battery has been disconnected or completely discharged, the outside mirrors must be reset. Only then will the automatic mirror folding function work properly.

Adjusting the outside mirrors

- ▶ Press the ③ or ④ buttons to select the outside mirror to be set.
- ▶ Press the ② button to set the position of the mirror glass.

Engaging the outside mirrors

- ▶ Vehicles without electrically folding outside mirrors: manually move the outside mirror into the correct position.
- ▶ Vehicles with electrically folding outside mirrors: press and hold button ①. You will hear a click and the mirror audibly engage in position. The outside mirror is set in the correct position.

Automatic anti-dazzle mirrors function

⚠ WARNING Risk of burns and poisoning due to the anti-dazzle mirror electrolyte

Electrolyte may escape if the glass in an automatic anti-dazzle mirror breaks.

The electrolyte is harmful and causes irritation. It must not come into contact with your skin, eyes, respiratory organs or clothing or be swallowed.

- ▶ If you come into contact with electrolyte, observe the following:
 - Rinse the electrolyte from your skin and seek medical attention immediately.
 - If electrolyte comes into contact with your eyes, rinse them thoroughly with clean water and seek medical attention immediately.
 - If the electrolyte is swallowed, immediately rinse your mouth out thoroughly. Do not induce vomiting. Seek medical attention immediately.
 - Immediately change out of clothing which has come into contact with electrolyte.
 - If an allergic reaction occurs, seek medical attention immediately.

The inside rear-view mirror and the outside mirror on the driver's side automatically go into anti-dazzle mode if light from a headlamp hits the inside rear-view mirror.

System limitations

The system does not go into anti-dazzle mode in the following situations:

- the engine is switched off.
- reverse gear is engaged
- the interior lighting is switched on

Function of the passenger outside mirror parking position

 The parking position is available only in vehicles with a memory function.

The parking position makes parking easier.

The passenger outside mirror tilts downwards and shows the rear wheel on the front passenger side in the following situations:

- the parking position is stored (→ page 144)
- the passenger mirror is selected
- reverse gear is engaged



The passenger outside mirror moves back to its original position in the following situations:

- if you shift the transmission to another transmission position
- at speeds greater than 15 km/h
- if you press the button for the outside mirror on the driver's side

Storing the parking position of the passenger outside mirror using reverse gear

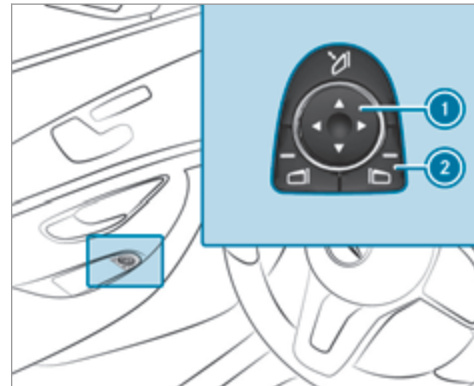
Storing



- ▶ Select the passenger outside mirror using button .
- ▶ Engage reverse gear.
- ▶ Move the passenger outside mirror into the desired parking position using button .

Calling up

- ▶ Select the passenger outside mirror using button ②.
- ▶ Engage reverse gear. The passenger outside mirror moves to the stored parking position.

Activating/deactivating the automatic mirror folding function

Multimedia system:

➔ Vehicle ▶ Vehicle settings ▶ Automatic mirror-folding function

- ▶ Activate or deactivate the function.

Operating the sun visors

Using the single sun visor

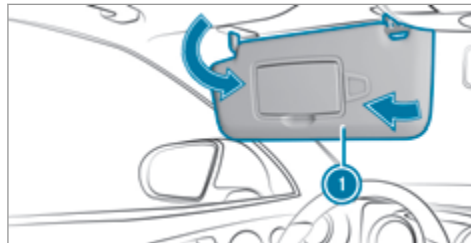

- ▶ **Glare from the front:** fold sun visor ① down.
- ▶ **Glare from the side:** swing sun visor ① to the side.

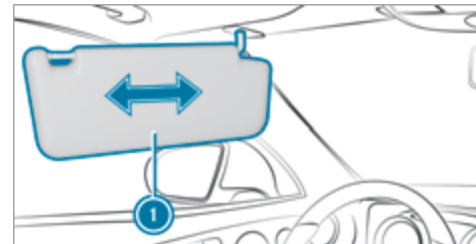

- ▶ Vehicles with an extendable sun visor: slide sun visor ① horizontally as required.

Using the additional sun visor

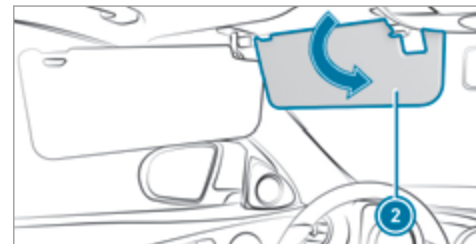

- ▶ Vehicles with an additional sun visor: fold additional sun visor ② down.

Infrared reflective windscreen

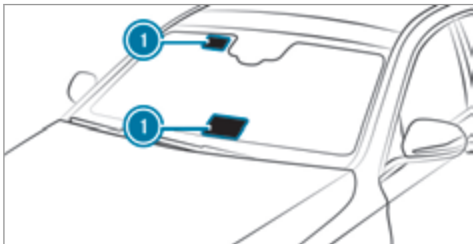

The infrared reflective windscreen is coated and prevents an excessive build-up of heat in the vehicle interior.

The coating shields the vehicle interior against radio waves up into the gigahertz range.

Radio-controlled equipment, such as toll systems, can only be mounted on areas of the windscreen which are permeable to radio waves ①.

Areas permeable to radio waves ① are best visible from outside the vehicle when the windscreen is illuminated using an external light source.

Overview of climate control systems

Notes on climate control

Vehicles with THERMOTRONIC automatic climate control: an interior air filter must always be used so that the air conditioning system, the pollution level monitoring and the air filtering function work correctly. Make sure that the filter is installed correctly and the filter housing in the engine compartment is closed correctly using the cap and always tightly sealed when in operation. Use filters recommended and approved by Mercedes-Benz. Always have service work carried out at a qualified specialist workshop.

THERMATIC control panel overview

The indicator lamps in the buttons indicate that the current function is activated.

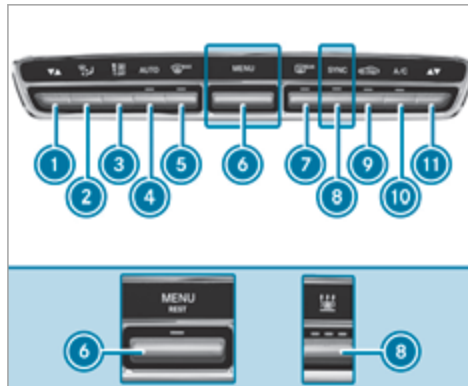

- ① To set the driver's side temperature
- ② To set the air distribution
- ③ To set the airflow or switch off climate control
- ④ **AUTO** To set climate control to automatic mode (→ page 149)
- ⑤ To demist the windscreen

- ⑥ Vehicles without a stationary heater: **MENU** to call up the air conditioning menu
Vehicles with a stationary heater: **MENU REST** to call up the air conditioning menu, to switch the residual heat on/off (→ page 151)
- ⑦ To switch the rear window heater on/off
- ⑧ Vehicles without a stationary heater: **SYNC** to switch the synchronisation on/off (→ page 150)
Vehicles with a stationary heater: to switch the stationary heater on/off (→ page 153)
- ⑨ To switch air-recirculation mode on/off (→ page 150)
- ⑩ **A/C** To switch the A/C function on/off (→ page 149)
- ⑪ To set the front passenger side temperature

THERMOTRONIC control panel overview

The indicator lamps in the buttons indicate that the current function is activated.

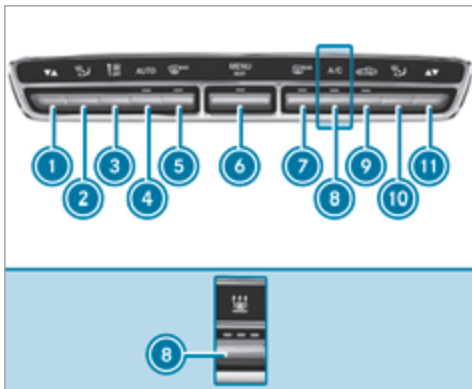

- ① To set the driver's side temperature
- ② To set the driver's side air distribution
- ③ To set the airflow or switch off climate control
- ④ **AUTO** To set climate control to automatic mode (→ page 149)
- ⑤ To demist the windscreen
- ⑥ **MENU REST** To call up the air conditioning menu

To switch the residual heat on or off (→ page 151)

- ⑦ To switch the rear window heater on/off
- ⑧ Vehicles without a stationary heater: to switch the A/C function on/off (→ page 149)
Vehicles with a stationary heater: to switch the stationary heater on/off (→ page 153)
- ⑨ To switch air-recirculation mode on/off (→ page 150)
- ⑩ To set the front passenger side air distribution
- ⑪ To set the front passenger side temperature

Rear operating unit

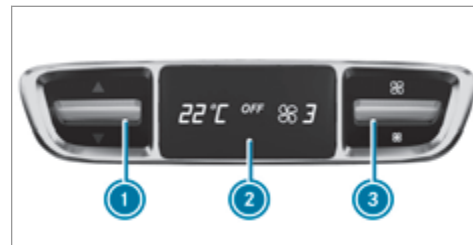

- ① To set the temperature
- ② Display
- ③ To set the airflow

Operating the climate control system

Switching climate control on/off

- ▶ **To switch on:** set the airflow to level 1 or higher using the button.
- ▶ **To switch off:** set the airflow to level 0 using the button.

- i** When the climate control is switched off, the windows can mist up faster. Only switch off the climate control briefly.

Activating/deactivating the A/C function via the control panel

The A/C function cools, heats and dehumidifies the interior air in the vehicle.

- ▶ Press button .

Deactivate the A/C function only briefly otherwise the windows can mist up more quickly.

Condensation may drip from the underside of the vehicle when cooling mode is active. This is not a sign that there is a malfunction.

Activating/deactivating the A/C function using the multimedia system

Multimedia system:





The A/C function heats, cools and dehumidifies the vehicle's interior air.

- ▶ **To call up the climate control bar:** navigate down until the climate control bar is active.
- ▶ Call up the **A/C on/off** air conditioning menu.
- ▶ Select **A/C**.
- ▶ Switch the function on or off .
- i** The climate control bar can be called up from any menu.

Setting climate control to automatic mode

In automatic mode, the set temperature is controlled and maintained at a constant level by the air supply.

- ▶ Press the  button.
- ▶ **To switch to manual mode:** press the  or  button.

Climate style

Climate style function

In automatic mode, you can select the following climate style settings for the driver's and front passenger areas:

- **FOCUS:** high airflow, slightly cooler setting
- **MEDIUM:** medium airflow, standard setting
- **DIFFUSE:** low airflow, slightly warmer and draught-free setting

Setting the climate style

Requirements:

- THERMOTRONIC automatic climate control is fitted.
- The  button has been pressed.

Multimedia system:











- ▶ **To call up the climate control bar:** navigate down until the climate control bar is active.
- ▶ Call up the **A/C on/off** air conditioning menu.

- ▶ Select **Climate mode**.
- ▶ Select **FOCUS**, **MEDIUM** or **DIFFUSE**.

 The climate control bar can be called up from any menu.

Overview of air distribution settings

The symbols in the display indicate which vents the airflow is being directed through:

-  demister vents
-  centre and side air vents
-  footwell vents
-  centre, side and footwell vents
-  defroster and footwell vents
-  all vents
-  defroster, middle and side air vents
-  automatic air distribution

Activating/deactivating the climate control synchronisation function via the control panel

Climate control can be set centrally using the synchronisation function. The temperature and air distribution setting for the driver's side is adopted automatically for the front passenger side.

- ▶ Press button .

The synchronisation function is deactivated if the settings for one of the other climate zones are changed.

Activating/deactivating the climate control synchronisation function using the multimedia system

Multimedia system:



- ↳  **Vehicle**

Climate control can be set centrally using the synchronisation function. The temperature setting is automatically adopted for all climate zones.

- ▶ **To call up the climate control bar:** navigate down until the climate control bar is active.
 - ▶ Call up the **A/C on/off** climate control menu.
 - ▶ Select **SYNC**.
 - ▶ Switch the function on or off .
-  The climate control bar can be called up from any menu.

Demisting the windows

Windows misted up on the inside

- ▶ Press the  button.
- ▶ If the windows continue to mist up: press the  button.

Windows misted up on the outside

- ▶ Switch on the windscreen wipers.
- ▶ Press the  button.

Switching air-recirculation mode on/off

- ▶ Press the  button. The interior air will be recirculated.

Air-recirculation mode is switched off automatically.

- ❗ If air-recirculation mode is switched on, the windows may mist up more quickly. Switch on air-recirculation mode only briefly.

Switching the residual heat on/off

Requirements:

- The vehicle is parked.

It is possible to make use of the residual heat from the engine to continue heating or ventilating the front compartment of the vehicle for approximately 30 minutes.

- ▶ **To switch on:** press the  button.

Residual heat is switched off automatically.

Activating and deactivating ionisation

Multimedia system:

- ↳ Vehicle

Ionisation cleans and refreshes the interior air of the vehicle. The ionisation of the interior air is odourless.

- ▶ **To call up the climate control bar:** navigate down until the climate control bar is active.
- ▶ Call up the [A/C on/off](#) air conditioning menu.
- ▶ Select [Ionisation](#).
- ▶ Activate or deactivate the function.

- ❗ The climate control bar can be called up from any menu.

Fragrance system

Activating or deactivating the fragrance system

Requirements:

- Automatic climate control is activated.
- The glove compartment is closed.

Multimedia system:

- ↳ Vehicle

The fragrance system distributes a pleasant fragrance throughout the vehicle interior from a flacon located in the glove compartment.

- ▶ **To call up the climate control bar:** navigate down until the climate control bar is active.
- ▶ Call up the [A/C on/off](#) air conditioning menu.
- ▶ Select [Air freshener](#).
- ▶ Activate or deactivate fragrancing.
- ▶ Adjust the intensity.

- ❗ The climate control bar can be called up from any menu.

Inserting or removing the flacon of the fragrance system

⚠ WARNING Risk of injury from liquid perfume

If children open the flacon, they could drink the liquid perfume or it could come into contact with their eyes.

- ▶ Consult a doctor immediately if liquid perfume has been drunk.
- ▶ If liquid perfume comes into contact with your eyes or skin, rinse your eyes with clean water.
- ▶ If symptoms continue, consult a doctor.



ENVIRONMENTAL NOTE Environmental damage due to improper disposal of full flacons



Full flacons must not be disposed of with household waste.



Full flacons must be taken to a harmful substance collection point.

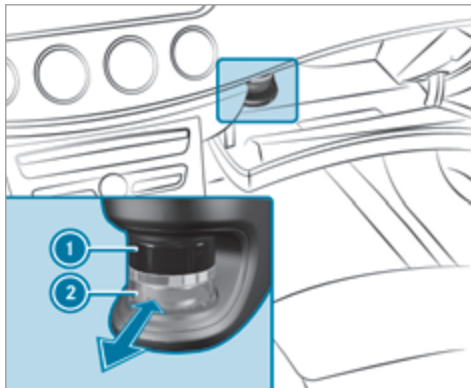

- ① Cap
- ② Flacon

- ▶ **To insert:** slide the flacon into the holder as far as it will go.
- ▶ **To remove:** pull out the flacon.

If you do not use genuine Mercedes-Benz interior perfumes, observe the manufacturers' safety notices on the perfume packaging.

Dispose of the genuine Mercedes-Benz interior perfume flacon when it is empty and do not refill it.

Refillable flacon

- ▶ Unscrew the cap of the empty flacon.
- ▶ Fill the flacon with a maximum of 15 ml.
- ▶ Screw the cap back on to the flacon.

Always refill the empty refillable flacon with the same perfume. Observe the separate information sheet attached to the flacon.

Information on the windscreen heater

The windscreen heater is switched on automatically if the  button is activated.

After the vehicle is started the windscreen heater is switched on automatically as needed.

Stationary heater/ventilation

Function of the stationary heater/stationary ventilation

- The air in the vehicle interior is heated or ventilated to the set temperature.
- The air in the vehicle interior cannot be cooled down to temperatures below the outside temperature.
- If the outside temperature changes, ventilation mode automatically switches to heating mode or from heating mode to ventilation mode.

The stationary heater and the exhaust gas outlet are situated at the right-hand front wheel.

Switching the stationary heater/stationary ventilation on/off via the operating unit

⚠ DANGER Risk of fatal injury due to poisonous exhaust gases

If the tailpipe is blocked or sufficient ventilation is not possible, poisonous exhaust gases such as carbon monoxide may enter the vehi-

cle. This is the case in enclosed spaces or if the vehicle gets stuck in snow, for example.

- ▶ Always switch the stationary heater off in enclosed spaces without an air extraction systems, e.g. in garages.
- ▶ Keep the tailpipe and the area around the vehicle free from snow when the engine or the stationary heater are running.
- ▶ Open a window on the windward side of the vehicle to ensure an adequate supply of fresh air.

⚠ WARNING Risk of fire due to hot stationary heater components

When the stationary heater is switched on, parts of the vehicle can become very hot, e.g. the stationary heater exhaust system.

Flammable materials such as leaves, grass or twigs may ignite if they come into contact with:

- hot parts of the stationary heater exhaust system
 - the exhaust gas itself
- ▶ When the stationary heater is switched on, make sure that:
- hot vehicle parts do not come into contact with flammable materials.
 - the exhaust gas can flow out of the stationary heater tailpipe unhindered.
 - the exhaust gas does not come into contact with flammable materials.

! NOTE Battery discharge caused by stationary heater or stationary ventilation operation

Operating the stationary heater or stationary ventilation drains the battery.

- ▶ After heating or ventilating the vehicle twice, drive for a longer period of time.

Requirements:

- The fuel tank is filled to at least reserve fuel level.

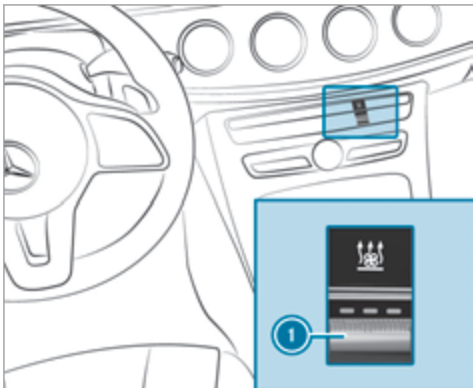

- ▶ Set the desired temperature using the ▼▲ button.

- ▶ Press button ①.
The red or blue indicator lamp in button ① lights up or goes out.

Indicator lamp colours:

- **blue:** stationary ventilation is switched on
- **red:** stationary heater is switched on
- **yellow:** departure time is preselected

The stationary heater/stationary ventilation switches off automatically after 50 minutes.

Operation using the app (for EU countries only): the stationary heater/ventilation can also be operated via the Mercedes me connect app. Further information can be found in the separate Owner's Manual under http://manuals.daimler.com/baix/cars/connectme/de_DE/index.html.

Setting the stationary heater/stationary ventilation using the multimedia system

Multimedia system:



You can pre-set three departure times for automatic activation of the stationary heater.

- ▶ **To call up the climate control bar:** navigate down until the climate control bar is active.
- ▶ Call up the **A/C on/off** air conditioning menu.
- ▶ Select **Auxiliary heating**.
- ▶ Select an option.
- ① The climate control bar can be called up from any menu.

Setting the stationary heater/stationary ventilation via remote control**Requirements:**

- The fuel tank is filled to at least reserve fuel level.

Switching on immediately



- ▶ Press and hold the **ON** button.

Setting the departure time

- ▶ Briefly press the **ON** button.
- ▶ Press the **<** or **>** button repeatedly until the time to be changed appears in the display.

- ▶ Press the **ON** and **OFF** buttons simultaneously. The symbol in the remote control display flashes.
- ▶ Press the **<** and **>** buttons to set the desired departure time.
- ▶ Press the **ON** and **OFF** buttons simultaneously. The new departure time is stored.

Up to three departure times can be stored.

- ▶ **To activate the departure time:** select the desired departure time and press and hold the **ON** button. The symbol, the departure time and, depending on the selected departure time, the letter **A**, **B** or **C** appear in the display.
- ▶ **To deactivate the departure time:** select the desired departure time and press and hold the **OFF** button. **OFF** appears in the display.
- ▶ **To check the status of the stationary heater:** briefly press the **ON** button.

Switching off immediately

- ▶ Press and hold the **OFF** button.

Overview of the remote control displays (stationary heater/stationary ventilation)

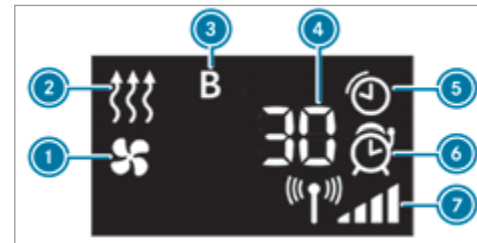

- 1 Stationary ventilation switched on
- 2 Stationary heater switched on
- 3 Selected departure time
- 4 Remaining time for the stationary heater/stationary ventilation (in minutes)
- 5 Stationary heater/stationary ventilation active
- 6 Departure time activated
- 7 Signal strength

Further possible displays:

- **Time:** activated departure time.
- **Zero minutes:** the running time for the stationary heater is increased, as the engine has not yet reached operating temperature when it is started.
- **OFF:** the stationary heater/stationary ventilation is switched off.

Replacing the remote control battery (stationary heater)

⚠ DANGER Serious damage to health caused by swallowing batteries

Batteries contain toxic and corrosive substances. Swallowing batteries may cause serious damage to health.

There is a risk of fatal injury.

- ▶ Keep batteries out of the reach of children.

- ▶ If batteries are swallowed, seek medical attention immediately.

♻ ENVIRONMENTAL NOTE Environmental damage due to improper disposal of batteries



Batteries contain toxic and corrosive substances.



Take discharged batteries to a qualified specialist workshop or to a collection point for used batteries.

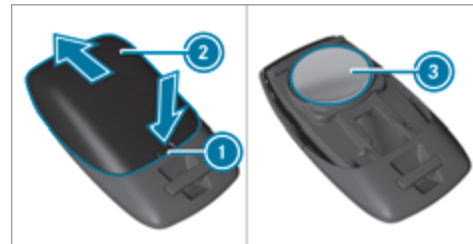

Requirements:

- a CR2450 lithium battery



- ▶ Press a pointed object into recess ①.
- ▶ Slide battery cover ② backwards in the direction of the arrow.
- ▶ Insert new battery ③ with the lettering facing upwards.
- ▶ Slide battery cover ② in the opposite direction to the arrow onto the remote control until the battery cover engages.

Problems with the remote control for the stationary heater/stationary ventilation

Problem	Possible causes/consequences and ► Solutions
FAIL 	<p>The signal transmission between the transmitter and the vehicle is faulty.</p> <p>► Change your position in relation to the vehicle, moving closer if necessary.</p>
FAIL	<p>The starter battery is not sufficiently charged.</p> <p>► Charge the starter battery.</p> <p>The fuel tank content is below the reserve fuel level.</p> <p>► Refuel at the nearest filling station.</p>
FAIL 	<p>The stationary heater is malfunctioning.</p> <p>► Have the stationary heater checked at a qualified specialist workshop.</p>

Air vents

Adjusting the front air vents

⚠ WARNING - Risk of burns/frostbite due to not maintaining a sufficient distance to the air vents

Very hot or very cold air can flow from the air vents.

This could result in burns or frostbite in the immediate vicinity of the air vents.

- Always ensure that all vehicle occupants maintain a sufficient distance to the air vents.
- If necessary, redirect the airflow to another area of the vehicle interior.



▶ **To open or close:** turn controller ② to the left or right as far as it will go.

▶ **To adjust the air direction:** hold air vent ① in the centre and move it up or down or to the left or right.

Adjusting the rear air vents

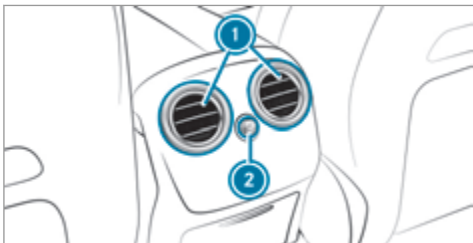

▶ **To open or close:** turn controller ② to the left or right as far as it will go.

▶ **To adjust the air direction:** hold rear air vent ① in the centre and move it up or down or to the left or right.

Opening/closing the air vent in the glove box

1 NOTE Damage to temperature-sensitive objects in the glove box

Temperature-sensitive objects stored in the glove box may be damaged by the air vent located inside the glove compartment.

- ▶ Close the air vent when you heat the vehicle.
- ▶ At high outside temperatures, open the air vent and switch on the A/C function.

Requirements:

- Automatic climate control is activated.

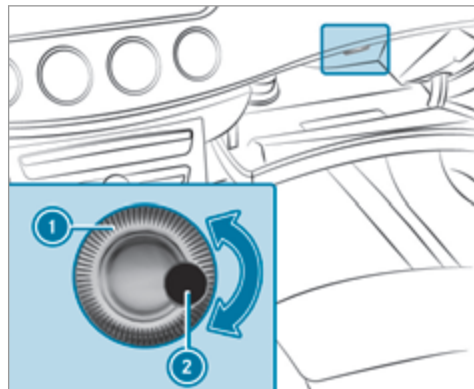

① Air vent controller

② Air vent

▶ **To open or close:** turn controller ① to the left or right.

Driving

Notes on Mercedes-AMG vehicles

Observe the notes on the following topics in the Supplement. Otherwise, you may fail to recognise dangers.

- Rear axle locking differential
- AMG Performance exhaust system
- AMG ceramic high-performance composite brake system
- RACE START
- DRIFT MODE
- AMG RIDE CONTROL

Switching on the power supply or ignition using the Start/Stop button

⚠ WARNING Risk of accident and injury due to children left unattended in the vehicle

If children are left unattended in the vehicle, they could:

- Open doors, thereby endangering other persons or road users.
- Get out of the vehicle and be hit by oncoming traffic.
- Operate vehicle equipment and become trapped, for example.

Moreover, children could also set the vehicle in motion by, for example:

- Releasing the parking brake.
- Shifting the automatic transmission out of park position **P** or shifting manual transmission into idle position.
- Starting the engine.

- ▶ Never leave children and animals unattended in the vehicle.
- ▶ When leaving the vehicle, always take the key with you and lock the vehicle. This also applies to mobile phones if the "Digital Car Key in the smartphone" function is activated via the Mercedes me connect web app.
- ▶ Keep the vehicle key out of reach of children. This also applies to mobile phones if the "Digital Car Key in the smartphone" function is activated via the Mercedes me connect web app.

⚠ WARNING Risk of exhaust gas poisoning

Combustion engines emit poisonous exhaust gases such as carbon monoxide. Inhaling these exhaust gases causes poisoning.

- ▶ Never leave the engine running in an enclosed space without sufficient ventilation.

⚠ WARNING Risk of fire caused by flammable material on the exhaust system

Flammable materials brought in by either animals or environmental influences may ignite if they come into contact with hot parts of the engine or exhaust system.

- ▶ Therefore, check regularly that there are no flammable materials in the engine compartment or on the exhaust system.

Requirements:

- the key is located in the vehicle and the key battery is not discharged.
- or, if the "Digital Vehicle Key" function is activated via the Mercedes me connect web app: the mobile phone is in the marked space (→ page 161).

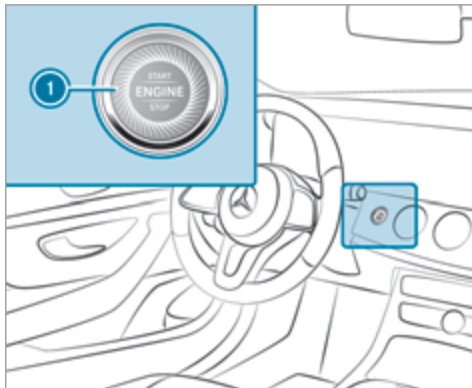

- ▶ **To switch on the power supply:** press button ① once. You can activate the windscreen wiper, for example.

The power supply is switched off again if the following conditions are met:

- you open the driver's door.
- you press button ① twice.

- ▶ **To switch on the ignition:** press button ① twice. The indicator lamps in the instrument cluster light up.

The ignition is switched off again if one of the following conditions is met:

- you do not start the vehicle within 15 minutes.

Vehicles with automatic transmission: the transmission is in position **P**.

or

The electric parking brake is applied.

- you press button ① once.

Starting the vehicle

Starting the vehicle with the start/stop button

Requirements:

- the key is located in the vehicle and the key battery is not discharged.
- or, if the "Digital Vehicle Key" function is activated via the Mercedes me connect web app:

the mobile phone is in the marked space (→ page 161).

- ▶ **Vehicles with manual transmission:** depress the clutch pedal.
- ▶ **Vehicles with automatic transmission:** shift the transmission to position **P** or **N**.
- ▶ Depress the brake pedal and push button **1** once.
- ▶ If the vehicle does not start: switch off non-essential consumers and press button **1** once.
- ▶ If the vehicle still does not start and the **Place the key in the marked space** See **Owner's Manual** display message also appears in the multifunction display: start the vehicle in emergency operation mode.

You can switch off the engine while driving by pressing button **1** for about three seconds. Be sure to observe the safety notes under "Driving instructions".

Starting a vehicle using a mobile phone

Requirements:

- the vehicle is equipped with the "Digital Car Key" function.
- the "Digital Car Key" function is activated via the Mercedes me connect web app: <http://www.mercedes.me>.
- suitable mobile phone with NFC aerial (Near Field Communication) and Secure Element.
- **sufficient charge level of the mobile phone.** On some mobile phones, the function is also available when the battery is discharged.

- i** You can check the suitability of your mobile phone by entering the phone number at <http://www.mercedes.me>. Information about suitable mobile phones can be obtained from your Mercedes-Benz service centre or at <http://www.mercedes-benz.com/connect>.
- i** Mercedes-Benz recommends that you carry the emergency key in case of function restrictions.

- i** The function is only available in combination with Mercedes me connect and only in certain countries.
 - i** Protective cases around the mobile phone can impair the functionality.
- ▶ Make sure that the charge level of the mobile phone is sufficient. If necessary, charge the mobile phone before starting the journey.

Starting the vehicle for the first time after activating the function

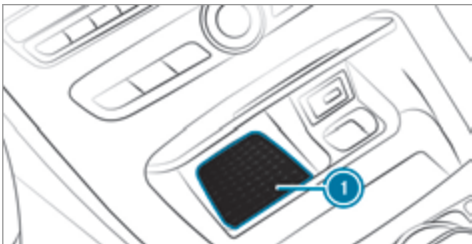

- ▶ Make sure that there is a valid vehicle key in the vehicle.

- ▶ Place the mobile phone in marked space ① so that the NFC aerial areas touch each other.
- ▶ Depress the brake pedal and start the vehicle using the start/stop button.
- ⓘ The key is not needed for any further starts.

Any further starts

- ▶ Place the mobile phone in marked space ① so that the NFC aerial areas touch each other, and leave it there while driving.
- ▶ Depress the brake pedal and start the vehicle using the start/stop button.

The "Digital Vehicle Key" service can be deactivated in Mercedes me connect at <http://www.mercedes.me>. The function is then deactivated in the smartphone via an online connection. If connection to the Internet is not possible, e.g. after the mobile phone has been stolen, the key function can be deactivated at a Mercedes-Benz Service Centre.

Starting the vehicle in emergency operation mode

If the vehicle does not start and the [Place the key in the marked space](#) See Owner's Manual display message appears in the multifunction display, you can start the vehicle in emergency operation mode.



- ▶ Ensure that the marked space ② is empty.
 - ▶ Remove key ① from the key ring.
 - ▶ Lay the key ① in the marked space ②. The vehicle will start after a short while.
- If you remove the key ① from the marked space ②, the engine starts again. For further vehicle starts, however, key ① must be

located in the marked space ② during the entire journey.

- ▶ Have the key ① checked at a qualified specialist workshop.

If the vehicle does not start:

- ▶ leave the key ① in the marked space ②.
- ▶ **Vehicles with manual transmission:** depress the clutch pedal.
- ▶ **Vehicles with automatic transmission:** depress the brake pedal.
- ▶ Start the vehicle using the start/stop button.
- ⓘ You can also switch on the power supply or the ignition with the start/stop button.

Starting the vehicle via Remote Online services

Cooling or heating the vehicle interior before starting the journey

- ⓘ This function is not available in all countries.
- If you start the vehicle via your smartphone, the previously selected air conditioning setting is active.

Ensure the following before starting the engine:

- the legal stipulations in the area where your vehicle is parked allow engine starting via smartphone.
- it is safe to start and run the engine where your vehicle is parked.
- the fuel tank is sufficiently filled.
- the starter battery is sufficiently charged.

 You can also set the temperature with your smartphone. Information on Mercedes me connect and other services: <http://www.mercedes.me>

Charging the battery before commencing your journey

-  This function is not available in all countries.
- If the vehicle battery is discharged, you receive a message on your smartphone.
- You can then start the vehicle with the smartphone to charge the battery.
- The vehicle is automatically switched off after ten minutes.

Ensure the following before starting the engine:

- the legal stipulations in the area where your vehicle is parked allow engine starting via smartphone.
- it is safe to start and run the engine where your vehicle is parked.
- the fuel tank is sufficiently filled.

Starting the vehicle

 **WARNING** Risk of crushing or entrapment due to unintentional starting of the engine

Limbs could be crushed or trapped if the engine is started unintentionally during service or maintenance work.

 Always secure the engine against unintentional starting before carrying out maintenance or repair work.

Requirements:

- park position **P** is selected.
- the anti-theft alarm system is not activated.
- the panic alarm is not activated.

- the hazard warning lamps are switched off.
- the bonnet is closed.
- the doors are closed and locked.
- the windows and sliding sunroof are closed.

 Start the vehicle using the smartphone:

- after every vehicle start, the engine runs for ten minutes.

- you can carry out a maximum of two consecutive starting attempts.
- you can stop the vehicle again at any time.
- further information can be found in the smartphone app.

Securing the engine against starting before carrying out maintenance or repair work:

 switch on the hazard warning lamps.

or

 unlock the doors.

or

 open a side window or the sliding sunroof.

Running-in notes

Mercedes-AMG vehicles: observe the notes in the Supplement. Otherwise, you may fail to recognise dangers.

To preserve the engine during the first 1,500 km:

- drive at varying road speeds and engine speeds.
- drive in drive program **C** or **E**.
- change gear before the rev counter needle is $\frac{2}{3}$ of the way to the red area of the rev counter.
- do not shift down a gear manually in order to brake.
- avoid overstraining the vehicle, e.g. driving at full throttle.
- **vehicles with automatic transmission:** do not depress the accelerator pedal beyond the pressure point (kickdown).
- only increase the engine speed gradually and accelerate the vehicle to full speed after 1,500 km.

This also applies when the engine or parts of the drivetrain have been replaced.

Please also observe the following running-in notes:

- In certain driving and driving safety systems, the sensors adjust automatically while a certain distance is driven after the vehicle has been delivered or after repairs. Full system effectiveness is not achieved until the end of this teach-in process.
- Brake linings, brake discs and tyres that are either new or have been replaced only achieve optimum braking effect and grip after several hundred kilometres of driving. Compensate for the reduced braking effect by applying greater force to the brake pedal.

Notes on driving

⚠ WARNING Risk of accident due to objects in the driver's footwell

Objects in the driver's footwell may impede pedal travel or block a depressed pedal.

This jeopardises the operating and road safety of the vehicle.

- ▶ Stow all objects in the vehicle securely so that they cannot get into the driver's footwell.
- ▶ Always fit the floor mats securely and as prescribed in order to ensure that there is always sufficient room for the pedals.
- ▶ Do not use loose floor mats and do not place floor mats on top of one another.

⚠ WARNING Risk of accident due to unsuitable footwear

Operating the pedals may be impaired by wearing unsuitable footwear, e.g.:

- platform shoes
- high-heeled shoes
- slippers
- ▶ Always wear suitable footwear when driving so that you can operate the pedals safely.

⚠ WARNING Risk of accident if the ignition is switched off while driving

If you switch off the ignition while driving, functions relevant to safety are restricted or no longer available. This may effect, for example, the power steering system and the brake force boosting.

You will then need to use considerably more force to steer and brake.

- ▶ Do not switch off the ignition while driving.

⚠ WARNING Risk of exhaust gas poisoning

Combustion engines emit poisonous exhaust gases such as carbon monoxide. Inhaling these exhaust gases causes poisoning.

- ▶ Never leave the engine running in an enclosed space without sufficient ventilation.

⚠ WARNING Risk of skidding and of an accident due to shifting down on slippery road surfaces

If you shift down on slippery road surfaces to increase the engine braking effect, the drive wheels may lose traction.

- ▶ Do not shift down on slippery road surfaces to increase the engine braking effect.

⚠ DANGER Risk of fatal injuries due to poisonous exhaust gases

If the tailpipe is blocked or sufficient ventilation is not possible, poisonous exhaust gases such as carbon monoxide may enter the vehicle. This is the case, for example, if the vehicle is stuck in snow.

- ▶ When the engine or the stationary heater are running, keep the tailpipe and the area around the vehicle clear of snow.

- ▶ Open a window on the side of the vehicle facing the wind to ensure an adequate supply of fresh air.

⚠ WARNING Risk of accident due to the brake system overheating

If you leave your foot on the brake pedal when driving, the brake system may overheat.

This increases the braking distance and the brake system may even fail.

- ▶ Never use the brake pedal as a footrest.
- ▶ Do not depress the brake pedal and the accelerator pedal at the same time while driving.

! NOTE Causing wear to the brake linings by permanently depressing the brake pedal

- ▶ Do not permanently depress the brake pedal while driving.

- ▶ To use braking effect of the engine, shift to a lower gear in good time.

! **NOTE** Damage to the drivetrain and engine when pulling away

- ▶ Do not warm up the engine when stationary. Pull away immediately.
- ▶ Avoid high engine speeds and full throttle until the engine has reached its operating temperature.
- ▶ Do not allow the wheels to spin.

! **NOTE** Damage to the catalytic converter due to non-combusted fuel

The engine is not running smoothly and is misfiring.

Non-combusted fuel may get into the catalytic converter.

- ▶ Only depress the accelerator pedal slightly.
- ▶ Have the cause rectified immediately at a qualified specialist workshop.

Limited braking effect on salt-treated roads:

- due to salt build-up on the brake discs and brake lining, the braking distance can increase considerably or result in braking only on one side.
- maintain a much greater safe distance to the vehicle in front.

To prevent salt build-up:

- brake occasionally while paying attention to the traffic conditions.
- carefully depress the brake pedal at the end of the journey and when starting the next journey.

ECO start/stop function



Operating the ECO start/stop function

Vehicles without a 48 V electrical system (EQ Boost technology)

Mercedes-AMG vehicles: observe the notes in the Supplement. Otherwise, you may fail to recognise dangers.

The engine is automatically switched off if the following conditions are met:

- **Vehicles with manual transmission:** you brake the vehicle, shift into neutral **N** when travelling at a low speed and then release the clutch pedal.
- **Vehicles with automatic transmission:** you brake the vehicle to a standstill in transmission position **D** or **N**.
- all vehicle conditions for an automatic engine stop are met.

The  symbol appears in the multifunction display when the vehicle is stationary. If not all the vehicle conditions are met, the  symbol appears in the multifunction display.

The engine is restarted automatically if:

- **Vehicles with manual transmission:** you depress the clutch pedal.
- **Vehicles with automatic transmission:** in transmission position **D**, you release the brake pedal when the HOLD function is not active.

- **Vehicles with automatic transmission:** you shift out of transmission position **P**.
- **Vehicles with automatic transmission:** you shift into transmission position **D** or **R**.
- you depress the accelerator pedal.
- you change the vehicle level.
- an automatic engine start is necessary.

If the engine was switched off by the ECO start/stop function and you leave the vehicle, a warning tone sounds. The **Vehicle is operational** **Switch off the ignition before exiting** display message also appears in the multifunction display. If you do not switch off the ignition, the ignition is automatically switched off after one minute.

Vehicles with a 48 V on-board electrical system (EQ Boost technology):

The engine is switched off automatically in the following situations if all vehicle conditions for an automatic engine stop are met:

- you brake the vehicle to a standstill in transmission position **D** or **N**.

- you engage transmission position **P**.
- you depress the brake pedal when driving at speeds below 20 km/h.

The needle of the rev counter points to zero in the multifunction display.

The engine is restarted automatically if:

- you release the brake pedal in transmission position **D** when the HOLD function is not active and the vehicle does not start to move.
- you engage transmission position **D** or **R**.
- you release the brake pedal and the vehicle starts to move on a gentle downhill gradient at a speed below 5 km/h.
- you depress the accelerator pedal.
- you change the vehicle level.
- an automatic engine start is necessary.

If the engine was switched off by the ECO start/stop function and you leave the vehicle, a warning tone sounds. The **Vehicle is operational** **Switch off the ignition before exiting** display message also appears in the multifunction display.

play. If you do not switch off the ignition, the ignition is automatically switched off after one minute.

Switching the ECO start/stop function off/on

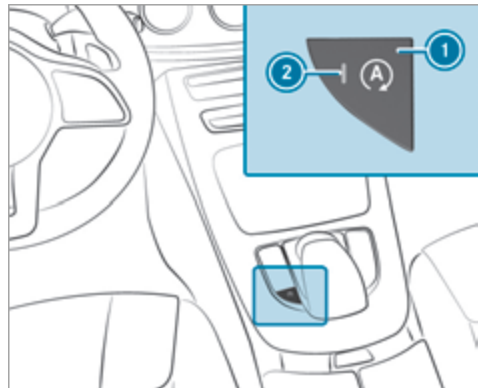

- ▶ Press button **1**.
- If indicator lamp **2** lights up, the ECO start/stop function is switched on.

- i** Depending on the model, the button may also be located at a different position in the centre console.

Function of the ECO display

The ECO display summarises the driving style from the start of the journey to its completion and assists you in achieving the most economical driving style.

You can influence consumption if you:

- drive with particular care
- drive the vehicle in drive program **E**
- observe the gearshift recommendations

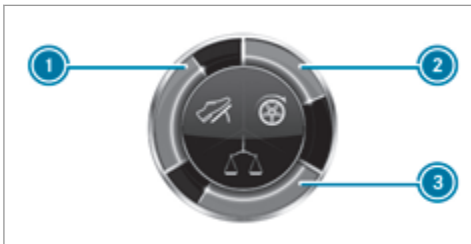

The inner segment lights up green and the outer segment fills up:

- **1** Moderate acceleration
- **2** Gentle deceleration and rolling
- **3** Consistent speed

The inner segment is grey and the outer segment empties:

- **1** Sporty acceleration
- **2** Heavy braking
- **3** Fluctuations in speed

You have driven economically when:

- the three outer segments are completely filled simultaneously.
- the ECO display border lights up.

The additional range achieved as a result of your driving style in comparison to a driver with a very sporty driving style is shown under **Bonus from start**. The range displayed does not indicate a fixed reduction in consumption.

Function of ECO Assist

Plug-in hybrid: observe the notes in the Supplement. Otherwise, you may fail to recognise dangers.

Vehicles with a 48 V on-board electrical system (EQ Boost technology):

ECO Assist analyses data for the vehicle's expected route. This allows the system to optimally adjust the driving style for the route ahead, save fuel and recuperate. If the system detects an event ahead, e.g. a speed limitation or a roundabout, it appears on the multifunction display **1**. The following symbols can be displayed:



Not all events can be displayed depending on the engine type.



A different number of segments ② appear in front of the vehicle depending on the distance to the event ahead:

- few segments: the event ahead is near.
- many segments: the event ahead is further away.

When the vehicle nears the event, ECO Assist calculates the optimal speed for maximum fuel economy and recuperative energy based on the distance, speed and downhill gradient. The **Foot off the accelerator** message appears on the multifunction display. The segments immediately in front of the vehicle turn green. The remaining segments initially stay white. If the driver takes their foot from the accelerator pedal in good time, the remaining segments in the display turn green until the event shown has been reached. The drivetrain is set for maximum fuel economy. The vehicle coasts, with the combustion engine switched off if necessary, and recuperates on its own using the electric motor. Recuperation charges the battery. Recuperation is adapted to the selected drive program.

The event is shown for a short time after it has been passed. If there is no response to the **Foot off the accelerator** prompt, the segments remain white.

If the event involves a vehicle ahead, all segments immediately turn green once there is a response to the **Foot off the accelerator** prompt.

For Active ECO Assist in drive program **E**, symbol ③ appears on the multifunction display and in the Head-up display beside transmission position **D**. Symbol ③ also appears when the assistance graphic is not selected.

If the system does not intervene during the event ahead, nothing is displayed. The system is passive.

The ECO Assist is only active in drive programs **E** and **C**.

Displaying ECO Assist

On-board computer:

- ➡ Assistance
- ▶ Select ECO Assist.

DYNAMIC SELECT switch

Function of the DYNAMIC SELECT switch

Mercedes-AMG vehicles: observe the notes in the Supplement. Otherwise, you may fail to recognise dangers.

Use the DYNAMIC SELECT switch to change between the following drive programs:

- **I (Individual):** individual settings
- **S+ (Sport Plus):** particularly sporty driving style
- **S (Sport):** sporty driving style
- **C (Comfort):** comfortable and economical driving style
- **E (Eco):** particularly economical driving style

Depending on the drive program selected, the following vehicle characteristics will change:

- drive
 - engine and transmission management
 - Active Distance Assist DISTRONIC
- ESP®

- **Vehicles with AIR BODY CONTROL or DYNAMIC BODY CONTROL:** suspension
- steering

Selecting the drive program

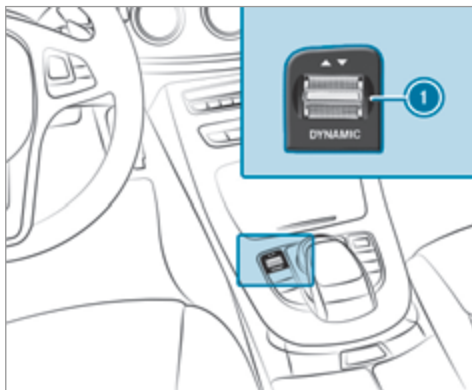

- ▶ Press DYNAMIC SELECT switch ① forwards or backwards. The drive program selected appears in the multifunction display.

Configuring drive program I

Multimedia system:

➔ Vehicle ➔ DYNAMIC SELECT ➔ Individual

- ▶ Select the individual setting.

Manual transmission

Operating the gearshift lever

! **NOTE** Damage to the engine and transmission by shifting to a gear that is too low

- ▶ When changing between gears ⑤ and ⑥ push the gearshift lever to the right.
- ▶ Do not shift down at high speeds.

! **NOTE** Damage to the transmission by shifting to reverse gear **R** while the vehicle is in motion

▶ Only shift into reverse gear **R** when the vehicle is stationary.



R Reverse gear

1 - **6** Forward gears

N Neutral

▶ Depress the clutch pedal and shift the gearshift lever into the required position.

Gearshift recommendation

The gearshift recommendation assists you in adopting an economical driving style.

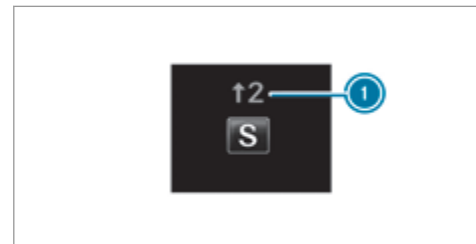

▶ If gearshift recommendation message **1** is shown on the multifunction display, shift to the recommended gear.

Automatic transmission

DIRECT SELECT lever

Function of the DIRECT SELECT lever

⚠ WARNING Risk of accident and injury due to children left unattended in the vehicle

If children are left unattended in the vehicle, they could:

- Open doors, thereby endangering other persons or road users.
- Get out of the vehicle and be hit by oncoming traffic.
- Operate vehicle equipment.

Moreover, children could also set the vehicle in motion by, for example:

- Releasing the parking brake.
- Shifting the transmission out of park position **[P]**.
- Starting the engine.

- ▶ Never leave children and animals unattended in the vehicle.
- ▶ When leaving the vehicle, always take the key with you and lock the vehicle. This also applies to mobile phones if the "Digital Car Key in the smartphone" function is activated via the Mercedes me connect web app.
- ▶ Keep the keys out of the reach of children. This also applies to mobile phones if the "Digital Car Key in the smartphone" function is activated via the Mercedes me connect web app.

⚠ WARNING Risk of accident due to incorrect gearshifting

If the engine speed is higher than the idle speed and you engage the transmission position **[D]** or **[R]**, the vehicle may accelerate sharply.

- ▶ If you engage the transmission position **[D]** or **[R]** always depress the brake

pedal firmly and do not accelerate at the same time.

Use the DIRECT SELECT lever to shift the transmission position. The current transmission position is displayed in the multifunction display.

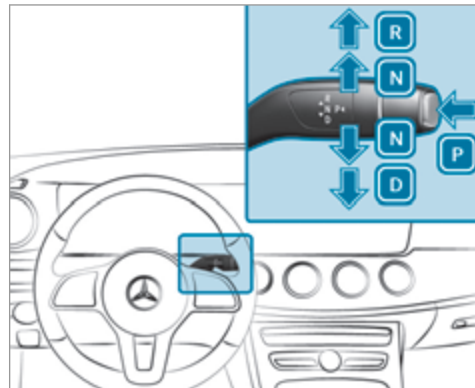

[P] Park position

[R] Reverse gear

N Neutral

D Drive position

Engaging reverse gear R

▶ Depress the brake pedal and push the DIRECT SELECT lever up past the first point of resistance.

The transmission position display shows **R** in the multifunction display.

Shifting to neutral N

▶ Depress the brake pedal and push the DIRECT SELECT lever up or down to the first point of resistance.

The transmission position display shows **N** in the multifunction display.

Subsequently releasing the brake pedal will allow you to move the vehicle freely, e.g. to push it or tow it away.

If you want the automatic transmission to remain in neutral N even if the ignition is switched off:

▶ Start the vehicle.

▶ Depress the brake pedal and shift to neutral **N**.

▶ Release the brake pedal.

▶ Switch off the ignition.

i If you then exit the vehicle leaving the key in the vehicle, the automatic transmission remains in neutral **N**.

Engaging park position P

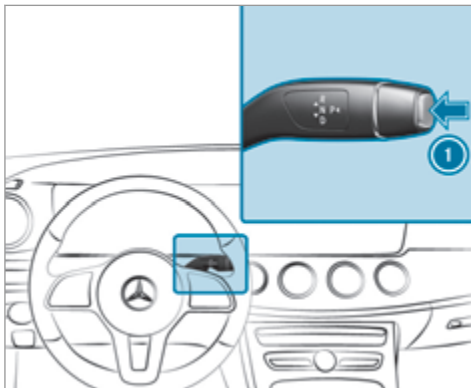

▶ Press button **1**.

The transmission position display shows **P** in the multifunction display.

Park position **P** is engaged automatically if one of the following conditions is met:

- you switch the engine off with the transmission in position **D** or **R**.
- you open the driver's door when the vehicle is stationary or when driving at a very low speed and the transmission is in position **D** or **R**.

Engaging drive position D

▶ Depress the brake pedal and push the DIRECT SELECT lever down past the first point of resistance.

The transmission position display shows **D** in the multifunction display.

When the automatic transmission is in transmission position **D**, it shifts the gears automatically. This depends on the following factors:

- the selected drive program
- the position of the accelerator pedal
- the road speed

Manual gearshifting

⚠ WARNING Risk of skidding and of an accident due to shifting down on slippery road surfaces

If you shift down on slippery road surfaces to increase the engine braking effect, the drive wheels may lose traction.

▶ Do not shift down on slippery road surfaces to increase the engine braking effect.



- ▶ **To activate:** pull steering wheel gearshift paddle ① or ②. Manual gearshifting is activated for a short time. The current gear is displayed in the multifunction display.
- ▶ **To shift up:** pull steering wheel gearshift paddle ②.
- ▶ **To shift down:** pull steering wheel gearshift paddle ①.
- ▶ **To deactivate:** pull steering wheel gearshift paddle ② and hold it in place. The transmission position **D** appears in the multifunction display.

ⓘ If you select the **Manual** drive setting in drive program **I**, manual gearshifting is permanently activated.

Mercedes-AMG vehicles: observe the notes in the Supplement. Otherwise, you may fail to recognise dangers.

Gearshift recommendation

Mercedes-AMG vehicles: observe the notes in the Supplement. Otherwise, you may fail to recognise dangers.

The gearshift recommendations assist you in adopting an economical driving style.

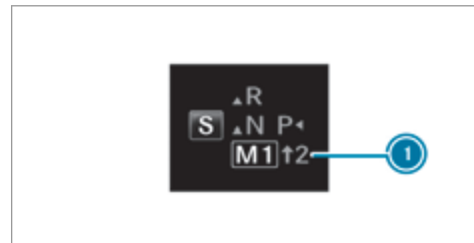

▶ If gearshift recommendation message ① is shown in the multifunction display, shift to the recommended gear.

Using kickdown

Mercedes-AMG vehicles: observe the notes in the Supplement. Otherwise, you may fail to recognise dangers.

- ▶ **Maximum acceleration:** depress the accelerator pedal beyond the pressure point.

During kickdown, you cannot shift gears using the steering wheel gearshift paddles. The automatic transmission shifts up to the next gear when the maximum engine speed is reached to protect the engine from overrevving.

- ▶ Ease off the accelerator pedal once the desired speed is reached.

Glide mode function

Mercedes-AMG vehicles: observe the notes in the Supplement. Otherwise, you may fail to recognise dangers.

With an anticipatory driving style, glide mode helps you to reduce fuel consumption.

Glide mode is characterised by the following:

- the combustion engine is disconnected from the drive train and the vehicle continues to roll in neutral.
- the transmission position **D** is displayed in green in the multifunction display.
- **Vehicles with a 48 V electrical system (EQ-Boost technology):** the combustion engine is switched off depending on the driving situation. All of the vehicle functions remain active.

Glide mode is activated if the following conditions are met:

- drive program **E** is selected.
- the speed is within a suitable range.
- the course of the road is suitable, e.g. no steep uphill or downhill gradients or tight bends.
- there is no trailer coupled to the ball coupling of the trailer tow hitch, and no bicycle rack fitted.
- you are no longer depressing the accelerator or brake pedal.

- ⓘ Glide mode can also be activated if you have selected the "Eco" setting for the drive (engine management) when in drive program **I**.

Glide mode is deactivated again if one of the conditions is no longer met.

Vehicles with Driving Assistance Package, Active Distance Assist DISTRONIC or Active Brake Assist: Glide mode is also deactivated depending on the traffic situation and the vehicle then switches to overrun mode. This further reduces fuel consumption.

Glide mode can also be prevented by the following parameters:

- uphill gradient
- downhill gradient
- temperature
- height
- speed
- obstruction detection
- operating conditions of the engine

Refuelling

Refuelling the vehicle

⚠ WARNING - Risk of fire or explosion caused by fuel

Fuels are highly inflammable.

- ▶ You must avoid fire, naked flames, creating sparks and smoking.
- ▶ Before refuelling, switch off the engine and auxiliary heating if your vehicle is equipped with auxiliary heating.

⚠ WARNING Risk of injury from fuel

Fuels are poisonous and harmful to your health

- ▶ Do not swallow fuel or let it come into contact with skin, eyes or clothing.
- ▶ Do not inhale fuel vapour.
- ▶ Keep children away from fuel.

If you or other people come into contact with fuel, observe the following:

- ▶ Immediately rinse fuel off your skin with soap and water.
- ▶ If fuel comes into contact with your eyes, immediately rinse them thoroughly with clean water. Seek medical attention immediately.
- ▶ If you swallow fuel, seek medical attention immediately. Do not induce vomiting.
- ▶ Change immediately out of clothing that has come into contact with fuel.

⚠ WARNING Risk of fire and explosion due to electrostatic charge

Electrostatic charge can cause sparks and thereby ignite fuel vapours.

- ▶ Touch the metal vehicle body before opening the fuel filler cap or touching the pump nozzle.

This discharges any electrostatic charge that may have built up.

⚠ WARNING Risk of fire from fuel mixture

Vehicles with a diesel engine:

If you mix diesel fuel with petrol, the flash point of the fuel mixture is lower than that of pure diesel fuel.

While the engine is running, component parts in the exhaust system may overheat without warning.

- ▶ Never refuel using petrol.
- ▶ Never mix petrol with diesel fuel.

! NOTE Damage caused by the wrong fuel

Vehicles with a petrol engine:

even small amounts of the wrong fuel could result in damage to the fuel system, the engine and the emission control system.

- ▶ Only refuel using unleaded fuel that conforms to EN 228, or an equivalent specification.
- ▶ The RON requirement is located in the fuel filler flap.

Fuel of this specification may contain up to 10 % ethanol. Your vehicle is suitable for use with E10 fuel.

Do not refuel using:

- diesel
- E85, E100
- petrol containing methanol (M15, M30, M85, M100)
- petrol with additives containing metal

If you accidentally refuel with the wrong fuel:

- ▶ do not switch the ignition on.
- ▶ consult a qualified specialist workshop.

! **NOTE** Damage caused by the wrong fuel

Vehicles with a diesel engine:

Even small amounts of the wrong fuel could result in damage to the fuel system, the engine and the emission control system.

▶ Only refuel using diesel fuel that conforms to EN 590, or an equivalent specification.

▶ **Vehicles with diesel particulate filters:** In countries outside the EU, only use low-sulphur Euro diesel with a sulphur content of under 50 ppm.

Do not use the following:

- Petrol
- Marine diesel
- Heating oil
- Bio-diesel
- Vegetable oil
- Paraffin
- Kerosene

If you accidentally refuel with the wrong fuel:

- ▶ Do not switch the ignition on.
- ▶ Consult a qualified specialist workshop.

! **NOTE** Do not use diesel to refuel vehicles with a petrol engine.

If you accidentally refuel with the wrong fuel:

- Do not switch on the ignition. Otherwise fuel can enter the engine.

Even small amounts of the wrong fuel could result in damage to the fuel system and the engine. The repair costs are high.

- ▶ Contact a qualified specialist workshop.
- ▶ Have the fuel tank and fuel lines drained completely.

! **NOTE** Do not use petrol to refuel vehicles with a diesel engine.

If you accidentally refuel with the wrong fuel:

- Do not switch on the ignition. Otherwise, fuel can enter the fuel system.

Even small amounts of the wrong fuel could result in damage to the fuel system and the engine. The repair costs are high.

- ▶ Contact a qualified specialist workshop.
- ▶ Have the fuel tank and fuel lines drained completely.

! **NOTE** Damage to the fuel system caused by overfilled fuel tanks.

- ▶ Only fill the fuel tank until the pump nozzle switches off.

! **NOTE** Fuel may spray out when you remove the fuel pump nozzle.

- ▶ Only fill the fuel tank until the pump nozzle switches off.

Requirements:

- unlock the vehicle.
- i** Do not get into the vehicle again during the refuelling process. Otherwise, electrostatic charge could build up again.

Please also observe the notes on service products and fuels (→ page 368).

Refuelling

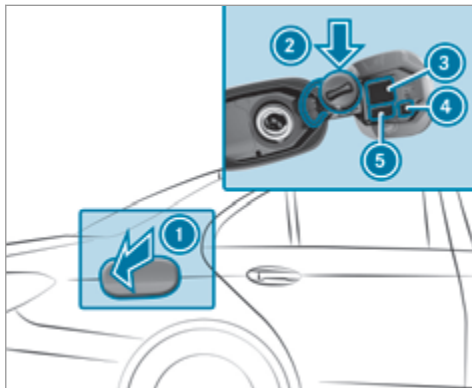

- 1** Fuel filler flap
- 2** Bracket for the fuel filler cap
- 3** Tyre pressure table
- 4** QR code for rescue card
- 5** Fuel type

- ▶ Press fuel filler flap **1**.

- ▶ Turn the fuel filler cap anti-clockwise and remove it.
- ▶ Insert the fuel filler cap into bracket **2**.
- ▶ Completely insert the fuel pump nozzle into the tank filler neck, hook in place and refuel.
- ▶ Only fill the fuel tank until the fuel pump nozzle switches off.
- i** **Vehicles with a diesel engine:** the filler neck is designed for refuelling at diesel filling pumps.
- i** **Vehicles with a diesel engine:** when the fuel tank is completely empty, refuel with at least 5 litres of diesel.
- i** **Vehicles with a diesel engine:** use a filler neck with a large diameter for vehicles with a diesel engine when topping up fuel from a fuel can. Otherwise the filler neck cannot slide into the tank.

AdBlue® (diesel engine vehicles only)

Notes on AdBlue®

! **NOTE** When you open the AdBlue® tank, small amounts of ammonia vapour may escape.

- ▶ Only fill the AdBlue® tank in well-ventilated areas.
- ▶ Do not let AdBlue® come into contact with skin, eyes or clothes.
- ▶ Keep AdBlue® away from children.

! **NOTE** Do not ingest AdBlue®.

If AdBlue® is swallowed:

- ▶ Immediately rinse out your mouth thoroughly.
- ▶ Drink plenty of water.
- ▶ Seek medical attention immediately.

Please also observe the notes on service products and fuels (→ page 368).

AdBlue® is a fluid urea solution for exhaust gas aftertreatment of diesel engines. In order for the exhaust gas aftertreatment to function properly, only use AdBlue® in accordance with ISO 22241.

AdBlue® is characterised by the following:

- non-toxic
- colourless and odourless
- non-flammable

AdBlue® availability:

- AdBlue® may be topped up by fast service at a qualified specialist workshop, e.g. a Mercedes-Benz Service Centre.
- AdBlue® is available at many filling stations from AdBlue® filling pumps.
- Alternatively, AdBlue® is available at qualified specialist workshops, e.g. Mercedes-Benz Service Centres, and at many filling stations in AdBlue® refill canisters or AdBlue® refill bottles.

i Ensure the connection between the refill container and vehicle filler neck does not drip.

Topping up AdBlue®

! **NOTE** Engine damage due to AdBlue® in the fuel

- ▶ AdBlue® must not be used to fill the fuel tank.
- ▶ Only use AdBlue® to fill the AdBlue® tank.
- ▶ Do not overfill the AdBlue® tank.

! **NOTE** Contamination of the vehicle interior due to AdBlue® leakage

- ▶ After topping up, carefully close the AdBlue® refill container.
- ▶ Avoid carrying AdBlue® refill containers permanently in the vehicle.

Requirements:

- unlock the vehicle.

The following announcements appear in order in the multifunction display when the AdBlue® tank requires refilling:

- **Refill AdBlue See Owner's Manual.** The AdBlue® reservoir is down to the reserve level.
- **Refill AdBlue No start in XXX km.** You can only drive the vehicle over the distance shown. Top up AdBlue® as soon as possible.
- **Refill AdBlue Start not possible.** The vehicle can no longer be started.

Opening the AdBlue® filler cap

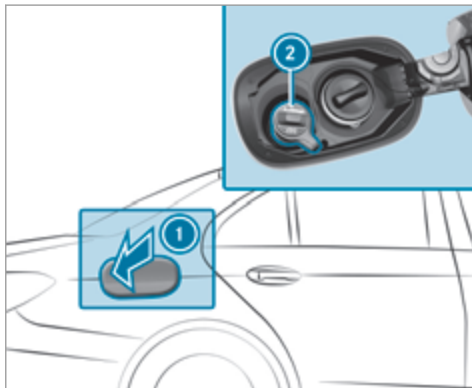

- ▶ Press fuel filler flap ①.
- ▶ Turn AdBlue® filler cap ② anti-clockwise and remove it.

Preparing the AdBlue® refill canister

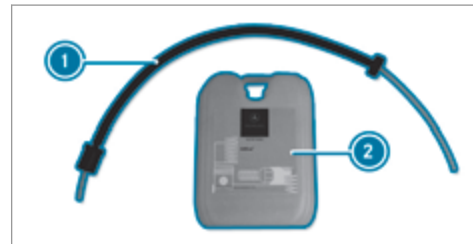

- ▶ Screw on the fastener of AdBlue® refill canister ②.
- ▶ Screw disposable hose ① onto the opening of AdBlue® refill canister ② until finger-tight.

Topping up AdBlue®

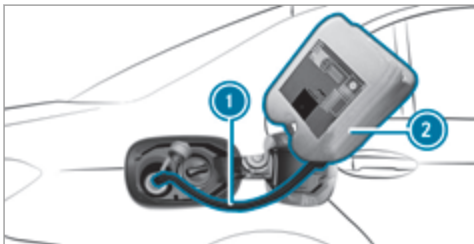

- ▶ Screw disposable hose ① onto the filler neck of the vehicle until finger-tight.
- ▶ Lift up and tip AdBlue® refill canister ②. The filling process stops when the AdBlue® tank is completely full. AdBlue® refill canister ② can be removed when it has been only partially emptied.
- ▶ Unscrew and close disposable hose ① and AdBlue® refill canister ② in reverse order.
- ▶ Switch on the ignition for at least 60 seconds.
- ▶ Start the vehicle.

- ① Avoid storing AdBlue® refill containers permanently in the vehicle.

Parking

Switching off the vehicle

- ⚠ **WARNING** Risk of fire caused by hot exhaust system parts

Flammable material such as leaves, grass or twigs may ignite if they come into contact with hot parts of the exhaust system or exhaust gas flow.

- ▶ Park the vehicle so that no flammable material can come into contact with hot vehicle components.
- ▶ In particular, do not park on dry grass-land or harvested grain fields.

- ⚠ **WARNING** Risk of accident and injury due to children left unattended in the vehicle

If you leave children unattended in the vehicle, they may be able to set the vehicle in motion, for example by:

- Releasing the parking brake.
- Shifting the automatic transmission out of park position **P** or shifting the manual transmission into neutral.
- Starting the engine.

In addition, they may operate vehicle equipment.

- ▶ Never leave children and animals unattended in the vehicle.
- ▶ When leaving the vehicle, always take the key with you and lock the vehicle. This also applies to mobile phones if the "Digital Car Key in the smartphone" function is activated via the Mercedes connect me web app.

! **NOTE** Damage to the vehicle or the drivetrain caused by the vehicle rolling away

- ▶ Always properly secure the vehicle against rolling away.

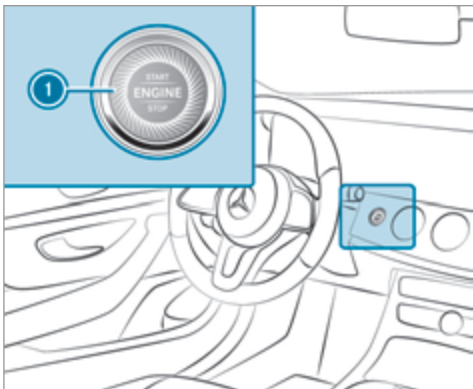

- ▶ On uphill or downhill inclines, turn the front wheels towards the kerb.

- ▶ **Vehicles with manual transmission:** engage first **1** or reverse gear **R**.

- ▶ **Vehicles with automatic transmission:** engage transmission position **P**.

- ▶ Apply the electric parking brake.

- ▶ Press button **1** once.

- i** When you switch off the vehicle, you can still operate the side windows and the panorama sliding sunroof for five minutes.

Garage door opener

Programming buttons for the garage door opener

! **WARNING** Risk of exhaust gas poisoning

Combustion engines emit poisonous exhaust gases such as carbon monoxide. Inhaling these exhaust gases causes poisoning.

- ▶ Never leave the engine running in an enclosed space without sufficient ventilation.

! **WARNING** Risk of injury and entrapment when opening the garage door using the garage door opener

When you operate or program the garage door with the integrated garage door opener, persons in the range of movement of the garage door can become trapped or struck by the garage door.

- ▶ When using the integrated garage door opener, always make sure that nobody is within the sweep of the garage door.

Requirements:

- The vehicle is parked outside of the garage.
- The engine is switched off.

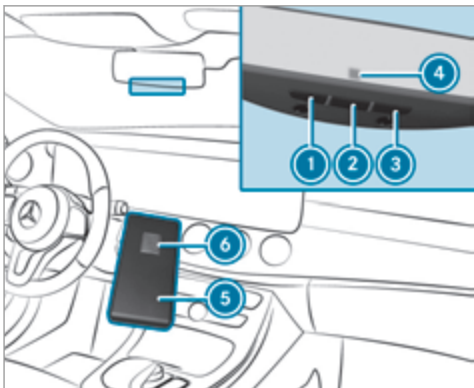

- ▶ Press and hold button ①, ② or ③ that you wish to program. Indicator lamp ④ flashes yellow.

ⓘ It can take up to 20 seconds before the indicator lamp flashes yellow.

- ▶ Release the previously pressed button. Indicator lamp ④ continues to flash yellow.

- ▶ Point remote control ⑤ at a distance of 1 cm to 8 cm towards buttons ①, ② or ③.
 - ▶ Press and hold button ⑥ of remote control ⑤ until:
 - Indicator lamp ④ lights up green continuously. Programming is complete.
 - Indicator lamp ④ flashes green. Programming was successful. Additionally, synchronisation of the rolling code with the garage door system must also be carried out.
 - ▶ If indicator lamp ④ does not light up or flash green: repeat the procedure.
 - ▶ Release all of the buttons.
- ⓘ The remote control for the garage door drive is not included in the scope of delivery of the garage door opener.

Synchronising the rolling code

Requirements:

- The garage door system uses a rolling code.
- The vehicle must be within range of the garage door or exterior gate drive.

- The vehicle as well as persons and objects, are located outside the sweep of the garage door.

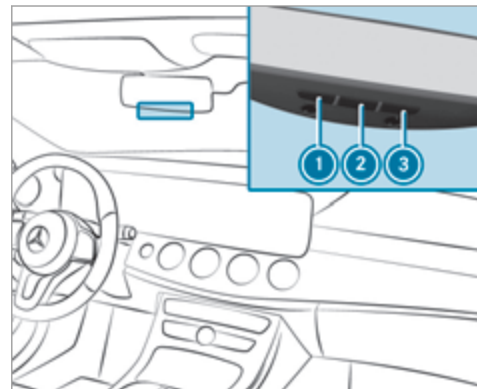

- ▶ Press the programming button on the door drive unit. Initiate the next step within approximately 30 seconds.

▶ Press previously programmed button ①, ② or ③ repeatedly, until the door closes. When the door closes, programming is completed.

ⓘ Please also read the operating instructions for the garage door drive.

Troubleshooting when programming the remote control

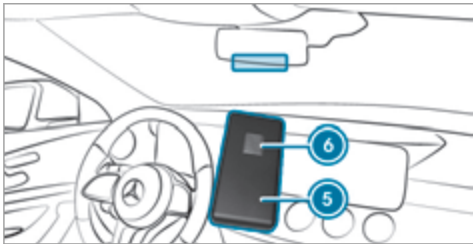

▶ Check if the transmitter frequency of remote control ⑤ is supported.

▶ Replace the batteries in remote control ⑤.

▶ Hold remote control ⑤ at various angles at a distance between 1 cm to 8 cm in front of

the inside rearview mirror. You should test every position for at least 25 seconds before trying another position.

▶ Hold remote control ⑤ at the same angles at various distances in front of the inside rear view mirror. You should test every position for at least 25 seconds before trying another position.

▶ Note that some remote controls transmit only for a limited period, press button ⑥ on remote control ⑤ again before transmission ends.

▶ Align the aerial line of the garage door opener unit with the remote control.

ⓘ Support and additional information on programming:

- On the HomeLink® Hotline on (0) 08000 466 354 65 or +49 (0) 6838 907-277.
- On the Internet at <http://www.homelink.com>.

Opening/closing the garage door

Requirements:

- The corresponding button is programmed to operate the garage door.

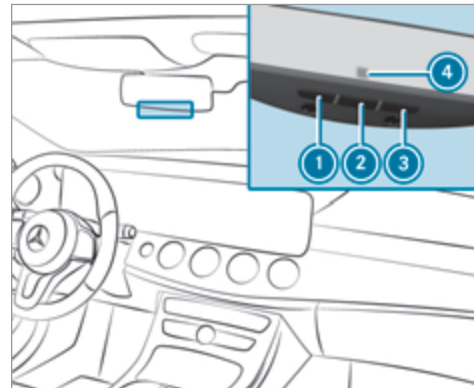

▶ Press and hold buttons ①, ② or ③ until the garage door opens or closes.

▶ If indicator lamp ④ flashes yellow after approximately 20 seconds: press and hold

the previously pressed button again until the garage door opens or closes.

Clearing the garage door opener memory

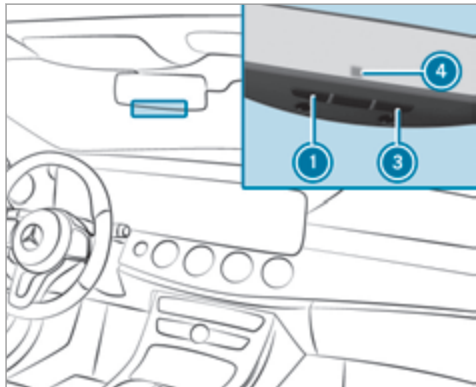

- ▶ Press and hold buttons ① and ③. Indicator lamp ④ lights up yellow.
- ▶ If indicator lamp ④ flashes green: release buttons ① and ③.

Radio equipment approval numbers for the garage door opener

Radio equipment approval numbers

Country	Radio equipment approval number
Egypt	TAC.2511151293.WIR
Andorra	CE
Australia	R-NZ
Barbados	MED1578
Chile	2488/DFRS20576/F-74
European Union	CE
Gibraltar	CE
Iceland	CE
Jordan	TRC/LPD/2015/299
Canada	IC: 4112A-MUAHL5
Kuwait	CE

Country	Radio equipment approval number
Liechtenstein	CE
Mexico	RCPGEMU15-0448
Monaco	CE
New Zealand	R-NZ
Norway	CE
Russian Federation	not required
Saudi Arabia	TA 10525
Switzerland	CE

Country	Radio equipment approval number
South Africa	 TA-2015/1386
Turkey	not required
United Arab Emirates	ER41849/15 Dealer No: DA35176/14
United States	FCC ID: NZLMUAHL5

Brazil



Este equipamento opera em caráter secundário, isto é, não tem direito à proteção contra interferência prejudicial, mesmo de estações do mesmo tipo, e não pode causar interferência a sistemas operando em caráter primário.

Para maiores informações acessar www.anatel.gov.br

Further information on the declaration of conformity for wireless vehicle components (→ page 24).

Electric parking brake

Electric parking brake function (applying automatically)

⚠ WARNING Risk of accident and injury due to children left unattended in the vehicle

If you leave children unattended in the vehicle, they may be able to set the vehicle in motion, for example by:

- Releasing the parking brake.
- Shifting the automatic transmission out of park position **P** or shifting the manual transmission into neutral.
- Starting the engine.

In addition, they may operate vehicle equipment.

- ▶ Never leave children and animals unattended in the vehicle.
- ▶ When leaving the vehicle, always take the key with you and lock the vehicle. This also applies to mobile phones if the "Digital Car Key in the smartphone"

function is activated via the Mercedes connect me web app.

Vehicles with manual transmission:

When the vehicle comes to a standstill, the electric parking brake is applied if one of the following conditions is fulfilled:

- The engine is switched off.
- The seat belt tongue is not inserted in the seat belt buckle of the driver's seat and the driver's door is opened.

The electric parking brake is also applied while the vehicle kept stationary by the HOLD function if one of the following conditions is fulfilled:

- The engine is switched off.
- The seat belt tongue is not inserted in the seat belt buckle of the driver's seat and the driver's door is opened.
- There is a system malfunction.
- The power supply is insufficient.
- The vehicle is stationary for a lengthy period.

When the electric parking brake is applied, the  indicator lamp lights up in the instrument cluster.

The electric parking brake is not automatically applied if the engine is switched off by the ECO start/stop function.

 To prevent application: pull the handle of the electric parking brake.

Vehicles with automatic transmission:

The electric parking brake is applied if the transmission is in position  and one of the following conditions is fulfilled:

- The engine is switched off.
- The seat belt tongue is not inserted in the seat belt buckle of the driver's seat and the driver's door is opened.

 To prevent application: pull the handle of the electric parking brake.

In the following situations, the electric parking brake is also engaged:

- The Active Distance Assistant DISTRONIC is bringing the vehicle to a standstill.

- The HOLD function is keeping the vehicle stationary.
- Active Parking Assist is keeping the vehicle stationary.

This is only the case if one of the following conditions is also fulfilled:

- The engine is switched off.
- The seat belt tongue is not inserted in the seat belt buckle of the driver's seat and the driver's door is opened.
- There is a system malfunction.
- The power supply is insufficient.
- The vehicle is stationary for a lengthy period.

When the electric parking brake is applied, the  indicator lamp lights up in the instrument cluster.

The electric parking brake is not automatically applied if the engine is switched off by the ECO start/stop function.

Electric parking brake function (releasing automatically)

Vehicles with manual transmission:

The electric parking brake is released when the following conditions are fulfilled:

- The driver's door is closed.
- The engine is running.
- A gear has been selected, you release the clutch pedal and depress the accelerator pedal.
- When reverse gear **R** is selected, the boot lid must be closed.

If the electric parking brake is released, the **(P)** indicator lamp in the instrument cluster goes out.

Vehicles with automatic transmission:

The electric parking brake is released when the following conditions are fulfilled:

- The engine is running.
- The seat belt tongue is inserted into the seat belt buckle of the driver's seat.
- The transmission is in position **D** or **R** and you depress the accelerator pedal or you shift from transmission position **P** to **D** or **R**.

- If the transmission is in position **R**, the boot lid must be closed.

If the seat belt tongue is not inserted into the seat belt buckle of the driver's seat, the following conditions must be fulfilled:

- The driver's door is closed.
- You move the transmission out of transmission position **P** or you have previously driven faster than 3 km/h.
- If the transmission is in position **R**, the boot lid must be closed.

If the electric parking brake is released, the **(P)** indicator lamp in the instrument cluster goes out.

Applying or releasing the electric parking brake manually

Applying

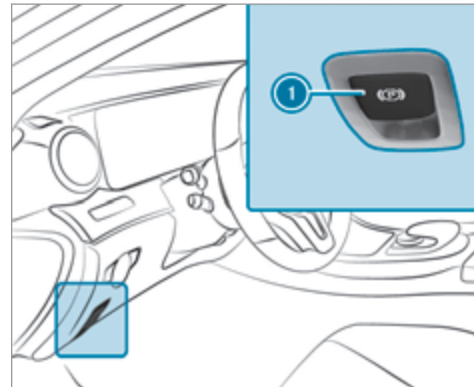

- ▶ Push handle **1**.
The **(P)** indicator lamp appears in the instrument cluster.

- ⓘ The electric parking brake is only securely applied if the indicator lamp is lit continuously.

Releasing

- ▶ Switch the ignition on.
- ▶ Pull handle ①.
The  indicator lamp in the instrument cluster goes out.

Emergency braking

- ▶ Press and hold handle ①.
When the vehicle has been braked to a standstill, the electric parking brake is applied. The  indicator lamp appears in the instrument cluster.

Information on detecting damage on a parked vehicle

If a collision is detected when the tow-away protection is activated on a locked vehicle, you will receive notification:

- on your smartphone

- in the multimedia system when you switch on the ignition

You will receive information about the following:

- the area of the vehicle that may have been damaged
- the force of the impact

The following situations can lead to inadvertent activation:

- the parked vehicle is moved, e.g. in a double-decker garage
- ⓘ Deactivate tow-away protection in order to prevent inadvertent activation. If you deactivate tow-away protection, damage detection will also be deactivated.

System limitations

Detection may be restricted in the following situations:

- the vehicle is damaged without impact, e.g. if an outside mirror is torn off or the paint is damaged by a key
- an impact occurs at low speed

- the electric parking brake is not applied

Information on Mercedes me connect and other services: <http://www.mercedes.me>.

Notes on parking up the vehicle

If you leave the vehicle parked up for longer than four weeks, the disconnected battery may be damaged by deep discharge.

If you leave the vehicle parked up for longer than six weeks, it may suffer damage as a result of lack of use.

- ⓘ Further information can be obtained at a qualified specialist workshop.

Standby mode (extension of the starter battery's period out of use)

Standby mode function Vehicles without a 48 V electrical system (EQ Boost technology):

If standby mode is activated, the vehicle can be parked for an extended period of time without losing power.

Standby mode is characterised by the following:

- the starter battery is preserved.
- the maximum period out of use is displayed in the multimedia system display.
- functions such as interior protection or tow-away protection are not available.
- the connection to online services is interrupted.

If the following conditions are fulfilled, standby mode can be activated or deactivated using the multimedia system:

- the engine is switched off.
- the ignition is switched on.

Exceeding the vehicle's displayed period out of use may cause inconvenience, i.e. it cannot be guaranteed that the starter battery will reliably start the engine.

The starter battery must be charged first in the following situations:



- the vehicle's period out of use must be extended.



- the **Battery charge insufficient for standby mode** message appears in the multimedia system display.

 Standby mode is automatically deactivated when the ignition is switched on.

Activating or deactivating standby mode Vehicles without a 48 V electrical system (EQ Boost technology):

Multimedia system:

 **Vehicle**  **Vehicle settings**  **Standby mode**

-  Activate or deactivate the function. When you activate the function, a prompt appears.
-  Select **Yes**. Standby mode is activated.

Driving and driving safety systems

Driving systems and your responsibility

Your vehicle is equipped with driving systems which assist you in driving, parking and manoeu-

ring the vehicle. The driving systems are tools and do not relieve you of your responsibility. Pay attention to the traffic conditions at all times and intervene when necessary. Be aware of the limitations regarding the safe use of these systems.

Function of the radar sensors

Some driving and driving safety systems use radar sensors to monitor the area in front of, behind or next to the vehicle (depending on the vehicle's equipment).

Depending on the vehicle's equipment, the radar sensors are integrated behind the bumpers and/or behind the radiator grille. Keep these parts free of dirt, ice and slush (→ page 317). The sensors must not be covered, for example by bicycle racks, overhanging loads or radar-reflecting stickers. Following an impact and in the event of associated damage, which may not be visible, to the bumpers or radiator grille, have the function of the radar sensors checked at a qualified specialist workshop. The driver assistance system may no longer work properly.

Overview of driving systems and driving safety systems

In this section, you will find information about the following driving systems and driving safety systems:

- 360° Camera (→ page 223)
- ABS (**A**nti-**l**ock **B**raking **S**ystem) (→ page 191)
- Active Distance Assist DISTRONIC (→ page 205)
- Adaptive brake lights (→ page 201)
- AIR BODY CONTROL (→ page 213)
- Active Brake Assist (→ page 196)
- Active Lane Keeping Assist (→ page 241)
- ATTENTION ASSIST (→ page 237)
- BAS (**B**rake **A**ssist **S**ystem) (→ page 191)
- DYNAMIC BODY CONTROL (→ page 213)
- EBD (**E**lectronic **B**rake force **D**istribution) (→ page 196)
- ESP® (**E**lectronic **S**tability **P**rogram) (→ page 192)
- Hill Start Assist

- HOLD function (→ page 212)
- STEER CONTROL (→ page 196)
- Active Steering Assist (→ page 210)
- Limiter (→ page 202)
- Active Parking Assist (→ page 226)
- Parking Assist PARKTRONIC (→ page 216)
- Reversing camera (→ page 220)
- Cruise control (→ page 201)
- Blind Spot Assist and Active Blind Spot Assist (→ page 239)

Functions of ABS (anti-lock braking system)

ABS regulates the brake pressure in critical driving situations:

- During braking, e.g. at maximum full-stop braking or insufficient traction of the tyres, the wheels are prevented from blocking.
- Vehicle steerability while braking is ensured.

If ABS intervenes when braking, you will feel a pulsing in the brake pedal. The pulsating brake pedal can be an indication of hazardous road

conditions and can serve as a reminder to take extra care while driving.

System limitations

- ABS is active from speeds of approx. 8 km/h.
- ABS may be impaired or may not function if a malfunction has occurred and the yellow  ABS warning lamp lights up continuously in the instrument cluster after the engine is started.

Function of BAS (Brake Assist System)

⚠ WARNING Risk of an accident caused by a malfunction in BAS (Brake Assist System)

If BAS is malfunctioning, the braking distance in an emergency braking situation is increased.

▶ Depress the brake pedal with full force in emergency braking situations. ABS prevents the wheels from locking.

BAS supports your emergency braking situation with additional brake force.

If you depress the brake pedal quickly, BAS is activated:

- BAS automatically boosts the brake pressure.
- BAS can shorten the braking distance.
- ABS prevents the wheels from locking.

The brakes will function as usual once you release the brake pedal. BAS is deactivated.

Functions of ESP® (Electronic Stability Program)

⚠ WARNING Risk of skidding if ESP® is malfunctioning

If ESP® is malfunctioning, ESP® cannot carry out vehicle stabilisation. In addition, other driving safety systems are switched off.

▶ Drive on carefully.

▶ Have ESP® checked at a qualified specialist workshop.

⚠ WARNING Risk of skidding if ESP® is deactivated

If you deactivate ESP®, ESP® cannot carry out vehicle stabilisation.

▶ ESP® should only be deactivated in the following situations.

Mercedes-AMG vehicles: always observe the notes in the Supplement. Otherwise, you may fail to recognise dangers.

ESP® can monitor and improve driving stability and traction in the following situations, within physical limits:

- When pulling away on wet or slippery carriageways.
- When braking.
- **Vehicles with trailer hitch:** In trailer operation from speeds of 65 km/h, if the vehicle/

trailer combination begins to sway from side to side.

- In strong sidewinds when you are driving faster than 80 km/h.

If the vehicle deviates from the direction desired by the driver, ESP® can stabilise the vehicle by intervening in the following ways:

- One or more wheels are braked.
- The engine output is adapted according to the situation.

ESP® is deactivated if the ESP® OFF  warning lamp lights up continuously in the instrument cluster:

- Driving stability will no longer be improved.
- **Vehicles with trailer hitch:** Stabilisation of the vehicle/trailer combination is no longer active.
- Crosswind Assist is no longer active.
- The drive wheels could spin.
- ETS/4ETS traction control is still active.

i When ESP® is deactivated, you are still assisted by ESP® when braking.

ESP® is intervening if the ESP®  warning lamp flashes in the instrument cluster:

- Do not deactivate ESP®.
- Only depress the accelerator pedal as far as is necessary.
- Adapt your driving style to suit the current road and weather conditions.

Deactivate ESP® in the following situations to improve traction:

- When using snow chains.

- In deep snow.
- On sand or gravel.

i Spinning the wheels results in a cutting action which provides better grip.

If the ESP®  warning lamp lights up continuously, ESP® is not available due to a malfunction.

Observe the following information:

- Warning and indicator lamps (→ page 438)
- Display messages (→ page 381)

ETS/4ETS (Electronic Traction System)

ETS/4ETS traction control is part of ESP® and makes it possible to pull away and accelerate on a slippery carriageway.

ETS/4ETS can improve the vehicle's traction by intervening in the following ways:

- The drive wheels are braked individually if they spin.
- More drive torque is transferred to the wheel or wheels with traction.

Influence of drive programs on ESP®

The drive programs enable ESP® to adapt to different weather and road conditions as well as the driver's preferred driving style. You can select the drive programs using the DYNAMIC SELECT switch (→ page 170).

ESP® characteristics per drive program

Drive program	ESP® mode	Characteristics
<p>C (Comfort) E (Economy)</p>	<p>ESP® Comfort</p>	<p>These drive programs provide the ideal balance between traction and stability.</p> <p>Select drive program E or C in difficult road conditions, such as in snow or ice, or when the road is wet from rain.</p>
<p>S (Sport)</p>	<p>ESP® Sport</p>	<p>This drive program continues to offer stability but with a sporty setup which allows the enthusiastic driver a more active driving style.</p> <p>Only select drive program S in good road conditions, for example on dry roads and clear stretches of road.</p>
<p>S+ (Sport Plus)</p>	<p>ESP® Sport Plus</p>	<p>The vehicle's own understeering and oversteering characteristics are accentuated. This allows a more active driving style to be adopted.</p> <p>Only select drive program S+ in good road conditions, for example on dry roads and clear stretches of road.</p>

Activating/deactivating ESP® (Electronic Stability Program)

Multimedia system:

↳ Vehicle ▶ Assistance ▶ Electronic Stability Program

Mercedes-AMG vehicles: always observe the notes in the Supplement. Otherwise, you may fail to recognise dangers.

▶ Activate or deactivate the function.

ESP® is deactivated if the  ESP® OFF warning lamp lights up continuously in the instrument cluster.

Observe the information on warning lamps and display messages which may be shown in the instrument cluster.

Functions of ESP® Crosswind Assist

ESP® Crosswind Assist detects sudden gusts of side wind and helps the driver to keep the vehicle in the lane:

- ESP® Crosswind Assist is active at vehicle speeds between 80 km/h and 200 km/h when driving straight ahead or cornering slightly.
- The vehicle is stabilised by means of individual brake application on one side.

Functions of ESP® trailer stabilisation

⚠ WARNING Risk of accident in poor road and weather conditions

In poor road and weather conditions, the trailer stabilisation cannot prevent lurching of the vehicle/trailer combination. Trailers with a high centre of gravity may tip over before ESP® detects this.

▶ Always adapt your driving style to suit the current road and weather conditions.

When driving with a trailer, ESP® can stabilise your vehicle if the trailer begins to swerve from side to side:

- ESP® trailer stabilisation is active above speeds of 65 km/h.
- Slight swerving is reduced by means of a targeted, individual brake application on one side.
- In the event of severe swerving, the engine output is also reduced and all wheels are braked.

ESP® trailer stabilisation may be impaired or may not function if:

- The trailer is not connected correctly or is not detected properly by the vehicle.

Function of EBD (Electronic Brake force Distribution)

EBD is characterised by the following:

- Monitoring and regulating the brake pressure on the rear wheels.
- Improved driving stability when braking, especially on bends.

STEER CONTROL function

STEER CONTROL helps you by transmitting a noticeable steering force to the steering wheel in the direction required for vehicle stabilisation.

This steering recommendation is given particularly in the following situations:

- Both right wheels or both left wheels are on a wet or slippery road surface when you brake.
- The vehicle starts to skid.

System limitations

STEER CONTROL may be impaired or may not function in the following situations:

- ESP® is deactivated.
- ESP® is malfunctioning.
- The steering is malfunctioning.

If ESP® is malfunctioning, you will be assisted further by the electric power steering.

Function of Active Brake Assist

Active Brake Assist consists of:

- Distance warning function
- Autonomous braking function
- Situation-dependent braking assistance
- **Vehicles with Driving Assistance Package:** Evasive Steering Assist

Active Brake Assist can help you to minimise the risk of a collision with vehicles or pedestrians or to reduce the effects of such a collision.

If Active Brake Assist has detected a risk of collision, you will be warned visually and acoustically.

If you do not react to the visual or acoustic warning, autonomous braking can be initiated in critical situations.

In especially critical situations, Active Brake Assist can initiate autonomous braking directly. In this case, the visual and acoustic warning occurs simultaneously with the braking application.

If you apply the brake yourself in a critical situation or apply the brake during autonomous braking, situation-dependent braking assistance occurs. The brake pressure increases up to maximum full-stop braking if necessary.

If the autonomous braking function or the situation-dependent braking assistance is triggered, additional preventive measures for occupant protection (PRE-SAFE®) may also be initiated, if the vehicle is equipped with these.

⚠ WARNING Risk of an accident caused by limited detection performance of Active Brake Assist

Active Brake Assist cannot always clearly identify objects and complex traffic situations.

In such cases, Active Brake Assist might:

- Give a warning or brake without reason
 - Not give a warning or not brake
- ▶ Always pay careful attention to the traffic situation; do not rely on Active Brake Assist alone. Active Brake Assist is only an aid. The driver is responsible for

maintaining a suitable distance to the vehicle in front, vehicle speed and for braking in good time.

- ▶ Be prepared to brake or swerve if necessary.

Also observe the system limitations of Active Brake Assist.

The individual subfunctions are available in the following speed ranges:
Distance warning function

The distance warning function issues a warning at speeds:

- From approximately 30 km/h, if over several seconds the distance maintained to the vehi-

cle travelling in front is insufficient for the driving speed. The  distance warning lamp then lights up in the instrument cluster.

- From approximately 7 km/h, if your vehicle is critically close to a vehicle or pedestrian. An intermittent warning tone sounds and the  distance warning lamp lights up in the instrument cluster.

Brake immediately or take evasive action, provided it is safe to do so and the traffic situation allows this.

The distance warning function can aid you in the following situations with an intermittent warning tone and a warning lamp:

	Vehicles travelling in front	Stationary vehicles	Crossing vehicles	Crossing pedestrians	Stationary pedestrians
Vehicles without Driving Assistance package	up to approx. 250 km/h	up to approx. 80 km/h	no reaction	up to approx. 60 km/h	no reaction
Vehicles with Driving Assistance package	up to approx. 250 km/h	up to approx. 100 km/h	up to approx. 70 km/h	up to approx. 70 km/h	up to approx. 70 km/h

Autonomous braking function

The autonomous braking function may intervene at speeds starting from approximately 7 km/h in the following situations:

	Vehicles travelling in front	Stationary vehicles	Crossing vehicles	Crossing pedestrians	Stationary pedestrians
Vehicles without Driving Assistance package	up to approx. 200 km/h	up to approx. 50 km/h	no reaction	up to approx. 60 km/h	no reaction
Vehicles with Driving Assistance package	up to approx. 250 km/h	up to approx. 100 km/h	up to approx. 70 km/h	up to approx. 70 km/h	up to approx. 70 km/h

Situation-dependent braking assistance

Situation-dependent braking assistance may intervene at speeds starting from approximately 7 km/h in the following situations:

	Vehicles travelling in front	Stationary vehicles	Crossing vehicles	Crossing pedestrians	Stationary pedestrians
Vehicles without Driving Assistance package	up to approx. 250 km/h	up to approx. 80 km/h	no reaction	up to approx. 60 km/h	no reaction
Vehicles with Driving Assistance package	up to approx. 250 km/h	up to approx. 100 km/h	up to approx. 70 km/h	up to approx. 70 km/h	up to approx. 70 km/h

Cancelling a brake application of Active Brake Assist

You can cancel a brake application of Active Brake Assist at any time by:

- Fully depressing the accelerator pedal or with kickdown.
- **Vehicles without Driving Assistance package:** releasing the brake pedal

Active Brake Assist may cancel the brake application when one of the following conditions is fulfilled:

- You manoeuvre to avoid the obstacle.
- There is no longer a risk of collision.
- An obstacle is no longer detected in front of your vehicle.

Evasive Steering Assist (only vehicles with Driving Assistance Package)

Evasive Steering Assist has the following characteristics:

- Can detect stationary or crossing pedestrians.
- Can assist the driver with additional steering assistance if it detects a swerving manoeuvre.
- Can be activated by an abrupt steering movement during a swerving manoeuvre.

- Can assist during swerving and straightening of the vehicle.
- Can react from a speed of approximately 20 km/h up to a speed of approximately 70 km/h.

You can prevent the assistance at any time by actively steering.

⚠ WARNING Risk of an accident despite Evasive Steering Assist

Evasive Steering Assist cannot always clearly identify objects and complex traffic situations.

In addition, the steering support of Evasive Steering Assist is generally not sufficient to avoid a collision.

In such cases Evasive Steering Assist can:

- give an unnecessary warning or provide assistance
- not give a warning or not provide assistance

- ▶ Always pay careful attention to the traffic situation; do not rely on Evasive Steering Assist alone.
- ▶ Be ready to brake and take evasive action, if necessary.
- ▶ Prevent the assistance by actively steering in non-critical driving situations.
- ▶ Drive at an appropriate speed if pedestrians are close to the path of your vehicle.

Also observe the system limitations of Evasive Steering Assist.

System limitations

The system may be impaired or may not function in the following situations:

- In snow, rain, fog, heavy spray, if there is glare, in direct sunlight or in greatly varying light conditions.
- If the sensors are dirty, misted up, damaged or covered.

- If the sensors malfunction due to other radar source interference, for example strong radar reflections in multi-storey car parks.
- If a loss of tyre pressure or a defective tyre has been detected and displayed.

The system may not react correctly:

- In complex traffic situations where objects cannot always be clearly identified.
- To pedestrians or vehicles if they move quickly into the sensor detection range.
- To pedestrians who are hidden by other objects.
- If the typical outline of a pedestrian cannot be distinguished from the background.
- If a pedestrian is not recognised as such, e.g. due to special clothing or other objects.
- On bends with a tight radius.

Setting Active Brake Assist

Multimedia system:

↳ Vehicle ▶ Assistance ▶ Active Brake Assist

Vehicles without Driving Assistance package: The settings can be made after starting the vehicle.

Vehicles with Driving Assistance package: The settings can be made when the ignition is switched on.

 It is recommended that you always leave Active Brake Assist switched on.



The moment of warning or intervention can be adjusted as follows:

- ▶ **Select Warning/brake applic.: early:** your selection is retained when the vehicle is next started.
- ▶ **Select Warn./brake applic.: medium:** your selection is retained when the vehicle is next started.

▶ **Select Warning/brake applic.: late:** your selection is retained when the vehicle is next started.

▶ **Select Warning/brake applic.: off: Vehicles without Driving Assistance package:** The distance warning function and the autonomous braking function are deactivated. When the vehicle is next started, the medium setting is automatically selected.

Vehicles with Driving Assistance package: The distance warning function and the autonomous braking function are deactivated. Evasive Steering Assist is unavailable. When the ignition is next started, the medium setting is selected automatically and Evasive Steering Assist is available.

 When Active Brake Assist is deactivated, the  symbol appears in the assistance graphic in the multifunction display.

Adaptive Brake Lights function

Adaptive Brake Lights warn following traffic in an emergency braking situation:

- By flashing brake lamps
- By activating the hazard warning lights

If the vehicle is braked sharply from speeds above 50 km/h, the brake lamps flash rapidly. This provides traffic travelling behind you with an even more noticeable warning.

If the vehicle is travelling at speeds of more than 70 km/h at the beginning of the brake application, the hazard warning lights switch on once the vehicle is stationary. When pulling away again, the hazard warning lights switch off automatically at approximately 10 km/h. You can also switch off the hazard warning lights using the hazard warning button.

Cruise control and limiter

Function of cruise control

Cruise control accelerates and brakes the vehicle automatically in order to maintain a previously stored speed.

If you accelerate to overtake, for example, the stored speed is not deleted. If you remove your foot from the accelerator pedal after overtaking, cruise control will resume speed regulation back to the stored speed.

You can operate cruise control with the cruise control lever.

If you fail to adapt your driving style, cruise control can neither reduce the risk of an accident nor override the laws of physics. It cannot take into account road, weather or traffic conditions. Cruise control is only an aid. You are responsible for the distance to the vehicle in front, for vehicle speed, for braking in good time and for staying in lane.

System limitations

Cruise control may be unable to maintain the stored speed on uphill gradients. The stored speed is resumed when the gradient evens out.

Change into a lower gear in good time on long and steep downhill gradients. Take particular note of this when driving a laden vehicle. By doing so, you will make use of the braking effect of the engine. This relieves the load on the brake

system and prevents the brakes from overheating and wearing too quickly.

Do not use cruise control in the following situations:

- In traffic situations which require frequent changes of speed, e.g. in heavy traffic, on winding roads.
- On slippery roads. Accelerating can cause the drive wheels to lose traction and the vehicle could then skid.
- If you are driving when visibility is poor.

Function of the limiter

The limiter restricts the speed of the vehicle. To reduce the speed swiftly to the set speed, the limiter applies the brakes automatically.

You can limit the speed as follows:

- Variable: for speed limits, e.g. in built-up areas.
- Permanent: for long-term speed restrictions, e.g. when driving with winter tyres fitted.

If you fail to adapt your driving style, the limiter can neither reduce the risk of an accident nor

override the laws of physics. It cannot take into account road, weather or traffic conditions. The limiter is only an aid. You are responsible for the distance to the vehicle in front, for vehicle speed, for braking in good time and for staying in lane.

You can operate the variable limiter with the cruise control lever. You can store any road speed above 20 km/h. You can also perform settings while the vehicle is stationary if the vehicle has been started.

Kickdown

If you depress the accelerator pedal beyond the pressure point (kickdown), the limiter switches to passive mode. The **Limiter passive** message appears in the multifunction display.

After completion of kickdown, the variable limiter is activated again in the following situations:

- If the driven speed drops below the stored speed.
- If the stored speed is called up.
- If you store a new speed.

Operating cruise control or the variable limiter

⚠ WARNING Risk of accident due to unknown stored speed

If you call up the stored speed and this is lower than your current speed, the vehicle decelerates.

If you do not know the stored speed, the vehicle could decelerate unexpectedly.

- ▶ Take into account the traffic situation before calling up the stored speed.
- ▶ If the stored speed is not known, store the desired speed again.

Change into a lower gear in good time on long and steep downhill gradients. Take particular note of this when driving a laden vehicle. By doing so, you will make use of the braking effect of the engine. This relieves the load on the brake system and prevents the brakes from overheating and wearing too quickly.

Requirements:

Cruise control:

- Cruise control is selected.
- ESP® must be activated, but not intervening.
- The driving speed must be at least 20 km/h.

Variable limiter:

- The vehicle has been started.
- The variable limiter is selected.

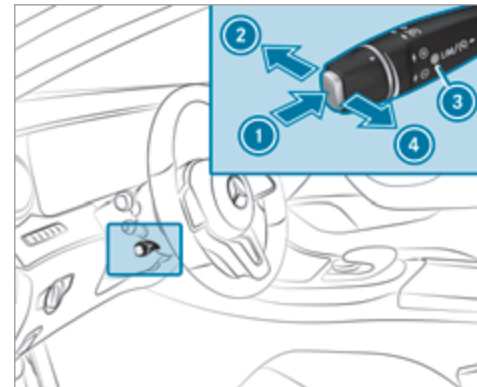

- ▶ To switch between cruise control and variable limiter ①.
 - LIM indicator lamp ③ off: cruise control is selected.
 - LIM indicator lamp ③ on: the variable limiter is selected.
- ▶ Store current speed ④ (once after starting the vehicle).

or

- ▶ Call up last speed stored ④.
- ▶ Deactivate cruise control or variable limiter ②.

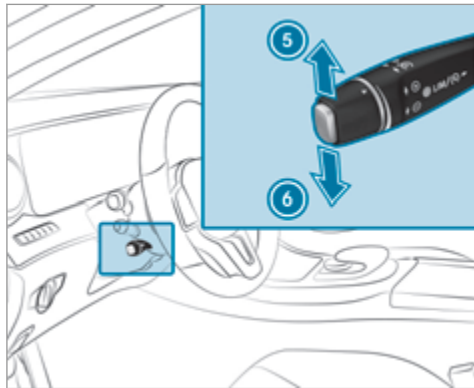

- ▶ Press the lever briefly: the stored speed is increased ⑤ or reduced ⑥ by 1 km/h.

or

- ▶ Press and hold the lever: the stored speed is increased ⑤ or reduced ⑥ in 1 km/h increments.

or

- ▶ Press the lever beyond the pressure point: the stored speed is increased ⑤ or reduced ⑥ by 10 km/h.

or

- ▶ Press and hold the lever beyond the pressure point: the stored speed is increased ⑤ or reduced ⑥ in 10 km/h increments.

If cruise control or the variable limiter has been deactivated, the current speed is stored with ⑤ or ⑥.

- ① Vehicles with manual transmission: if the engine speed is very low, cruise control or the limiter is deactivated. When the engine speed approaches the maximum engine speed, or neutral is engaged or the clutch pedal is depressed for longer than six seconds, cruise control is deactivated.
- ① On vehicles with a segment display in the speedometer, the segments extending from the current stored speed to the end of the

scale light up. If you have activated the permanent limiter and a speed is stored, the segments extending up to the stored speed light up.

- ① If you perform a kickdown, the variable limiter is switched to passive mode. The variable limiter is operational again once the speed drops below the stored speed.
- ① If you brake, deactivate ESP® or if ESP® intervenes, cruise control is deactivated. The variable limiter is not deactivated. When you switch off the vehicle, the last speed stored is cleared.

Permanent limiter

If the vehicle should never exceed a specific speed (e.g. for driving in winter tyre mode), you can set this speed with the permanent limiter.

You do this by limiting the speed to a value between 160 km/h and 240 km/h in the multimedia system (→ page 205).

Shortly before the set speed is reached, it appears in the multifunction display. When you confirm the message with , display messages no longer appear until you switch off the

vehicle. The speed will only be displayed again once the vehicle has been restarted.

The permanent limiter does not switch to passive mode even during kickdown and the driven speed remains below the set speed.

Setting the speed limit for winter tyres

Multimedia system:

➔ Vehicle ➔ Vehicle settings ➔ Limit speed, winter tyres

▶ Select the speed or deactivate the function.

Active Distance Assist DISTRONIC

Function of Active Distance Assist DISTRONIC

Active Distance Assist DISTRONIC

- Maintains the set speed and accelerates or decelerates the vehicle if the distance from the vehicle in front permits.
- Assists you in maintaining the distance from the vehicle in front and can bring your vehicle to a standstill if necessary.

- Brakes your vehicle with up to 50 % of the maximum possible braking power. If greater deceleration performance is required, a visual and acoustic warning is given and you must then intervene yourself.
- **Vehicles with Driving Assistance Package:** responds to stationary vehicles in urban speed ranges (except bicycles, motorcycles and pedestrians) if conditions are sufficient to enable detection.

If you fail to adapt your driving style, Active Distance Assist DISTRONIC can neither reduce the risk of an accident nor override the laws of physics. It cannot take into account road, weather or traffic conditions. Active Distance Assist DISTRONIC is only an aid. You are responsible for the distance to the vehicle in front, for vehicle speed, for braking in good time and for staying in lane.

If all activation conditions are met, you can activate Active Distance Assist DISTRONIC during a journey or while stationary. When Active Distance Assist DISTRONIC is activated, a speed is stored which the driver can increase or reduce

at any time. The speed can be adjusted between 20 km/h and 200 km/h.

Vehicles with the Driving Assistance Package: the speed can be adjusted between 20 km/h and 210 km/h.

Vehicles with the Driving Assistance Package: in conjunction with navigation systems, Active Distance Assist DISTRONIC prevents prohibited overtaking on the right at speeds over 80 km/h in right-hand traffic and overtaking on the left in left-hand traffic on motorways and high-speed major roads.

Active Distance Assist DISTRONIC uses information from the navigation system to respond to certain traffic situations:

- Roundabouts
- T-junctions
- Motorway exits
- Tollbooth

Even if the vehicle in front leaves the detection range in these situations, Active Distance Assist DISTRONIC temporarily maintains the current driving speed and does not accelerate.

If you activate the turn signal indicator to change lanes, the vehicle will accelerate more briskly to the set speed under the following conditions:

- Active Distance Assist DISTRONIC is activated.
- If the driving speed is higher than 70 km/h.
- If the driven speed drops below the stored speed.
- The system cannot detect a vehicle in the relevant area of the overtaking lane.

Drive program

The DYNAMIC SELECT switch allows you to change the driving style of Active Distance Assist DISTRONIC. Depending on which drive program is selected, the driving characteristics can be geared towards fuel economy, comfort or dynamic performance (→ page 170).

System limitations

Active Distance Assist DISTRONIC is active in the 0 km/h to 200 km/h speed range.

Vehicles with the Driving Assistance Package:

Active Distance Assist DISTRONIC is active in the 0 km/h to 210 km/h speed range.

The system may be impaired or may not function in the following instances, for example:

- In snow, rain, fog, heavy spray, if there is glare, in direct sunlight or in greatly varying light conditions.
- The windscreen in the area of the camera is dirty, misted up, damaged or covered.
- If the radar sensors are dirty or covered.
- On slippery roads, braking or accelerating can cause the drive wheels to lose traction and the vehicle could then skid.
- In multi-storey car parks, toll stations or on roads with steep uphill or downhill gradients.

Do not use Active Distance Assist DISTRONIC in these situations.

Tips

Pay particular attention in the following traffic situations. In such situations, brake if necessary. Active Distance Assist DISTRONIC is then deactivated:

- When cornering, entering and exiting a bend.
- When not driving in the centre of the lane.

- When other vehicles are changing lane.
- If there are narrow vehicles.
- If there are obstacles and stationary vehicles.
- If there are crossing vehicles, pedestrians, motorcyclists or cyclists.

Display of Active Distance Assist DISTRONIC in the assistance graphic and in the speedometer



- ① Vehicle ahead
- ② Distance indicator

- ③ Set specified distance
- ④ Own vehicle





- ① Speed of vehicle ahead
- ② Stored speed

Displays in the multifunction display

When activating Active Distance Assist DISTRONIC or when changing the stored speed, the new stored speed is shown for around five seconds in the multifunction display  70 km/h.

When Active Distance Assist DISTRONIC is active, the set stored speed is displayed next to

the  symbol. When distance control is active, the symbol is shown in green.

Vehicles with the Driving Assistance Package: on motorways or high-speed major roads the  symbol is displayed cyclically when the vehicle is ready to pull away.

Operating Active Distance Assist DISTRONIC

⚠ WARNING Risk of accident if the detection function of Active Distance Assist DISTRONIC is impaired

Active Distance Assist DISTRONIC does not react:

- To people or animals.
- To stationary obstacles on the road, e.g. stopped or parked vehicles (vehicles without the Driving Assistance Package).
- To stationary obstacles on the road, e.g. stopped or parked vehicles, if conditions are not sufficient to enable detection (vehicles with the Driving Assistance Package).

- To oncoming vehicles and crossing traffic.

Active Distance Assist DISTRONIC can neither give warnings nor intervene in such situations.

▶ Always carefully observe the traffic conditions and be ready to brake at all times.

⚠ WARNING Risk of accident due to limited detectability of road users and traffic situations

Active Distance Assist DISTRONIC cannot always clearly identify other road users and complex traffic situations.

In these conditions, Active Distance Assist DISTRONIC may:

- Give an unnecessary warning and then brake the vehicle.
- Neither give a warning nor intervene.
- Accelerate or brake unexpectedly.

- ▶ Continue driving with care and be ready to brake, particularly if Active Distance Assist DISTRONIC warns you.

⚠ WARNING Risk of accident from acceleration or braking by Active Distance Assist DISTRONIC

Active Distance Assist DISTRONIC may accelerate or brake in the following cases, for example:

- If the vehicle pulls away using Active Distance Assist DISTRONIC.
- If the stored speed is called up and is considerably faster or slower than the currently driven speed.
- If Active Distance Assist DISTRONIC no longer detects a vehicle in front or does not react to relevant objects.

- ▶ Always carefully observe the traffic conditions and be ready to brake at all times.

- ▶ Take into account the traffic situation before calling up the stored speed.

⚠ WARNING Risk of accident due to insufficient deceleration by Active Distance Assist DISTRONIC

Active Distance Assist DISTRONIC brakes your vehicle with up to 50 % of the maximum possible deceleration. If this deceleration is not sufficient, Active Distance Assist DISTRONIC alerts you with a visual and acoustic warning.

- ▶ In these cases, adjust your speed and keep a sufficient distance.
- ▶ Brake the vehicle yourself and/or take evasive action.

⚠ WARNING Risk of accident due to Active Distance Assist DISTRONIC still being activated when you leave the driver's seat

If you leave the driver's seat while the vehicle is being braked by Active Distance Assist DISTRONIC only, the vehicle can roll away.

- ▶ Always deactivate Active Distance Assist DISTRONIC and secure the vehicle to prevent it from rolling away before you leave the driver's seat.

Requirements:

- The vehicle has been started.
- The electric parking brake is released.
- Active Parking Assist is not being used to park the vehicle or to exit from a parking space.
- ESP® is activated, but is not intervening.
- The transmission is in position **D**.
- The driver's door, front passenger door and the rear doors are closed.
- The bonnet is closed.

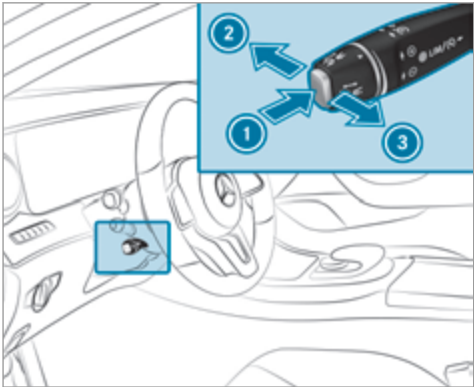

- ▶ If the LIM indicator lamp is lit: select Active Distance Assist DISTRONIC ①.
- ▶ Remove your foot from the accelerator pedal.
- ▶ Store current speed ③. Your vehicle adapts its speed to that of the vehicle in front, but only up to the stored speed.

or

- ▶ Call up stored speed ③.
- ▶ Deactivate Active Distance Assist DISTRONIC ②.

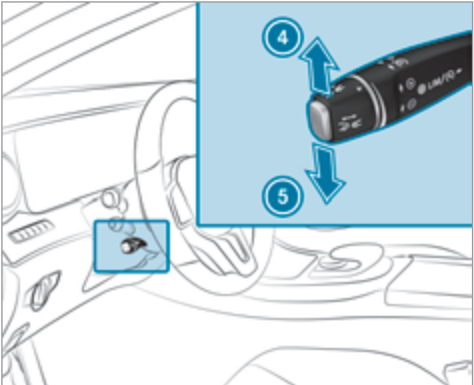

- ▶ Increase ④ or reduce ⑤ the speed.

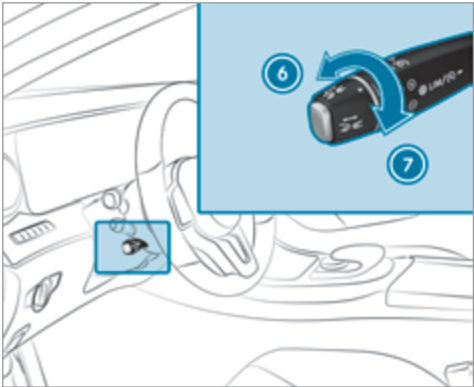

- ▶ Reduce ⑥ or increase ⑦ the specified distance from the vehicle in front.

Pulling away with Active Distance Assist DISTRONIC Requirement

- ▶ A speed has been previously stored.
- ▶ Remove your foot from the brake pedal.

▶ Briefly pull the cruise control lever towards you .

or

▶ Accelerate briefly.
Your vehicle pulls away and adapts its speed to that of the vehicle in front. If no vehicle is detected in front, your vehicle accelerates to the set speed.

Collision warning

If Active Distance Assist DISTRONIC is unable to sufficiently decelerate the vehicle in order to prevent it from approaching the vehicle in front, you will be warned visually and acoustically. An intermittent warning tone will then sound and the distance warning lamp will light up in the instrument cluster.

▶ Brake immediately in order to increase the distance from the vehicle in front.

or

▶ Take evasive action provided it is safe to do so.

Active Steering Assist



Function of Active Steering Assist

Active Steering Assist is only available for vehicles with the Driving Assistance Package.

- Active Steering Assist is operational at speeds up to 210 km/h and helps you to stay in the centre of the lane by means of moderate steering interventions.
- It uses the vehicle in front and the lane markings as a reference depending on the driven speed.
- Active Steering Assist requires you as the driver, to keep your hands on the steering wheel at all times so that you are able to intervene at any time to correct the course of the vehicle and keep it in lane.
- Active Steering Assist can be overridden at any time by steering the vehicle yourself.
- When the system is actively steering, the  symbol is shown in green in the multifunction display.

System limitations of Active Steering Assist

Active Steering Assist has a limited steering torque for lateral guidance. In some cases, the steering intervention is not sufficient to keep the vehicle in the lane.

If the detection of lane markings and vehicles ahead is impaired, Active Steering Assist switches to passive mode. The system provides no support in this case. During the transition from the active to passive status, the  symbol is shown as enlarged and flashes yellow. Once the system is passive the  symbol is shown as grey in the multifunction display.

The system may be impaired or may not function in the following instances:

- If there is poor visibility, e.g. due to insufficient illumination of the road, or due to snow, rain, fog or heavy spray.
- If there is glare, e.g. from oncoming traffic, direct sunlight or reflection from other vehicles (e.g. if the carriageway is wet).
- If the windscreen is dirty, misted up, damaged or covered, for instance by a sticker, in the vicinity of the camera.

- If no, or several, unclear lane markings are present for one lane, e.g. in a construction area.
- If the lane markings are worn away, dark or covered up, e.g. by dirt or snow.
- The distance to the vehicle in front is too small and the lane markings thus cannot be detected.
- If the lane markings change quickly, e.g. lanes branch off, cross one another or merge.
- The carriageway is narrow and winding.
- If there are highly variable shade conditions on the carriageway.
- If there are obstacles such as object markers on the lane or projecting out into the lane.

The system does not provide assistance in the following conditions:

- On very sharp bends.
- When towing a trailer.
- If you actively change lane without switching on the turn signal indicator.

Activating Active Steering Assist

Requirements:

- ESP® must be activated, but not intervening.
- Active Distance Assist DISTRONIC is activated.

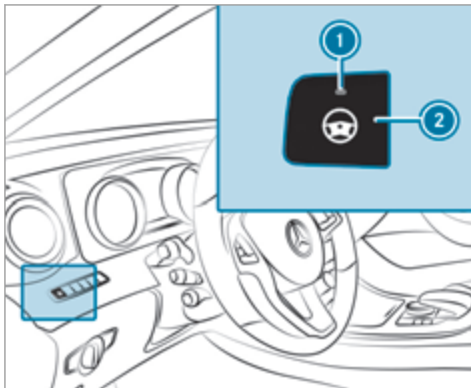

▶ If indicator lamp ① is off: press button ②.

Information on Hill Start Assist

Hill Start Assist holds the vehicle for a short time when pulling away on a hill under the following conditions:

- **Vehicles with automatic transmission:** the transmission is in position **D** or **R**.
- The electric parking brake is released.

This gives you enough time to move your foot from the brake pedal to the accelerator pedal and depress it before the vehicle begins to roll.

⚠ WARNING Risk of accident and injury caused by the vehicle rolling away

After a short time, Hill Start Assist no longer holds the vehicle and it can roll away.

▶ Therefore, swiftly move your foot from the brake pedal to the accelerator pedal. Never attempt to leave the vehicle if it is being held by Hill Start Assist.

HOLD function

HOLD function

The HOLD function holds the vehicle at a standstill without requiring you to depress the brake pedal, e.g. when pulling away on steep slopes.

System limitations

- The incline must not be greater than 30%.

Activating/deactivating the HOLD function

⚠ WARNING Risk of an accident due to the HOLD function being activated when you leave the vehicle

If you leave the vehicle while only the HOLD function is braking the vehicle, the vehicle can roll away in the following situations:

- If there is a malfunction in the system or in the power supply.
- If the HOLD function is deactivated by depressing the accelerator pedal or the brake pedal, e.g. by a vehicle occupant.

- If the electrics in the engine compartment, the battery or the fuses are tampered with or if the battery is disconnected.

▶ Always deactivate the HOLD function and secure the vehicle against rolling away before leaving the vehicle.

! NOTE Damage from automatic braking

When Active Brake Assist, Active Distance Assist DISTRONIC or the HOLD function are activated, the vehicle brakes autonomously in certain situations.

To avoid damage to the vehicle, deactivate these systems in the following or similar situations:

- ▶ During towing
- ▶ In a car wash

Requirements:

- The vehicle is stationary.
- The driver's door is closed or the seat belt on the driver's side is fastened.

- The engine is running or has been automatically switched off by the ECO start/stop function.
- The electric parking brake is released.
- Active Distance Assist DISTRONIC is not activated.
- **Vehicles with automatic transmission:** the transmission is in position **D**, **R** or **N**.

Activating the HOLD function

▶ Depress the brake pedal and after a short time depress further until the **HOLD** display appears in the multifunction display.

▶ Release the brake pedal.

Deactivating the HOLD function

▶ Depress the accelerator pedal to pull away.
or

▶ Depress the brake pedal until the **HOLD** display disappears from the multifunction display.

The HOLD function is deactivated in the following situations:

- When Active Distance Assist DISTRONIC is activated.
- **Vehicles with automatic transmission:** when transmission position **P** is selected.
- When the vehicle is secured with the electric parking brake.

In the following situations, the vehicle is held by the transmission position **P** or by the electric parking brake:

- When the seat belt is unfastened and the driver's door is opened.
- When the engine is switched off.
- When there is a malfunction in the system or if the power supply is insufficient.

Vehicles with manual transmission:

The **Brake immediately** message may also appear in the multifunction display:

- ▶ Immediately depress the brake pedal firmly until the warning message disappears. The HOLD function is deactivated.

A horn sounds at regular intervals if you turn off the engine, remove your seat belt and open the driver's door while the HOLD function is activated. If you attempt to lock the vehicle, the horn tone becomes louder. The vehicle cannot be locked until you have deactivated the HOLD function.

- ⓘ Once you have switched off the engine, you cannot restart the engine until you have deactivated the HOLD function.

DYNAMIC BODY CONTROL

DYNAMIC BODY CONTROL has the following characteristics:

- Variable damping characteristics
- Continual adjustment of the damping forces

The damping characteristics adapt to the current operating and driving situation.

The damping is tuned individually for each wheel and is affected by the following factors:

- The road surface conditions
- Vehicle load

- The drive program selected

The drive program can be adjusted using the DYNAMIC SELECT switch.

AIR BODY CONTROL

AIR BODY CONTROL function

AIR BODY CONTROL is an air suspension system with variable damping for improved driving comfort. The all-round level control system ensures the best possible suspension and constant ground clearance, even with a laden vehicle. When driving at speed, the vehicle is lowered automatically to improve driving safety and to reduce fuel consumption. The option of manually adjusting the vehicle level is also available.

AIR BODY CONTROL comprises:

- Air suspension with variable spring rate
- Automatic level control system
- Speed-dependent lowering to reduce fuel consumption
- Manually selectable high-level setting for greater ground clearance

- ADS PLUS (Adaptive Damping System with constant damping force adjustment)
- DYNAMIC SELECT switch and level button

Available suspension settings

Drive program	Characteristics
C (Comfort)	<ul style="list-style-type: none"> • The suspension tuning is comfortable. • The vehicle is set to the normal level. • When driving at speeds of above 125 km/h the vehicle is lowered. • When driving at speeds below 80 km/h, the vehicle is raised again.
E (Economy)	<ul style="list-style-type: none"> • The suspension tuning is comfortable. • The vehicle is set to the low level. • The vehicle is not lowered any further if you are travelling at higher speeds.
S (Sport)	<ul style="list-style-type: none"> • The suspension tuning is firmer. • The vehicle is set to the low level. • The vehicle is not lowered any further if you are travelling at higher speeds.
S+ (Sport Plus)	<ul style="list-style-type: none"> • The suspension tuning is even firmer. • The vehicle is set to the low level. • The vehicle is not lowered any further if you are travelling at higher speeds.

Setting the vehicle level

⚠ WARNING Risk of accident because vehicle level is too high

If you drive at a higher vehicle level, the driving characteristics may be impaired due to the higher vehicle centre of gravity.

The vehicle can drift outwards, for example, when steering or cornering.

- ▶ Always choose a vehicle level which is suited to the driving style and the road surface conditions.

⚠ WARNING Risk of entrapment from vehicle lowering

When lowering the vehicle, other people could become trapped if their limbs are between the vehicle body and the tyres or underneath the vehicle.

- ▶ Make sure no one is underneath the vehicle or in the immediate vicinity of the wheel arches when you lower the vehicle.

⚠ WARNING Risk of entrapment from vehicle lowering

Vehicles with AIR BODY CONTROL or level control system: When you unload luggage or leave the vehicle, the vehicle first rises slightly and then returns to the set level shortly afterwards.

You or anyone else in the vicinity of the wheel arches or the underbody could thus become trapped.

The vehicle can also be lowered after being locked.

- ▶ When leaving the vehicle, make sure that nobody is in the vicinity of the wheel arches or the underbody.

Requirements:

- The vehicle has been started.
- The vehicle must not be moving faster than 60 km/h.

Raising the vehicle

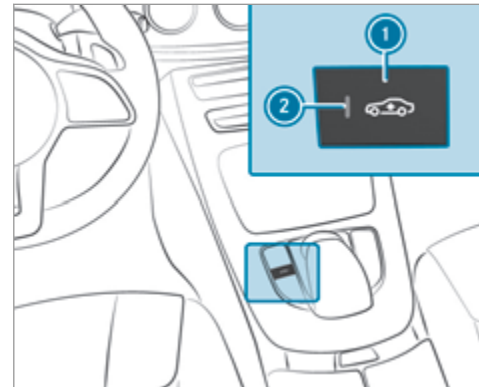

- ▶ Press button ①.
Indicator lamp ② lights up.
The vehicle is set to the high level.

Your selection is saved.

The vehicle is lowered again in the following situations:

- When driving faster than 80 km/h.
- When driving between 60 km/h and 80 km/h for approximately three minutes.
- After selecting a drive program using the DYNAMIC SELECT switch.

The vehicle is adjusted to the height of the last active drive program.

Lowering the vehicle

- ▶ Press button ①. Indicator lamp ② goes out. The vehicle is adjusted to the height of the active drive program.

Parking Assist PARKTRONIC

Function of Parking Assist PARKTRONIC

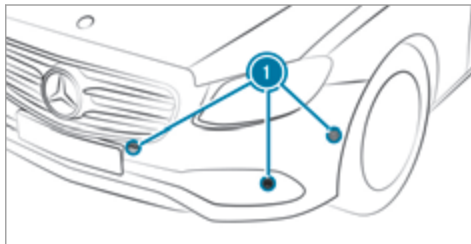

Parking Assist PARKTRONIC is an electronic parking assistance system with ultrasound. It monitors the area around your vehicle using six sensors ① in the front bumper and six sensors in the rear bumper. Parking Assist PARKTRONIC indicates visually and audibly the distance between your vehicle and an object.

Parking Assist PARKTRONIC is only an aid. It is not a substitute for your attention to the surroundings. The responsibility for safe manoeuvring and parking remains with you. Make sure that there are no persons, animals or objects in

the manoeuvring area while manoeuvring and parking in/exiting parking spaces.

In the standard setting, an intermittent warning tone sounds from a distance of approximately 0.3 m to an obstacle. A continuous tone sounds from a distance of approximately 0.2 m. You can set the warning tone in the multimedia system so that it will sound earlier at a greater distance of approximately 1.0 m (→ page 219).

If Parking Assist PARKTRONIC is deactivated, Active Parking Assist is unavailable.

Parking Assist PARKTRONIC display in the multimedia system

If Active Parking Assist is not activated and an obstacle is detected in the path of the vehicle, a pop-up window for Parking Assist PARKTRONIC ① appears in the multimedia system at speeds up to approximately 10 km/h.

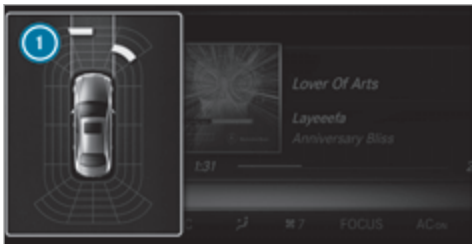

Vehicles with Active Parking Assist without a 360° Camera



Vehicles with Active Parking Assist and a 360° Camera

System limitations

Parking Assist PARKTRONIC does not necessarily take into account the following obstacles:

- Obstacles below the detection range, e.g. persons, animals or objects.
- Obstacles above the detection range, e.g. overhanging loads, overhangs or loading ramps of lorries.

The sensors must be free of dirt, ice and slush. Otherwise, they may not function correctly. Clean the sensors regularly, taking care not to scratch or damage them.

Vehicles with trailer hitch: Parking Assist PARKTRONIC is deactivated for the rear zone when you establish an electrical connection between your vehicle and a trailer.

Function of the passive side impact protection

Passive side impact protection is an additional Parking Assist PARKTRONIC function which warns the driver about obstacles at the side of the vehicle. A warning is issued when obstacles are detected between the front and rear detec-

tion range. In order for an object to be detected, the sensors in the front and rear bumper must detect the object while you are driving past it.

During the parking procedure or manoeuvring, objects are detected as the vehicle drives past. If you steer in the direction of a detected obstacle and there is a risk of a lateral collision, a warning is issued. The lateral segments light up orange or red, depending on the distance to the obstacle.

Segment colour depending on distance

Colour	Lateral distance in cm
Red	Approx. < 30
Orange	Approx 30 - 60

In order for lateral front or rear segments to be displayed, the vehicle must first travel a distance of at least half of the vehicle length. Once the vehicle has travelled the length of the vehicle, all of the lateral front and rear segments can be displayed.

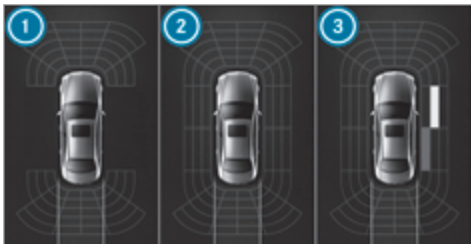

Vehicles without 360° Camera

- ① Parking Assist PARKTRONIC is only operational in the front and rear
- ② Parking Assist PARKTRONIC is operational and can also warn the driver about obstacles at the side of the vehicle
- ③ Obstacle detected at the front right (orange) and rear (red)



Vehicles with 360° Camera

- ① Parking Assist PARKTRONIC is only operational in the front and rear
- ② Parking Assist PARKTRONIC is operational and can also warn the driver about obstacles at the side of the vehicle
- ③ Obstacle detected at the front right (orange) and rear (red)

Saved obstacles are deleted in the following situations, for example:

- You switch off the vehicle
- You open the doors

After the engine is restarted, obstacles must be detected again, before a new warning can be issued.

System limitations

The system limitations for Parking Assist PARKTRONIC apply for passive side impact protection.

The following objects are not detected, for example:

- Pedestrians who approach the vehicle from the side
- Objects placed next to the vehicle

Deactivating/activating PARKTRONIC

! **NOTE** Risk of an accident from objects at close range

Parking Assist PARKTRONIC may not detect certain objects at close range.

- ▶ When parking or manoeuvring the vehicle, pay particular attention to any objects which are above or below the sensors, e.g. flowerpots or drawbars.

The vehicle or other objects could otherwise be damaged.

If indicator lamp **1** is not lit, Parking Assist PARKTRONIC is active. If the indicator lamp is lit or the  symbol appears in the multifunction display, Parking Assist PARKTRONIC is not active.

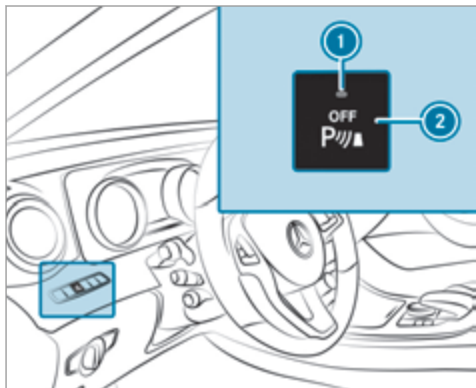

▶ Press button **2**.

- i** Depending on the vehicle's equipment, the button may also be located in the centre console.
- i** Parking Assist PARKTRONIC is automatically activated when the vehicle is started.

Adjusting the warning tones of Parking Assist PARKTRONIC

Multimedia system:

↳ **Vehicle** ▶ **System settings** ▶ **Active Parking Assist** ▶ **Set warning tone**

Adjusting the volume of the warning tones

- ▶ Select **Warning tone volume**.
- ▶ Adjust the value.

Specifying the starting point for the warning tones

You can specify whether the Parking Assist PARKTRONIC warning tones should commence when the vehicle is further away from an obstacle.

- ▶ Select **Warn early**.
- ▶ Activate or deactivate the function.

Activating/deactivating audio fadeout

You can specify whether the volume of a media source in the multimedia system is to be reduced when Parking Assist PARKTRONIC gives an audible warning.

- ▶ Select **Audio fadeout during warning tones**.
- ▶ Activate or deactivate the function.

Reversing camera

Function of the reversing camera

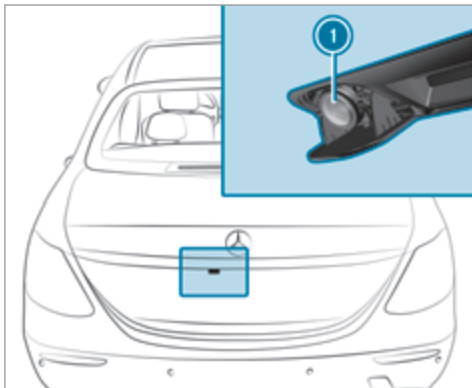

If you have activated the function in the multimedia system, the image from reversing camera ① is displayed in the multimedia system when reverse gear is selected. Dynamic guide lines show the path the vehicle will take with the steering wheel in its current position. This helps

you to orientate yourself and to avoid obstacles when reversing.

The reversing camera is only an aid. It is not a substitute for your attention to the surroundings. The responsibility for safe manoeuvring and parking remains with you. Make sure that there are no persons, animals or objects in the manoeuvring area while manoeuvring and parking in parking spaces.

You can select from the following views:

- Normal view
- Wide-angle view
- Trailer view

The area behind the vehicle is displayed as a mirror image, as in the inside rearview mirror.

System limitations

The reversing camera will not function or will only partially function in the following situations:

- If the boot lid or tailgate is open.
- There is heavy rain, snow or fog.
- The light conditions are poor, e.g. at night.

- The camera lens is obstructed, dirty or misted up. Observe the notes on cleaning the reversing camera (→ page 317).
- The camera or rear of your vehicle is damaged. In this case, have the camera and its position and setting checked at a qualified specialist workshop.

The field of vision and other functions of the reversing camera may be restricted due to additional accessories on the rear of the vehicle (e.g. licence plate bracket or bicycle rack).

- ① The display contrast may be impaired due to incident sunlight or other light sources. In this case, pay particular attention.
- ① If the display operation is considerably impaired due to pixel errors, for example, have the display repaired or replaced.

Vehicles without Active Parking Assist

The following camera views are available in the multimedia system:



Normal view

- ① Yellow guide line, vehicle width (driven surface) depending on the current steering wheel angle (dynamic)
- ② Yellow lane marking the course the tyres will take at the current steering wheel angle (dynamic)
- ③ Yellow guide line at a distance of approximately 1.0 m from the rear area
- ④ Bumper
- ⑤ Red guide line at a distance of approximately 0.3 m from the rear area



Wide-angle view

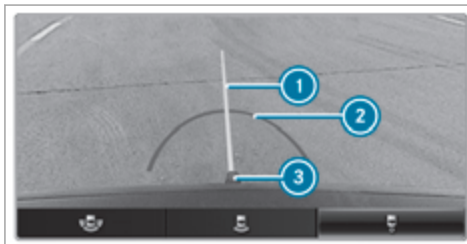

View of trailer (if trailer hitch is fitted)

- ① Yellow guide line, locating aid

- ② Red guide line at a distance of approximately 0.3 m to the ball head of the trailer hitch
- ③ Ball head of the trailer hitch

Vehicles with Active Parking Assist

The following camera views are available in the multimedia system:

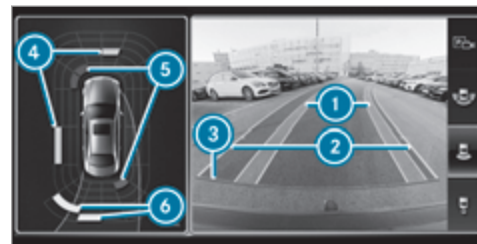

Normal view

- ① Yellow lane marking the course the tyres will take at the current steering wheel angle (dynamic)
- ② Yellow guide line, vehicle width (driven surface) depending on the current steering wheel angle (dynamic)

- ③ Red guide line at a distance of approximately 0.3 m from the rear area
 - ④ Yellow warning display of Parking Assist PARKTRONIC: obstacles are at a distance of between approximately 0.6 m and 1.0 m
 - ⑤ Red warning display of Parking Assist PARKTRONIC: obstacles are very close (approximately 0.3 m or less)
 - ⑥ Orange warning display of Parking Assist PARKTRONIC: obstacles are a medium distance away (between approximately 0.3 m and 0.6 m)
- ⓘ If the entire system fails, the inner segments of the warning display are shown in red. The indicator lamp on the PARKTRONIC button lights up and the  symbol appears in the multifunction display.
- If the system fails at the rear:
- The rear segments are shown in red when reversing.
 - The rear segments are hidden when driving forwards.

When Active Parking Assist is active, the lanes are displayed in green. If Parking Assist PARKTRONIC is deactivated, the warning display fades out.



Wide-angle view

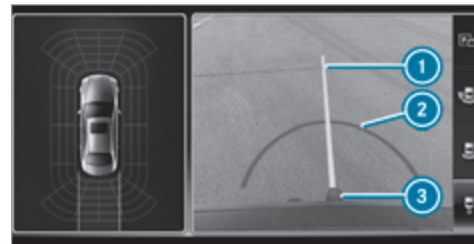

View of trailer (if trailer hitch is fitted)

- ① Yellow guide line, locating aid
- ② Red guide line at a distance of approximately 0.3 m to the ball head of the trailer hitch
- ③ Ball head of the trailer hitch

Switching reversing camera automatic mode on/off

The reversing camera is only an aid. It is not a substitute for your attention to the immediate surroundings. The responsibility for safe manoeuvring and parking remains with you. Make sure that no persons, animals or objects are in the manoeuvring range. Pay attention to

your surroundings and be ready to brake at all times.

Multimedia system:

↳ Vehicle ▶ System settings ▶ Rear view camera ▶ Activation by R gear

- ▶ Activate or deactivate the function. If you have activated the [Activation by R gear](#) function, the image from the reversing camera is displayed in the multimedia system when you select reverse gear.

Opening the camera cover of the reversing camera

Multimedia system:

↳ Vehicle ▶ System settings ▶ Active Parking Assist ▶ Open camera cover

- ▶ Activate or deactivate the function.

360° Camera

Function of the 360° Camera

The 360° Camera is a system that consists of four cameras. The cameras cover the immediate vehicle surroundings. The system supports you,

e.g. when parking or at exits with reduced visibility.

The 360° Camera is only an aid. It is not a substitute for your attention to the surroundings. The responsibility for safe manoeuvring and parking remains with you. Make sure that there are no persons, animals or objects in the manoeuvring area while manoeuvring and parking in parking spaces.

The system evaluates images from the following cameras:

- Reversing camera
- Front camera
- Two side cameras in the outside mirrors

Views of the 360° Camera

You can select from different views:



- ① Wide-angle view, front
- ② Top view with image from the front camera
- ③ Top view with images from the side cameras in the outside mirrors
- ④ Wide-angle view, rear
- ⑤ Top view with image from the reversing camera
- ⑥ Top view with trailer view (if trailer hitch is fitted)

Top view



- ① Lane indicating the route the vehicle will take with the steering wheel in its current position
- ② Yellow warning display of Parking Assist PArkTRONIC: obstacles at a distance of approximately 1.0 m or less
- ③ Your vehicle from above

If the distance to the object lessens, the colour of the warning display changes ②. From a distance of approximately 0.6 m the warning display is shown in orange. From a distance of approximately 0.3 m the warning display is shown in red.

When Parking Assist PArkTRONIC is operational and no object is detected, the segments of the warning display are shown in grey.

- ① If the entire system fails, the segments of the warning display are shown in red. The indicator lamp on the PArkTRONIC button lights up and the  symbol appears in the multifunction display.
- If the system fails at the rear, the display of the segments changes as follows:
- The rear segments are shown in red when reversing.
 - The rear segments are hidden when driving forwards.
- If Parking Assist PArkTRONIC is deactivated, the warning display fades out.

Guide lines



- ① Yellow lane marking the course the tyres will take at the current steering wheel angle (dynamic)
- ② Yellow guide line, vehicle width (driven surface) depending on the current steering wheel angle (dynamic)
- ③ Red guide line at a distance of approximately 0.3 m from the rear area
- ④ Mark at a distance of approx. 1.0 m
- ① When Active Parking Assist is active, the lanes are displayed in green.

The guide lines in the multimedia system display show the distances to your vehicle. The distances only apply to road level. In trailer mode, the guide lines are shown at the level of the trailer hitch.

Trailer view (if trailer hitch is fitted)

If you select trailer view and no trailer is connected to the vehicle, the following display appears:

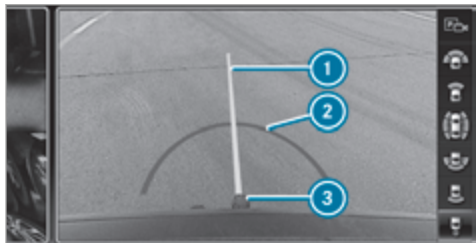

- ① Yellow guide line, locating aid
- ② Red guide line at a distance of approximately 0.3 m to the ball head of the trailer hitch
- ③ Ball head of the trailer hitch



When the electrical connection is established between the vehicle and the trailer, the display changes to side camera view ①.

This view supports manoeuvring procedures with a trailer.

Side view of the mirror cameras

The sides of the vehicle can be seen in this view.

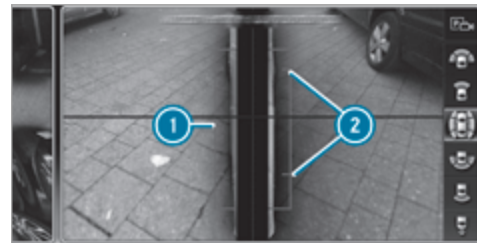

- ① Guide line of external vehicle dimensions with outside mirrors folded out
- ② Marker of the wheel contact points

System limitations

The 360° Camera will not function or will only partially function in the following situations:

- If the doors are open.
- The side mirrors are folded in.
- If the boot lid or tailgate is open.
- There is heavy rain, snow or fog.
- The light conditions are poor, e.g. at night.

- The camera lens is obstructed, dirty or misted up.
- Cameras, or vehicle components in which the cameras are fitted, are damaged. In this event, have the cameras, their positions and their setting checked at a qualified specialist workshop.

Do not use the 360° Camera under such circumstances. You could otherwise injure others or collide with objects when parking the vehicle.

On vehicles with height-adjustable suspension or if the vehicle is carrying a heavy load, leaving the standard height can result in inaccuracies in the guide lines and in the display of the generated images, depending on technical conditions.

The field of vision and other functions of the camera system may be restricted due to additional accessories on the rear of the vehicle (e.g. licence plate bracket, bicycle rack).

See the notes on cleaning the 360° Camera (→ page 317).

Selecting a view for the 360° Camera

The [Activation by R gear](#) function is selected in the multimedia system.

- ▶ Engage reverse gear.
- ▶ In the multimedia system, select the desired view.

Switching automatic mode of the reversing camera on/off (Active Parking Assist)

The reversing camera is only an aid. It is not a substitute for your attention to the surroundings.

The responsibility for safe manoeuvring and parking remains with you. Make sure that no persons, animals or objects etc. are in the manoeuvring range. Pay attention to your surroundings and be ready to brake at all times.

Multimedia system:

↳ [Vehicle](#) ▶ [System settings](#) ▶ [Active Parking Assist](#) ▶ [Activation by R gear](#)

- ▶ Switch the function on or off .
- ▶ If you have activated the [Activation by R gear](#) function, the image from the reversing camera is displayed in the multimedia system when you select reverse gear.

Opening the camera cover of the reversing camera (Active Parking Assist)



Multimedia system:

↳ [Vehicle](#) ▶ [System settings](#) ▶ [Active Parking Assist](#) ▶ [Open camera cover](#)

- ▶ Activate or deactivate the function.

Active Parking Assist

Function of Active Parking Assist

Active Parking Assist is an electronic parking assistance system which uses ultrasound and is automatically activated during forward travel. The system is operational at speeds of up to approximately 35 km/h. When all the conditions are fulfilled, the  symbol appears in the multifunction display and the system automatically searches for and measures parking spaces on both sides of the vehicle parallel and perpendicular to the direction of travel. If Active Parking Assist is activated, suitable parking spaces are displayed in the multimedia system. The  symbol appears in the multifunction display. The arrows show on which side of the carriageway free parking spaces are located.

The parking space and, if necessary, the parking direction can be selected as desired. Active Parking Assist calculates a suitable vehicle path and assists you in parking and exiting the parking space.

Vehicles with automatic transmission: Active Parking Assist changes gear, accelerates, brakes and steers the vehicle.

Vehicles with manual transmission: Active Parking Assist supports you by intervening actively in the steering.

- ① The active brake application and automatic gear change is only available on vehicles with automatic transmission.

Active Parking Assist is only an aid. It is not a substitute for your attention to the surroundings. The responsibility for safe manoeuvring and parking remains with you. Make sure that no persons, animals or objects etc. are in the manoeuvring range.

Active Parking Assist is cancelled if, among other things, one of the following actions is carried out:

- You deactivate Parking Assist PARKTRONIC.

- You deactivate Active Parking Assist.
- You begin steering.
- You apply the parking brake.
- You engage **P**.
- ESP® intervenes.
- You open the tailgate.

System limitations of Active Parking Assist

Objects located above or below the detection range of Active Parking Assist are not detected when the parking space is being measured. These are also not taken into account when the parking manoeuvre is calculated, e.g. overhanging loads, overhangs or loading ramps of lorries or the boundaries of parking spaces. In some circumstances, Active Parking Assist may therefore guide you into the parking space prematurely.

⚠ WARNING Risk of accident due to objects located above or below the detection range of Active Parking Assist

If there are objects above or below the detection range, the following situations may arise:

- Active Parking Assist may steer too early.
- **Vehicles with automatic transmission:** The vehicle may not stop in front of these objects.

This could cause a collision.

- ▶ In these situations, do not use Active Parking Assist.

Snowfall or heavy rain may lead to a parking space being measured inaccurately. Parking spaces that are partially occupied by trailer drawbars might not be identified as such or be measured incorrectly. Only use Active Parking Assist on level, high-grip ground.

Do not use Active Parking Assist in the following situations:

- If you are driving in extreme weather conditions such as ice, packed snow or in heavy rain.
- If you are transporting a load that protrudes beyond the vehicle.
- If the parking space is on a steep downhill or uphill gradient.
- If you have installed snow chains.

Active Parking Assist may also display parking spaces that are not suitable for parking, e.g.:

- Parking spaces where parking is prohibited.
- Parking spaces on unsuitable surfaces.

Active Parking Assist will not assist you with parking spaces at right angles to the direction of travel in the following situations:

- If two parking spaces are located immediately next to each other.
- If the parking space is directly next to a low obstacle such as a low kerb.

Active Parking Assist will not assist you with parking spaces at right angles to the direction of travel in the following situations:

- If the parking space is on a kerb.
- If the parking space is bordered by an obstacle, e.g. a tree, a post or a trailer.

Parking with Active Parking Assist

- ① Depending on the vehicle's equipment, the button may also be located at a different position in the centre console.

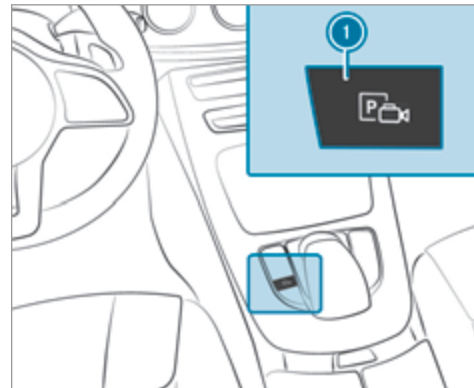

- ▶ Press button ①. The Active Parking Assist view appears on the multimedia system display. Area ② displays detected parking spaces ④ and vehicle path ③.

- ① Vehicle path ③ shown on the multimedia system display may differ from the actual vehicle path.



- ▶ If you have driven past a suitable parking space: bring the vehicle to a standstill.
- ▶ Select desired parking space ④.
- ▶ Where necessary, select the parking direction: forwards or reverse. Vehicle path ③ is shown, depending on the selected parking space and parking direction.
- ▶ Confirm the selected parking space.

⚠ WARNING Risk of accident due to vehicle swinging out while parking or pulling out of a parking space

While parking or exiting a parking space, the vehicle swings out and can drive onto areas of the oncoming lane.

This could cause you to collide with objects or other road users.

- ▶ Pay attention to objects and other road users.
- ▶ Where necessary, stop the vehicle or cancel the parking procedure with Active Parking Assist.

- ▶ If, for example, the **Engage reverse gear** message appears in the multimedia system display: select the corresponding transmission position.

Vehicles with automatic transmission: the vehicle drives into the selected parking space.

- ▶ **Vehicles with manual transmission:** stop as soon as Parking Assist PARKTRONIC

sounds the continuous warning tone, if not before. Depending on the message or as required, engage forward or reverse gear.

On completion of the parking procedure, the **Active Parking Assist finished, take control of the vehicle** display message appears. Further manoeuvring may still be necessary.

- ▶ After completion of the parking procedure, safeguard the vehicle against rolling away. When required by legal requirements or local conditions: turn the wheels towards the kerb.

- ⓘ **Vehicles with automatic transmission:** you can stop the vehicle and change the transmission position during the parking procedure. The system then calculates a new vehicle path. The parking procedure can then be continued. If no new vehicle path is available, the transmission position will be changed again. If the vehicle has not yet reached the parking space, the parking procedure will be cancelled, should a gear be changed.

Exiting a parking space with Active Parking Assist

Requirement:

You can only exit a parking space with Active Parking Assist if you have previously parked the vehicle with Active Parking Assist.

Please note that you are responsible for the vehicle and surroundings during the entire parking procedure.

- ▶ Start the vehicle.

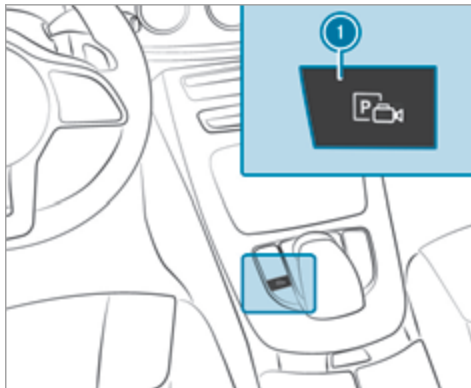

- ▶ Press button ①.
The Active Parking Assist view appears on the multimedia system display.
- ▶ If the vehicle has been parked at right angles to the direction of travel: in area ②, select direction of travel ③.



- ① The vehicle path shown on the multimedia system display may differ from the actual vehicle path.
- ▶ Confirm to start the exiting process.

⚠ WARNING Risk of accident due to vehicle swinging out while parking or pulling out of a parking space

While parking or exiting a parking space, the vehicle swings out and can drive onto areas of the oncoming lane.

This could cause you to collide with objects or other road users.

- ▶ Pay attention to objects and other road users.
- ▶ Where necessary, stop the vehicle or cancel the parking procedure with Active Parking Assist.

- ▶ If, for example, the **Engage forward gear** message appears in the multimedia system display: select the corresponding transmission position.
The vehicle moves out of the parking space.



Example: vehicles with 360° Camera

After the exiting procedure has been completed, the **Active Parking Assist finished, take control of the vehicle.** message appears in the display of the multimedia system. A warning tone and display ④ in the multimedia system prompt you to take over control of the vehicle. You have to accelerate, brake, steer and change gear yourself again.

Function of Remote Parking Assist

- ① Remote Parking Assist is an additional function of Active Parking Assist. Comply with local traffic laws and regulations when using Remote Parking Assist on public roads.

Remote Parking Assist supports the manoeuvring or parking procedure while you are outside your vehicle. Once you have selected a suitable parking space, you then exit the vehicle and guide it into the parking space using a suitable mobile phone. Remote Parking Assist changes gear, accelerates, brakes and steers the vehicle. While Remote Parking Assist is active, the vehicle is locked. You can interrupt the parking process at any time with the mobile phone or the

vehicle key and then take over the vehicle yourself.

You can also use your mobile phone to move your vehicle backwards and forwards in the straight-ahead position (exploration mode). This is useful, for example, if a garage is so narrow that it is difficult or impossible to get in or out of the vehicle after it has been parked. Remote Parking Assist automatically performs any minor steering corrections that are required.

Remote Parking Assist is only an aid. It is not a substitute for your attention to the surroundings. The responsibility for safe manoeuvring and parking remains with you. Interrupt or terminate the parking procedure if necessary. Make sure that no persons, animals or objects etc. are in the manoeuvring range.

For the Remote Parking Assist function, you require a mobile phone and the current Remote Parking Assist App.

The following operating systems are supported:

- Android™
- Apple® iOS

If the connection between the vehicle and the mobile phone is interrupted while a parking manoeuvre is being performed, the manoeuvre can be continued if the connection is re-established within about two minutes.

The following scenarios are supported:

- Parking in a parking space parallel to the direction of travel.
- Parking in a parking space at right angles to the direction of travel.
- Exiting a parking space at right angles to the direction of travel (exploration mode).
- Parking in a straight-ahead position, e.g. into a garage or carport (exploration mode).
- Exiting a parking space in a straight-ahead position, e.g. from a garage or carport (exploration mode).

If a malfunction or a system limitation is detected while parking or manoeuvring (e.g. the permitted downhill gradient is exceeded), the following actions are performed automatically:

- The parking manoeuvre is cancelled.
- The vehicle is brought to a standstill.

- Transmission position **P** is engaged.
- the vehicle is switched off.
- The vehicle remains locked.

If the parking manoeuvre is cancelled, a corresponding message is displayed on the mobile phone. You can then take over and manoeuvre the vehicle into the parking space yourself. Alternatively, you can move the vehicle back to its original position, if necessary.

You can interrupt the parking procedure with Active Parking Assist in order to take control of the vehicle with Remote Parking Assist and manoeuvre it into its final position.

 You can find further information in the operating instructions for the Remote Parking Assist app <http://www.mercedes.me>.

System limitations

Snowfall or heavy rain may lead to a parking space being measured inaccurately or, in certain cases, to connection problems with the mobile phone. Parking spaces that are partially occupied by trailer drawbars might not be identified as such or be measured incorrectly. Only use

Remote Parking Assist on a level, high-grip surface. The parking space must be at least 0.60 m wider than the vehicle without the outside mirrors.

Do not use Remote Parking Assist in the following situations:

- In extreme weather conditions such as ice, packed snow or heavy rain.
- If you are transporting a load that protrudes beyond the vehicle.
- If you have installed snow chains.
- If the parking space is on a downhill or uphill incline.

Remote Parking Assist is cancelled if, among other things, one of the following actions is carried out:

- You deactivate Active Parking Assist.
- You press a button on the key.
- ESP® intervenes.

During the parking procedure, you should not stand more than approx. 3.0 m away from the vehicle. At greater distances, the procedure will

be interrupted and a corresponding message will be displayed on the mobile phone. If you move closer to the vehicle, you will be able to continue the procedure.

Further information on cancelling the function can be found in the operating instructions for the Remote Parking Assist app.

Operating Remote Parking Assist

⚠ WARNING Risk of accident due to objects located above or below the detection range of Active Parking Assist

If there are objects above or below the detection range, the following situations may arise:

- Active Parking Assist may steer too early.
- **Vehicles with automatic transmission:** The vehicle may not stop in front of these objects.

This could cause a collision.

- ▶ In these situations, do not use Active Parking Assist.

Objects located above or below the detection range of the Parking Assist are not detected when the parking space is being measured. These are also not taken into account when the parking manoeuvre is calculated, e.g. overhanging loads, overhangs or loading ramps of lorries or the boundaries of parking spaces. In some circumstances, Parking Assist may therefore guide you into the parking space prematurely.

⚠ WARNING Danger due to insufficient view of the vehicle surroundings

When using the Remote Parking Assist, the view of the vehicle's surroundings may be limited.

- ▶ When you manoeuvre, park or exit a parking space with the vehicle using Remote Parking Assist, observe the following points:
 - Make sure that you have the best view possible of the vehicle and the vehicle's surroundings.
 - Make sure that no persons, animals or objects are in the path of your vehicle.

- Make sure that you maintain a suitable distance to the vehicle and that neither you nor other road users could be endangered.
- Be aware of the vehicle's surroundings at all times and identify possible dangers.
- If necessary, cancel the parking procedure.

Keep in mind that the system limitations must be observed at all times. If necessary, cancel the parking procedure.

Please note that you can only use Remote Parking Assist if you have a valid driving licence and are in a fit state to drive.

During the parking procedure, no persons or pets are allowed in the vehicle.

Always make sure that other road users can access their vehicles.

- ⓘ Keep the key with you during the parking procedure. You can cancel the parking procedure and bring the vehicle to a standstill by pressing a button on the key.

- On completion of the parking procedure, the vehicle is locked.

Requirements:

- The mobile phone and Remote Parking Assist are connected (→ page 236)

Parking

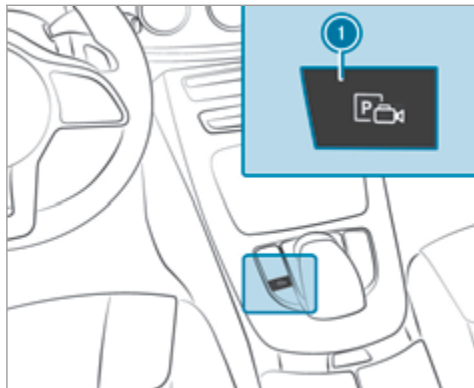

- Press button ①. The Active Parking Assist view appears on the multimedia system display. Area ② displays detected parking spaces ④ and vehicle path ③.

- Vehicle path ③ shown on the multimedia system display may differ from the actual vehicle path.



- If you have driven past a suitable parking space: bring the vehicle to a standstill. Area ② is activated.
- Select transmission position **P**.

- Select the desired parking space in area ② and confirm.
- Exit the vehicle.
- Ensure that all vehicle doors, windows and the boot lid are closed.
- Start the Remote Parking Assist app.
- Observe the instructions of the Remote Parking Assist app accordingly and park the vehicle into the parking space.
- After completion of the parking procedure, safeguard the vehicle against rolling away. When required by legal requirements or local conditions: turn the wheels towards the kerb.

Taking over a parking procedure from Parking Assist

- Park the vehicle with Active Parking Assist (→ page 228).
- When the vehicle is in the desired position, select transmission position **P**. Active Parking Assist is ended and Remote Parking Assist is activated.
- Exit the vehicle.

- ▶ Ensure that all vehicle doors, windows and the boot lid are closed.
- ▶ Start the Remote Parking Assist app.
- ▶ Observe the instructions of the Remote Parking Assist app accordingly and park the vehicle into the parking space.
- ▶ After completion of the parking procedure, safeguard the vehicle against rolling away. When required by legal requirements or local conditions: turn the wheels towards the kerb.

Parking with exploration mode



- ▶ Bring the vehicle to a standstill.

- ▶ Press button ①.
- ▶ The Parking Assist view appears on the multi-media system display. Area ② is activated.
- ▶ To activate Remote Parking Assist, select transmission position **P**.
- ▶ Select your own vehicle ③ and confirm.
- ▶ Exit the vehicle.
- ▶ Ensure that all vehicle doors, windows and the boot lid are closed.
- ▶ Start the Remote Parking Assist app.
- ▶ Observe the instructions of the Remote Parking Assist app accordingly and drive the vehicle forwards or backwards into the desired position.
- ▶ After completion of the parking procedure, safeguard the vehicle against rolling away. When required by legal requirements or local conditions: turn the wheels towards the kerb.

Alternatively, you can proceed as follows:

- ▶ Bring the vehicle to a standstill.
- ▶ Engage transmission position **P** and switch off the vehicle.

- ▶ Exit the vehicle.
- ▶ Start the Remote Parking Assist app.
- ▶ Observe the instructions of the Remote Parking Assist app accordingly and drive the vehicle forwards or backwards into the desired position.
- ▶ After completion of the parking procedure, safeguard the vehicle against rolling away. When required by legal requirements or local conditions: turn the wheels towards the kerb.

The parking procedure requires a minimum parking space size. If clearances get smaller during the parking procedure, e.g. if the vehicle is being driven into a garage, a message appears on the mobile phone. You will need to confirm the reduced clearances.

Exiting a parking space with exploration mode

- ▶ Unlock the vehicle.
- ▶ Start the Remote Parking Assist app within one minute.
- ▶ Observe the instructions of the Remote Parking Assist app accordingly and drive the vehicle.

cle forwards or backwards into the desired position.

- ❗ The outside mirrors are not automatically folded out after exiting a parking space.

Authorising or de-authorising a mobile phone for Remote Parking Assist

Multimedia system:

➔ **Vehicle** ➔ **System settings** ➔ **Active Parking Assist** ➔ **Remote Parking Assist**

Authorising a new mobile phone

In order to be able to use the Remote Parking Assist function, you must authorise your mobile phone. You can authorise up to six mobile phones.

- ▶ Select **Connect new device**. Remote Parking Assist is ready to connect.
- ▶ Start the Remote Parking Assist App and start the authorisation process too. A connection prompt is displayed.
- ▶ Enter the PIN.

De-authorising a mobile phone

- ▶ Select the mobile phone.

- ▶ Select  **Options**.
- ▶ Select **De-authorise**.
- ▶ Select **Yes**.
The mobile phone is deleted from the list of devices.

Function of Drive Away Assist

- ❗ Drive Away Assist is only available for vehicles with automatic transmission.

Drive Away Assist can reduce the severity of an impact when pulling away. If an obstacle is detected in the direction of travel, the vehicle's speed is briefly reduced to approx. 2 km/h. If a critical situation is detected, a symbol appears on the camera image of the multimedia system.

 **WARNING** Risk of accident caused by limited detection performance of Drive Away Assist

Drive Away Assist cannot always clearly identify objects and traffic situations.

In such cases, Drive Away Assist might:

- Warn you without reason and limit the vehicle speed.
 - Not warn you or not limit the vehicle speed.
- ▶ Always pay careful attention to the traffic situation; do not rely on Drive Away Assist alone.
 - ▶ Be prepared to brake or swerve as necessary, provided the traffic situation permits and that it is safe to take evasive action.

Drive Away Assist is only an aid. It is not a substitute for your attention to the surroundings. The responsibility for safe manoeuvring and parking remains with you. Make sure that no persons, animals or objects etc. are in the manoeuvring range.

A risk of a collision may arise in the following situations, for example:

- If the driver mixes up the accelerator and brake pedals.

- If the wrong gear is selected.

The Drive Away Assist function is active under the following conditions:

- If Parking Assist PARKTRONIC is activated.
- Every time the gear is changed to **R** or **D** when the vehicle is at a standstill.
- If the detected obstacle is less than approx. 1.0 m away.
- If the manoeuvring assistance function is activated in the multimedia system.

System limitations

Drive Away Assist is not available on inclines and when driving with a trailer.

Function of Cross Traffic Alert

 Also read the instructions on Blind Spot Assist (→ page 239).

Vehicles with Blind Spot Assist: drivers can also be warned of any crossing traffic when reversing out of a parking space. If a critical situation is detected, a warning symbol appears on the camera image of the multimedia system. If the driver does not respond to the warning, the

vehicle's brakes can be applied automatically. To do this, the function uses the radar sensors in the bumper. The area adjacent to the vehicle is continually monitored.

If the radar sensors are obstructed by vehicles or other objects, detection is not possible.

The Cross Traffic Alert function is active under the following conditions:

- If Blind Spot Assist is activated.
- If the vehicle is reversing at walking pace.
- If the manoeuvring assistance function is activated in the multimedia system.

The Cross Traffic Alert function is not available on inclines and when driving with a trailer.

Deactivating/activating manoeuvring assistance

Multimedia system:

 [Vehicle](#)  [System settings](#)  [Active Parking Assist](#)  [Manoeuvring assistance](#)

 Activate or deactivate the function.

ATTENTION ASSIST

Function of ATTENTION ASSIST

ATTENTION ASSIST assists you on long, monotonous journeys, e.g. on motorways and trunk roads. If ATTENTION ASSIST detects indicators of fatigue or increasing lapses in concentration on the part of the driver, it suggests taking a break.

ATTENTION ASSIST is only an aid. It cannot always detect fatigue or lapses in concentration until too late. The system is not a substitute for a well-rested and attentive driver. On long journeys, take regular breaks in good time that allow for adequate recuperation.

You can choose between two settings.

- **Standard:** normal system sensitivity.
- **Sensitive:** higher system sensitivity. The driver is warned earlier and the attention level detected by ATTENTION ASSIST is adapted accordingly.

If drowsiness or increasing lapses in concentration are detected, the **ATTENTION ASSIST: Take a break!** warning appears in the Instrument Dis-

play. You can acknowledge the message and take a break where necessary. If you do not take a break and ATTENTION ASSIST continues to detect increasing lapses in concentration, you will be warned again after a minimum of 15 minutes.



You can have the following status information for ATTENTION ASSIST displayed in the assistance menu of the on-board computer:

- The length of the journey since the last break.
- The attention level determined by ATTENTION ASSIST.

If ATTENTION ASSIST is unable to calculate the attention level and cannot issue a warning, the **System suspended** message appears.

If ATTENTION ASSIST is deactivated, the  symbol appears in the assistance graphic in the Instrument Display when the engine is running. ATTENTION ASSIST is activated automatically when the engine is re-started. The last selected sensitivity level remains stored.

System limitations

ATTENTION ASSIST is active in the 60 km/h to 200 km/h speed range.

The functionality of ATTENTION ASSIST is restricted, and warnings may be delayed or not occur at all in the following situations:

- If you have been driving for less than 30 minutes.
- If the road condition is poor (uneven road surface or potholes).
- If there is a strong side wind.
- If you adopt a sporty driving style (high cornering speeds or high rates of acceleration).

- If the Steering Assist function of Active Distance Assist DISTRONIC is active.
- If the time has been set incorrectly.
- In active driving situations, if you change lanes and vary your speed frequently.

The ATTENTION ASSIST tiredness or alertness assessment is deleted and restarted when continuing the journey in the following situations:

- If you switch off the engine.
- If you unfasten your seat belt and open the driver's door (e.g. change drivers or take a break).

Activating/deactivating ATTENTION ASSIST

Multimedia system:

[Vehicle](#) ▶ [Assistance](#) ▶ [Attention Assist](#)

Selection options

▶ Select [Standard](#), [Sensitive](#) or [Off](#).

Blind Spot Assist and Active Blind Spot Assist

Function of Blind Spot Assist and Active Blind Spot Assist

Blind Spot Assist uses two lateral, rear-facing radar sensors to monitor the area up to 40 m behind your vehicle and 3 m directly next to your vehicle.

If a vehicle is detected at speeds above approximately 12 km/h and this vehicle subsequently enters the monitoring range directly next to your vehicle, the warning lamp in the outside mirror lights up red.

If a vehicle is detected close to your vehicle in the lateral monitoring range and you switch on the turn signal indicator in the corresponding direction, a warning tone sounds once. The red warning lamp in the outside mirror flashes. If the turn signal indicator remains on, all other detected vehicles are indicated only by the flashing of the red warning lamp.

If you overtake a vehicle quickly, no warning is given.

WARNING Risk of accident despite Blind Spot Assist

Blind Spot Assist does not react to vehicles approaching and overtaking you at a greatly different speed.

As a result, Blind Spot Assist cannot warn drivers in this situation.

 Always pay careful attention to the traffic situation and maintain a safe distance at the side of the vehicle.

Blind Spot Assist and Active Blind Spot Assist are only aids. They may fail to detect some vehicles and are no substitute for attentive driving. Always ensure that there is sufficient distance to the side for other road users and obstacles.

System limitations

The system may be limited in the following situations:

- the sensors are dirty or covered
- poor visibility, e.g. due to fog, heavy rain, snow or spray

- narrow vehicles, e.g. bicycles, are within the monitoring range

Warnings may be issued in error when driving close to crash barriers or similar solid lane borders. Warnings may be interrupted when driving alongside long vehicles, e.g. lorries, for a prolonged time.

Blind Spot Assist is not operational when reverse gear is engaged.

Function of braking applications (Active Blind Spot Assist)

If Active Blind Spot Assist detects a risk of a side impact in the monitoring range, a course-correcting brake application is carried out. This is designed to help you avoid a collision.

The course-correcting brake application is available in the speed range between approximately 30 km/h and 200 km/h.

⚠ WARNING Risk of accident despite brake application of Active Blind Spot Assist

A course-correcting brake application cannot always prevent a collision.

- ▶ Always steer, brake or accelerate yourself, especially if Active Blind Spot Assist warns you or makes a course-correcting brake application.
- ▶ Always maintain a safe distance at the sides.

⚠ WARNING Risk of accident despite Active Blind Spot Assist

Active Blind Spot Assist does not react to the following:

- Overtaking vehicles closely on the side, placing them in the blind spot area.
- Vehicles approaching and overtaking you at a very different speed.

As a result, Active Blind Spot Assist may neither give warnings nor intervene in such situations.

- ▶ Always pay careful attention to the traffic situation and maintain a safe distance at the side of the vehicle.



If a course-correcting brake application occurs, the red warning lamp flashes in the outside mirror and a warning tone sounds. In addition, a display **1** indicating the danger of a side collision appears in the multifunction display.

In rare cases, the system may make an inappropriate brake application. This brake application

may be interrupted at any time if you steer slightly in the opposite direction or accelerate.

System limitations

Either a course-correcting brake application appropriate to the driving situation, or none at all, may occur in the following situations:

- Vehicles or obstacles, e.g. crash barriers, are located on both sides of your vehicle.
- A vehicle approaches too closely on the side.
- You have adopted a sporty driving style with high cornering speeds.
- You brake or accelerate significantly.
- A driving safety system intervenes, such as ESP® or Active Brake Assist.
- ESP® is deactivated.
- A loss of tyre pressure or a defective tyre is detected.
- You are driving with a trailer and the electrical connection to the trailer hitch has been correctly established.

Activating/deactivating Blind Spot Assist or Active Blind Spot Assist

Multimedia system:

↳ Vehicle ▶ Assistance ▶ Blind Spot Assist

▶ Activate or deactivate the function.

Active Lane Keeping Assist

Active Lane Keeping Assist function

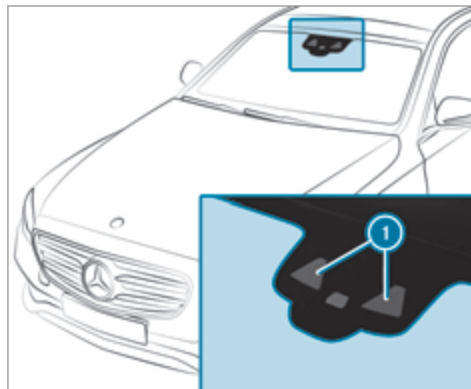

Active Lane Keeping Assist monitors the area in front of your vehicle by means of multifunction camera ①. It serves to protect you against unintentionally leaving your lane. You will be warned by means of a vibration in the steering wheel

and a course-correcting brake application guides you back into your lane.

You are warned by vibration pulses in the steering wheel in the following circumstances:

- Active Lane Keeping Assist detects lane markings.
- A front wheel passes over the lane markings.

You will also be guided back into your lane by means of a course-correcting brake application if the following conditions are met:

- Active Lane Keeping Assist detects lane markings.
- A front wheel drives over a solid lane marking.

Whether a warning is issued and when this occurs also depends on the selected sensitivity setting (standard or adaptive).

If you fail to adapt your driving style, Active Lane Keeping Assist can neither reduce the risk of an accident nor override the laws of physics. It cannot take into account road, weather or traffic conditions. Active Lane Keeping Assist is only an aid. You are responsible for the distance to the

vehicle in front, for vehicle speed, for braking in good time and for staying in lane.

Vehicles with Lane Tracking package: if the lane markings are solid lines and you do not react to the warning, a lane-correcting brake application can bring the vehicle back into the original lane.

Vehicles with Driving Assistance package or Driving Assistance Plus package: if you do not react to the warning, a lane-correcting brake application can bring the vehicle back into the original lane. In the case of a broken lane marking being detected, a brake application will only be made if a vehicle has been detected in the adjacent lane. Oncoming vehicles, overtaking vehicles and vehicles in adjacent lanes can be detected.

The brake application is available in the speed range between 60 km/h and 200 km/h.



If a lane-correcting brake application occurs, display  appears in the multifunction display.

System limitations

No lane-correcting brake application occurs in the following situations:

- You clearly and actively steer, brake or accelerate.
- You have switched on the turn signal indicator.
- A driving safety system intervenes, such as ESP[®], Active Brake Assist or Active Blind Spot Assist.

- You have adopted a sporty driving style with high cornering speeds or high rates of acceleration.
- ESP[®] is deactivated.
- When driving with a trailer, the electrical connection to the trailer has been correctly established.
- If a loss of tyre pressure or a defective tyre has been detected and displayed.

The system may be impaired or may not function in the following situations:

- If there is poor visibility, e.g. due to insufficient illumination of the road, highly variable shade conditions, or due to rain, snow, fog or heavy spray.
- There is glare, e.g. from oncoming traffic, the sun or reflections.
- If there is dirt on the windscreen in the vicinity of the multifunction camera or the camera is misted up, damaged or obscured.
- No or several, unclear lane markings are present for one lane, e.g. near roadworks.
- The lane markings are worn, dark or covered.

- The distance to the vehicle in front is too small and the lane markings thus cannot be detected.
- The lane markings change quickly, e.g. lanes branch off, cross one another or merge.
- The carriageway is very narrow and winding.

Vehicles with Driving Assistance package or Driving Assistance Plus package: Active Lane Keeping Assist uses radar sensors to monitor several areas around the vehicle. If the radar sensors in the rear bumper are dirty or covered with snow, the system may be impaired or may not function. If an obstacle in the lane in which you are driving has been detected, no lane-correcting brake application occurs.

Activating Active Lane Keeping Assist

⚠ WARNING Risk of accident despite Active Lane Keeping Assist warning

A lane-correcting brake application cannot always bring the vehicle back into the original lane.

▶ Always steer, brake or accelerate yourself, especially if Active Lane Keeping Assist warns you or makes a lane-correcting brake application.

⚠ WARNING Risk of accident despite intervention of Active Lane Keeping Assist

Active Lane Keeping Assist does not detect traffic conditions or road users. In very rare cases, the system may make an inappropriate brake application, e.g. after intentionally driving over a solid lane marking.

The brake application can be interrupted at any time if you steer slightly in the opposite direction.

▶ Always make sure that there is sufficient distance to the side for other traffic or obstacles.

⚠ WARNING Risk of accident despite Lane Keeping Assist

Lane Keeping Assist cannot always clearly detect lane markings.

In such cases, Lane Keeping Assist can:

- give an unnecessary warning
- not give a warning

▶ Always pay particular attention to the traffic situation and keep within the lane, especially if Active Lane Keeping Assist alerts you.

Requirement:

The driving speed is at least 60 km/h.

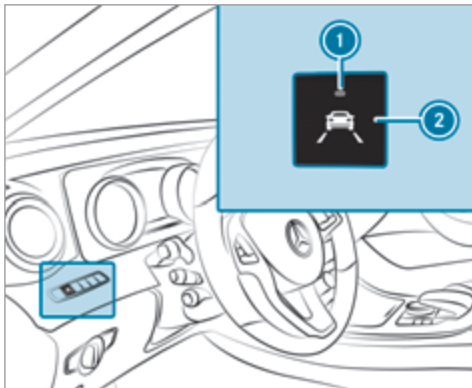

- ▶ Press button ②.
If indicator lamp ① lights up, Lane Keeping Assist is activated. When lane markings are detected, the lines in the assistance graphic are shown in white.

Sensitivity of Active Lane Keeping Assist

With the standard or adaptive setting, you can influence when the warning vibration of Lane Keeping Assist takes place.

In both the standard and adaptive settings, no warning vibration occurs in the following situations:

- You have switched on the turn signal indicator.
- A driving safety system intervenes, such as ABS, BAS or ESP®.

In the adaptive setting, there will also be no warning vibration in the following situations:

- The vehicle is accelerated or braked considerably.
- You steer actively, e.g. swerve to avoid an obstacle or change lane quickly.
- You cut the corner on a sharp bend.

Setting the sensitivity of Active Lane Keeping Assist

Multimedia system:

↳ [Vehicle](#) ▶ [Assistance](#) ▶ [Active Lane Keeping Assist](#)

Selection options

- ▶ Select [Adaptive](#) or [Standard](#).

Trailer hitch

Trailer operation notes

Mercedes-AMG vehicles: always observe the notes in the Supplement. Otherwise, you may fail to recognise dangers.

Observe the following notes on the tongue weight:

- use a tongue weight as close as possible to the maximum tongue weight
- do not use a tongue weight that exceeds or falls below the permissible tongue weight

Do not exceed the following values:

- the permissible towing capacity
- the permissible rear axle load of the towing vehicle
- the permissible gross mass of the towing vehicle
- the permissible gross mass of the trailer
- the maximum permissible speed of the trailer

Make sure of the following before starting a journey:

- the tyre pressure on the rear axle of the towing vehicle is set for a maximum load
- the lighting of the connected trailer is operational
- **Vehicles without LED headlamps or MULTIBEAM LED headlamps:** The headlamps have been set correctly.

In the event of increased rear axle load, the car/trailer combination may not exceed a maximum speed of 100 km/h for reasons concerning the operating permit. This also applies in countries in which the permissible maximum speed for car/trailer combinations is above 100 km/h.

Extending/retracting the ball neck fully electrically

⚠ WARNING Risk of accident due to the ball neck not being engaged

If the ball neck is not engaged, the trailer may come loose.

▶ Make sure that the ball neck securely engages and locks into place.

! **NOTE** Damage to the fully-electric trailer hitch

The fully-electric trailer hitch could be mechanically damaged by applying additional pressure when the ball neck is being extended or retracted.

▶ Do not make the ball neck extend/retract faster by applying additional pressure.

Requirements:

Make sure of the following before extending/retracting the ball neck fully electrically:

- Shift the transmission to position **P** or **N**.
- The range of movement is clear.
- **Only when retracting:** remove the trailer cables or adapter plugs.

Extending/retracting the ball neck fully electrically

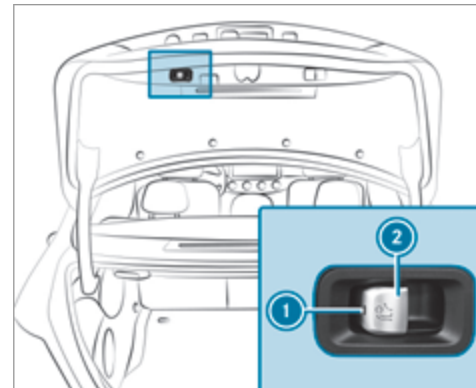

- ▶ Pull switch **2**. Indicator lamp **1** flashes and the **Trailer coupling extending...** display message appears on the multifunction display. The ball neck extends fully electrically.

- ▶ Wait until the ball neck has locked in place. The ball neck is securely locked in place when indicator lamp ① lights up continuously.

If the ball neck is not securely locked in place, indicator lamp ① flashes and the **Check trailer hitch lock** display message appears on the multifunction display.

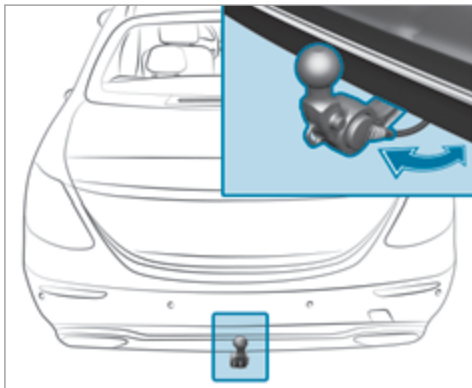

- ▶ Pull switch ②. Indicator lamp ① flashes and the **Trailer coupling extending...** display message appears on the multifunction display. The ball neck retracts fully electrically.
- ▶ Wait until the ball neck has locked in place. The ball neck is securely locked into place once indicator lamp ① goes out. If the ball neck is not securely locked in place, indicator lamp ① flashes and the **Check trailer hitch lock** display message appears on the multifunction display.

Observe the information on the displays in the instrument cluster:

- Warning and indicator lamps (→ page 438)
- Display messages (→ page 381)

Coupling up/uncoupling a trailer

⚠ WARNING Risk of injury from the vehicle level being changed

Vehicles with level control system: the vehicle level may be changed unintentionally, e.g. by other persons. You may become trapped if you couple up or uncouple a trailer while the vehicle level is changing. In addition, other people could become trapped if their limbs are between the vehicle body and the tyres or underneath the vehicle.

When coupling up or uncoupling a trailer, make sure that:

- ▶ The doors or tailgate are not opened or closed.
- ▶ Do not initiate the level control system and do not operate the DYNAMIC SELECT switch.
- ▶ The vehicle is not locked or unlocked.

Requirements:

- the ball neck must be extended fully electrically and engaged in the securely locked position.

Trailers with a 7-pin plug can be connected to the vehicle with the following adapters:

- adapter plug
- adapter cable

The trailer will be correctly detected by the vehicle only if the following conditions are met:

- the trailer is connected correctly
- the trailer lighting system is in working order

The operation of the following systems depends on the trailer being connected correctly:

- Active Lane Keeping Assist
- ESP®
- Parking Assist PARKTRONIC
- Active Parking Assist
- Blind Spot Assist or Active Blind Spot Assist

Coupling up a trailer

1 NOTE Damage to the battery due to full discharge

Charging the trailer battery using the power supply of the trailer can damage the battery.

▶ Do not use the power supply to charge the trailer battery.

- ▶ Remove the cover from the ball head and store it in a safe place (→ page 107).
- ▶ Position the trailer on a level surface behind the vehicle and couple it up to the vehicle.



- ▶ Open the socket cover.
- ▶ Insert the plug connector with lug ① into groove ③ on the socket.
- ▶ Turn bayonet coupling ② clockwise as far as it will go.
- ▶ Let the cover engage.
- ▶ Secure the cable to the trailer with cable ties (if you are using an adapter cable).
- ▶ Make sure that cable is always slack for ease of movement during cornering.
- ▶ Push the combination switch upwards and downwards and check whether the corresponding turn signal light on the trailer is flashing.

A display message may appear on the multifunction display even if the trailer has been connected correctly:

- LEDs have been installed on the trailer lighting system
- the current has fallen below the trailer lighting system's minimum current (50 mA)

-  Accessories can be connected to the permanent power supply up to 180 W, and to the power supply that is switched on via the ignition lock.

Uncoupling a trailer

-  **WARNING** Risk of being crushed and becoming trapped when uncoupling a trailer

When uncoupling a trailer with an engaged inertia-activated brake, your hand may become trapped between the vehicle and the trailer drawbar.

-  Do not uncouple trailers with an engaged overrun brake.

-  **WARNING** Risk of becoming trapped when disconnecting the trailer cable

Vehicles with level control system: the vehicle lowers when the trailer cable is disconnected.

This could result in you or other people becoming trapped if your or their limbs are between the vehicle body and the tyres or underneath the vehicle.



-  Make sure nobody is underneath the vehicle or in the immediate vicinity of the wheel arches when you disconnect the trailer cable.

-  **NOTE** Damage to the rear bumper from installing adapter cables or adapter plugs

The following parts could be damaged when retracting the ball neck fully electrically:

- bumper
 - adapter cable
 - adapter plug
-  Always remove the adapter cable or adapter plug before retracting the ball neck fully electrically.

-  Safeguard the trailer against rolling away.

-  Disconnect the electrical connection between the vehicle and the trailer.
-  Uncouple the trailer.
-  Place the cover on the ball head.

Bicycle rack

-  **WARNING** Risk of an accident when using the bicycle rack incorrectly

The bicycle rack may become detached from the vehicle in the following cases:

- the permissible load capacity of the trailer hitch is exceeded.
- the bicycle rack is used incorrectly.
- the bicycle rack is secured to the ball neck beneath the ball head.

Observe the following for your own safety and that of other road users:

- always adhere to the permissible load capacity of the trailer hitch.

- only use the bicycle rack to transport bicycles.
- always mount the bicycle rack properly by attaching to the ball head and the ball neck guide pin, if possible.
- when transporting four bicycles, always use bicycle racks which have additional support on the ball neck guide pin.
- only use bicycle racks approved by Mercedes-Benz.
- always observe the bicycle rack operating instructions.

! **NOTE** Damage to or cracks on the trailer hitch due to unsuitable bicycle racks or bicycle racks being used incorrectly

▶ Only use bicycle racks approved by Mercedes-Benz.

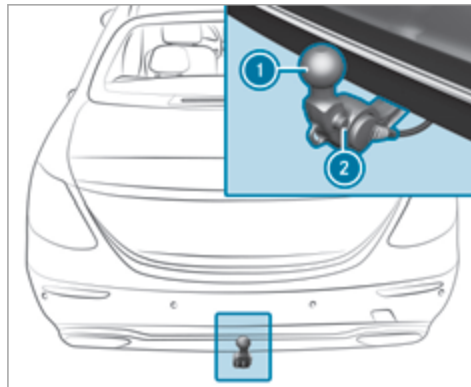

Trailer hitch (example with additional guide pins)

Depending on the design, up to four bicycles can be transported on the bicycle rack:

- when mounted by attaching to ball head ①, the maximum load capacity is 75 kg. Up to three bicycles can be transported.

- when mounted on ball head ① and guide pin ②, the maximum load capacity is 100 kg. Up to four bicycles can be transported.

The load capacity is calculated from the weight of the bicycle rack and the bicycle rack load.

For bicycles weighing a total of between 75 kg and 100 kg only use bicycle racks with additional support on guide pin ②.

The vehicle's handling characteristics change when a bicycle rack is fitted. The vehicle:

- is heavier
- is restricted in its acceleration -and slope climbing ability.
- has an increased braking distance

This can impair the vehicle's handling characteristics. Adapt your driving style accordingly. Drive carefully and maintain a safe distance.

When using a bicycle rack, set the tyre pressure for maximum load on the rear axle of the vehicle. Further information on the tyre pressure can be found in the tyre pressure table (→ page 346).

Notes on loads

The larger the distance between the load's centre of gravity and the ball head, the greater the load on the trailer hitch.

Observe the following notes:

- mount heavy bicycles as close to the vehicle as possible.
- always distribute the load on the bicycle rack as evenly as possible across the vehicle's longitudinal axis.

Mercedes-Benz recommends removing all detachable parts from the bicycles, e.g. baskets, child seats or rechargeable batteries, before loading them onto the bicycle rack. This improves the wind resistance and centre of gravity of the bicycle rack.

Always secure the bicycles to prevent them from moving around and check they are secured at regular intervals.

Do not use tarpaulins or other covers. The handling characteristics and rear view may be

impaired. In addition, the wind resistance and load on the trailer hitch increase.

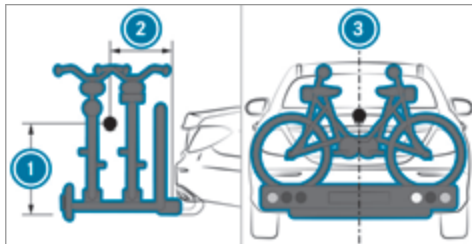

Distribution of the load on the bicycle rack

- ① Vertical distance between the centre of gravity and ball head
- ② Horizontal distance between centre of gravity and ball head
- ③ The centre of gravity is on the vehicle's central axis

Observe the following information when loading the bicycle rack:

Number of bicycles	Total weight of bicycle and load	Max. distance ①	Max. distance ②
3	Up to 75 kg	420 mm	300 mm
4 ¹	Up to 90 kg ¹	420 mm	400 mm
4 ¹	Up to 100 kg ¹	420 mm	400 mm

¹ When transporting four bicycles or with a total weight between 75 kg and 100 kg, always use bicycle racks with additional support on the trailer hitch guide pin.

¹ When transporting four bicycles or with a total weight between 75 kg and 100 kg, always use bicycle racks with additional support on the trailer hitch guide pin.

Instrument display overview

Mercedes-AMG vehicles: be sure to observe the notes in the Supplement. Otherwise, you may fail to recognise dangers.

⚠ WARNING Risk of accident due to an instrument display malfunction

If the instrument display has failed or malfunctioned, you may not recognise function restrictions applying to safety relevant systems.

The operating safety of your vehicle may be impaired.

- ▶ Drive on carefully.
- ▶ Have the vehicle checked immediately at a qualified specialist workshop.

If the operating safety of your vehicle is impaired, park the vehicle safely as soon as possible. Contact a qualified specialist workshop.

Instrument display (standard)



- ① Speedometer
- ② Multifunction display
- ③ Rev counter
- ④ Coolant temperature display
- ⑤ Fuel level and fuel filler flap location indicator

Instrument display in the widescreen cockpit

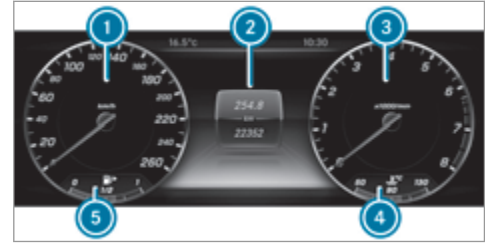

- ① Speedometer
- ② Multifunction display
- ③ Example: area for additional values
- ④ Coolant temperature display
- ⑤ Fuel level and fuel filler flap location indicator

ⓘ Further display content can be shown in display ③ for additional values (→ page 254).

The segments in speedometer ① indicate the system status for the following:

- Cruise control (→ page 201)

- Limiter (→ page 202)
- Active Distance Assist DISTRONIC (→ page 205)

! **NOTE** Engine damage due to excessively high engine speeds

The engine will be damaged if you drive with the engine in the overrevving range.

- ▶ Do not drive with the engine in the overrevving range.

The fuel supply is interrupted to protect the engine when the red band in rev counter **③** (overrevving range) is reached.

During normal operating conditions, coolant temperature display **④** may rise to 120 °C.

! **WARNING** Danger of burns when opening the bonnet

If you open the engine bonnet when the engine has overheated or during a fire in the engine compartment, you could come into contact with hot gases or other escaping operating fluids.

- ▶ Before opening the bonnet, allow the engine to cool down.
- ▶ In the event of a fire in the engine compartment, keep the engine bonnet closed and call the fire service.

Vehicles with a 48 V on-board electrical system (EQ Boost technology):



- E-POWER **①** shows the electrical drive support as a percentage.
- CHARGE **②** shows the electric motor's recuperation performance as a percentage.

READY shows the drive system's operational readiness .

Overview of the buttons on the steering wheel







① Button group:

- Main menu and back button (on-board computer)
- Switches sound off/on
- Increases the volume
- Decreases the volume

- ② Touch Control (on-board computer)
- ③ Touch Control (multimedia system)

④ Button group:

-  Main menu and back button (multimedia system)
-  LINGUATRONIC or voice control system
-  Makes/accepts a call
-  Rejects/ends a call

Operating the on-board computer

⚠ WARNING Risk of distraction from information systems and communications equipment

If you operate information and communication equipment integrated in the vehicle when driving, you will be distracted from the traffic situation. This could also cause you to lose control of the vehicle.

- ▶ Only operate this equipment when the traffic situation permits.
- ▶ If you cannot be sure of this, stop the vehicle whilst paying attention to road

and traffic conditions and operate the equipment with the vehicle stationary.

You must observe the legal requirements for the country in which you are currently driving when operating the on-board computer.

- ① The on-board computer displays appear on the multifunction display (→ page 255).



The on-board computer can be operated using Touch Control ② and back button ① on the left-hand side of the steering wheel.

Different acoustic signals provide feedback when operating the on-board computer, e.g:

- reaching the end of a list
- scrolling through a list

The following menus are available:

- [Service](#)
- [Assistance](#)
- [Trip](#)
- [Navigation](#)
- [Radio](#)
- [Media](#)
- [Telephone](#)
- [HUD](#)
- **Vehicles with an instrument display in the widescreen cockpit:** [Design](#)

The menus can be called up from the menu bar on the multifunction display.



- ▶ **To call up the menu bar:** press the back button on the left ①.
- ▶ **To scroll in the menu bar:** swipe to the left or right on the left-hand Touch Control ②.
- ▶ **To call up the menu or confirm the selection:** press the left-hand Touch Control ②.
- ▶ **To scroll through displays or lists on the menu:** swipe upwards or downwards on the left-hand Touch Control ②.
- ▶ **To call up a submenu or confirm the selection:** press the left-hand Touch Control ②.

- ▶ **To exit a submenu:** press the back button on the left ①.

If you are browsing a submenu and you press and hold the back button on the left ①, the menu bar appears.

Setting the additional value range



Example: G-Meter

- ① Additional value range
- ② Index points

- ▶ **To select display content:** swipe to the right on the left-hand Touch Control.

- ▶ Swipe upwards or downwards on the left-hand Touch Control to select display content. When display content is selected, the additional value range ① is briefly highlighted. The index points ② display the selected list item.

The following display content can be selected in the **Classic** and **Sport** designs:

- Rev counter
- Navigation
- ECO display
- Consumption
- G-Meter

The following content can be selected in the **Progressive** design:

- Date
- Navigation
- ECO display
- Consumption
- G-Meter

Overview of displays on the multifunction display

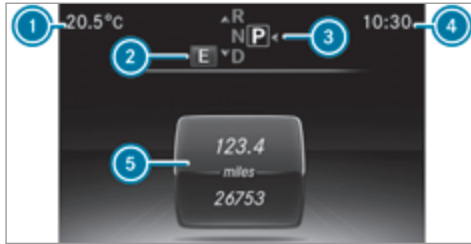

- ① Outside temperature
- ② Drive program
- ③ Transmission position
- ④ Time
- ⑤ Display section

① **Vehicles with the Instrument Display in the Widescreen Cockpit:** the position of the displays deviates from those displayed here.

Further displays on the multifunction display:

- ↑ Gearshift recommendation (→ page 174)
- Active Parking Assist activated (→ page 228)
- Parking Assist PARKTRONIC deactivated (→ page 218)
- Cruise control (→ page 201)
- Limiter (→ page 202)
- Active Distance Assist DISTRONIC (→ page 205)
- Active Steering Assist (→ page 210)
- ECO start/stop function (→ page 166)
- HOLD function (→ page 212)
- Adaptive Highbeam Assist (→ page 132)
- Adaptive Highbeam Assist Plus (→ page 134)
- Maximum permissible speed exceeded (for certain countries only)

Adjusting the instrument lighting

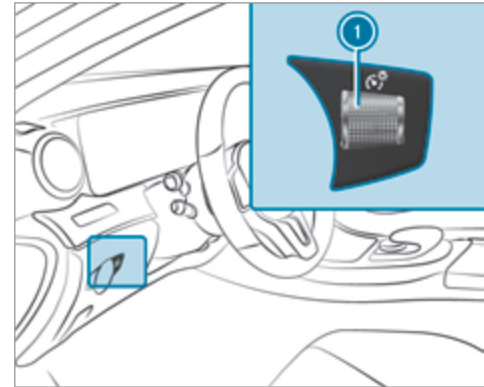

- ▶ Turn brightness control ① up or down. The lighting of the instrument display and in the control elements in the vehicle interior is adjusted.

Menus and submenus

Functions on the Service menu of the on-board computer

On-board computer:

↳ Service

▶ **To select the function:** swipe upwards or downwards on the left-hand touch control.

▶ Press the left-hand touch control.

Functions on the **Service** menu:

- Message memory (→ page 381)
- **AdBlue:** Adblue® range
- **Tyres:**
 - Restarting the tyre pressure loss warning system (→ page 352)
 - Checking tyre pressure with the tyre pressure monitoring system (→ page 348)
 - Restarting the tyre pressure monitoring system (→ page 348)
- **ASSYST PLUS:** Calling up the service due date (→ page 306)

- Engine oil level

Calling up the assistant display

On-board computer:

↳ Assistance

❗ **Vehicles with the instrument display in the widescreen cockpit:** when you have the design set to **Progressive**, you can view the assistant display in the left-hand portion of the instrument display.



The following displays are available from the assistant display menu:

- Assistant display
- Attention level (→ page 237)

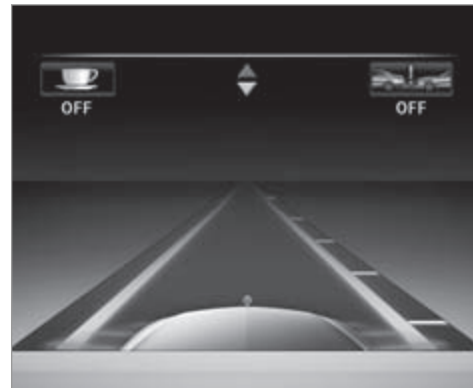
▶ **To switch between the displays:** swipe upwards or downwards on the left-hand touch control.



Status displays on the assistant display:

- : ATTENTION ASSIST deactivated
- : Active Brake Assist deactivated
- Light lane markings: Active Lane Keeping Assist activated
- Green lane markings: Active Lane Keeping Assist active

- Grey radar waves next to vehicle: Blind Spot Assist activated
- Green radar waves next to vehicle: Blind Spot Assist active
- Active Distance Assist DISTRONIC displays (→ page 205)

Calling up displays in the Trip menu

On-board computer:



Trip

- ① **Vehicles with an instrument display in the widescreen cockpit:** when you have the design set to **Progressive**, you can view information on the journey in the left-hand area of the instrument display.

▶ **To select a display:** swipe upwards or downwards on the left-hand Touch Control.

Displays in the **Trip** menu:

- standard display
- range and current fuel consumption

When gliding mode is active (→ page 175), **Gliding mode** is displayed instead of the current fuel consumption.

A recuperation display is also available for certain engines. If there is only a small amount of fuel left in the fuel tank, the display shows a vehicle being refuelled instead of the range.

- ECO display (→ page 168)
 - Trip computer **From start** and **From reset**
 - Digital speedometer
- ① **Vehicles with an Instrument Display in the Widescreen Cockpit:** the digital speedometer only appears in the **Classic** and **Sport** designs.



Example: standard display

- ① Trip distance
- ② Total distance recorder



Example: trip computer

- ① Total distance recorder
- ② Driving time
- ③ Average speed
- ④ Average fuel consumption

① **Vehicles with certain engines:** the emission-free trip distance and driving time are also displayed.

Resetting values on the Trip menu of the on-board computer

On-board computer:



① The spelling may differ in the main menu displayed. Therefore, observe the menu overview for the instrument display (→ page 253).

You can reset the values of the following functions:

- Trip distance
- Trip computer **From start** and **From reset**
- ECO display (→ page 168)

▶ **To select the function to be reset:** swipe upwards or downwards on the left-hand touch control.

▶ Press the left-hand touch control.

▶ Select **Yes**.

▶ Press the left-hand touch control.

If you press and hold the left-hand touch control, the function will be reset immediately.

Calling up navigation instructions in the on-board computer

On-board computer:

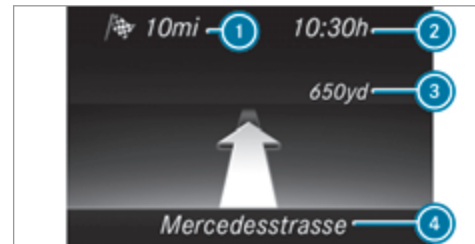

Example: no change of direction announced

- ① Distance to the next destination
- ② Estimated arrival time
- ③ Distance to the next change of direction
- ④ Current road



Example: change of direction announced

- ① Road to which the change of direction leads
- ② Distance to the change of direction
- ③ Change-of-direction symbol
- ④ Recommended lane and new lane during a change of direction (white)
- ⑤ Possible lane
- ⑥ Lane not recommended (dark grey)

Further possible displays on the [Navigation](#) menu:

- **Direction of travel:** display of direction of travel and road currently being travelled on.

- **New route...** or **Calculating route...:** a new route is calculated.
 - **Road not mapped:** the road is unknown, e.g. for newly built roads.
 - **No route:** no route could be calculated to the selected destination.
 - **Off map:** the map for the current location is not available.
 - **Area of destination reached:** you have reached the area of destination.
 - : you have reached the destination or an intermediate destination.
- ▶ **To exit the menu:** press the back button on the left.

Selecting radio stations using the on-board computer

On-board computer:

➔ Radio



- ① Frequency range
- ② Station
- ③ Name of track
- ④ Name of artist

When you select a station in the memory presets, the preset appears next to the station name. When you select a saved station in the frequency range, an asterisk appears next to the station name.

- ▶ **To select a radio station:** swipe upwards or downwards on the left-hand touch control.

Selecting the frequency range or station preset

- ▶ Press the left-hand touch control.
- ▶ **To select the frequency range/station preset:** swipe upwards or downwards on the left-hand touch control.
- ▶ Press the left-hand touch control.

Media playback using the on-board computer

On-board computer:

↳ Media

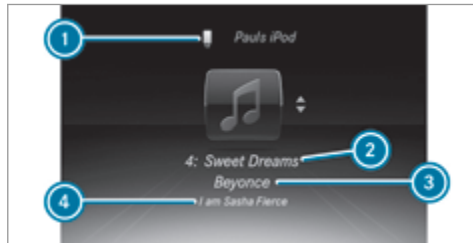

- ① Media source
- ② Current track and track number
- ③ Name of artist (example)
- ④ Name of album

The folder name also appears on the display.

- ▶ **To change tracks on an active media source:** swipe upwards or downwards on the left-hand touch control.

Changing a media source

- ▶ Press the left-hand touch control.
- ▶ **To select a media source:** swipe upwards or downwards on the left-hand touch control.
- ▶ Press the left-hand touch control.

Dialling telephone numbers using the on-board computer

Requirements:

- The mobile phone is connected to the multi-media system.

On-board computer:

↳ Telephone

⚠ WARNING Risk of distraction from information systems and communications equipment

If you operate information and communication equipment integrated in the vehicle when driving, you will be distracted from the traffic situation. This could also cause you to lose control of the vehicle.

- ▶ Only operate this equipment when the traffic situation permits.
- ▶ If you cannot be sure of this, stop the vehicle whilst paying attention to road and traffic conditions and operate the equipment with the vehicle stationary.

When telephoning, you must observe the legal requirements for the country in which you are currently driving.

Vehicles with the Audio 20 multimedia system: the most recently dialled telephone numbers are displayed on the [Telephone](#) menu.

- ▶ **Select an entry:** swipe upwards or downwards on the left-hand touch control.
- ▶ Press the left-hand touch control.
If there is only one telephone number saved to an entry: the telephone number is selected.
- ▶ **If there are multiple telephone numbers saved to an entry:** swipe upwards or downwards on the left-hand touch control to select the desired telephone number.



- ▶ Press the left-hand touch control.
The telephone number is dialled.



The following displays may appear instead of the telephone numbers dialled:

- **Please wait...:** the application is starting. When a Bluetooth® connection to the mobile phone is not established, the menu for authorising and connecting a mobile phone is displayed in the multimedia system (→ page 279).
- **Updating data...:** the call list is being updated.
- **Importing contacts...:** the contacts from the mobile phone or from a storage medium are being imported.

Accepting/rejecting a call

When you receive a call, the [Incoming call](#) message appears on the head-up display.

- ▶ Swipe upwards or downwards on the left-hand touch control and select  (Accept) or  (Reject).
- ▶ Press the left-hand touch control.

The call may be accepted/rejected using the  or  buttons on the steering wheel.

Adjusting the head-up display settings via the on-board computer

On-board computer:

↳ HUD

The following head-up display settings can be adjusted:

- [Position](#)
- [Brightness](#)
- [Display content](#)

- ▶ **To select a setting:** swipe upwards or downwards on the left-hand touch control.
- ▶ Press the left-hand touch control.
- ▶ **To adjust a value:** swipe upwards or downwards on the left-hand touch control.
- ▶ Press the left-hand touch control.



- ① Setting currently selected
- ② Digital speedometer
- ③ Traffic Sign Assist
- ④ Navigation displays

Setting the design

On-board computer

➔ Design

ⓘ This function is only available for vehicles with a widescreen cockpit.

The following designs can be selected:

- Sport
- Classic
- Progressive

▶ **To select a design:** swipe upwards or downwards on the left-hand Touch Control.

▶ Press the left-hand Touch Control. The instrument display is shown in the selected design.

Head-up Display

Function of the head-up display

Mercedes-AMG vehicles: be sure to observe the notes in the Supplement. Otherwise, you may fail to recognise dangers.

The head-up display projects into the driver's field of vision:

- Information from the navigation system
- Information from the driver assistance systems
- Some warning messages

Display elements

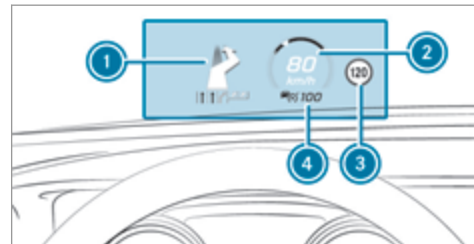

- ① Navigation messages
- ② Current speed
- ③ Detected instructions and traffic signs
- ④ Set speed in the driver assistance system (e.g. cruise control)

When you receive a call, the  Incoming call message appears on the head-up display.

In audio mode, the station name or track is temporarily shown when the active audio source is being operated.

System limits



The visibility is influenced by the following conditions:

- seat position
- the positioning of the display image
- light conditions
- wet road surfaces
- objects on the display cover
- polarisation in sunglasses

 In extreme sunlight, sections of the display may appear washed out. You can correct this by switching the head-up display off and on again.

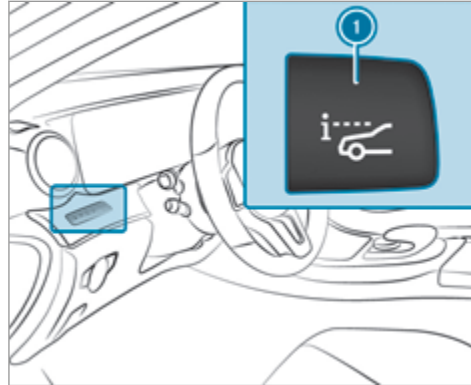
Switching the head-up display on/off



 Press button .

Overview and operation

Overview of the multimedia system

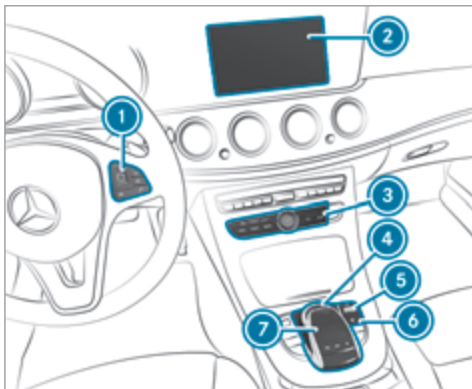

- ① Touch Control
- ② Display
- ③ Main function button group (→ page 268)
- ④ Controller

- ⑤ Control knob, adjusts the volume and switches the sound on or off
- ⑥  button, switches the multimedia system on or off
- ⑦ Touchpad

Notes on the display

NOTE Scratching of the display

The display has a highly sensitive, high-gloss surface. There is a risk of it becoming scratched.

Avoid touching the display.

Observe the notes on cleaning.

Observe the notes on caring for the interior (→ page 319).

Automatic temperature-controlled switch-off feature: if the temperature is too high, the brightness is initially reduced automatically. The display may then switch off completely for a while.

- ⓘ If you are wearing polarised sunglasses, it may be difficult to read the display.

Central control elements overview

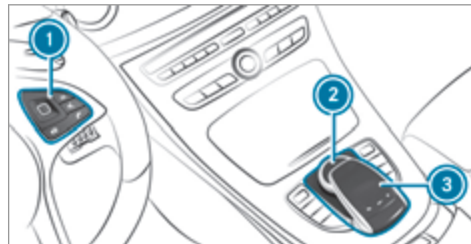

- ① Touch Control
- ② Controller
- ③ Touchpad

The list shows operating options and provides operating examples.

Controller

- **slide**  left or right
 - selects a radio station

- calls up a list
- **slide** ↑↻↓ up or down
 - highlights a preset in the station
 - selects a system language
- **slide** ↘↻↙ diagonally
 - moves the crosshair across the map
- **turn** {↻}
- sound: sets the treble, mid-range and bass
- Selecting a favourite
- connects a mobile phone: selects a mobile phone from the list of detected mobile phones
- **press** Ⓜ
 - Storing radio stations
 - confirms a selection or entry

Touch Control and touchpad (single-finger swipe)

- **swipe** left or right
 - selects a radio station
 - calls up a list

- **swipe** up or down
 - highlights a preset in the station
 - selects a system language
- **swipe** diagonally
 - moves the crosshair across the map
- **press**
 - Storing radio stations
 - confirms a selection or entry

Touchpad (two-finger swipe)

- **turn** right or left using two fingers
 - tone settings: adjusts the treble, mid-range and bass
- move two fingers **apart** or **together**
 - changes the map scale (zoom in or out)

Touch Control

Operating Touch Control

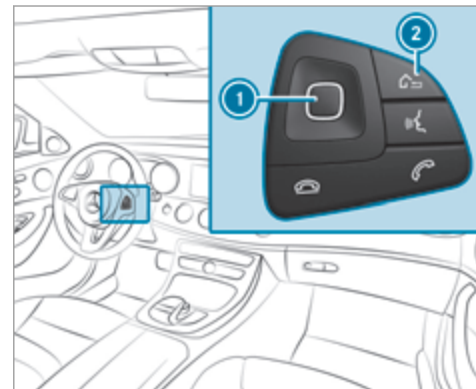

- ▶ **To select a menu item:** swipe up, down, left or right on Touch Control ①.
- ▶ Press Touch Control ①.
- ▶ **To open a list:** press Touch Control ①.
- ▶ **To close a list:** press the ② button.

- ▶ **To move the digital map:** swipe in any direction.

Setting the sensitivity for Touch Control



Multimedia system

↳ [Vehicle](#) ▶ [System settings](#)



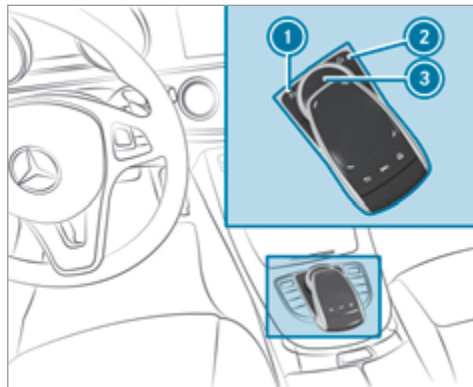

- ▶ Select [Touch Control sensitivity](#).
- ▶ Set the sensitivity.

Operating the controller



- ①  button
Press briefly: returns to the previous display
Press and hold: calls up the basic menu
- ② Button 
Calling up favourites
- ③ Controller

Controller operating options:

- ▶ Turn  left or right.
- ▶ Slide  left or right.
- ▶ Slide  up or down.
- ▶ Slide  diagonally.
- ▶ Press  briefly or press and hold.

Using the controller, you can:

- navigate through menus and lists
- save stations or contacts
- create favourites
- adjust tone settings
- enter characters.

Touchpad

Switching the touchpad on/off

Multimedia system:

↳ [Vehicle](#) ▶ [System settings](#)

- ▶ **Touchpad without handwriting recognition:** switch [Activate touchpad](#) on or off .

- ▶ **Touchpad with handwriting recognition:** select **Touchpad**.



- ▶ Switch **Activate touchpad** on or off .

Operating the touchpad

Requirement:

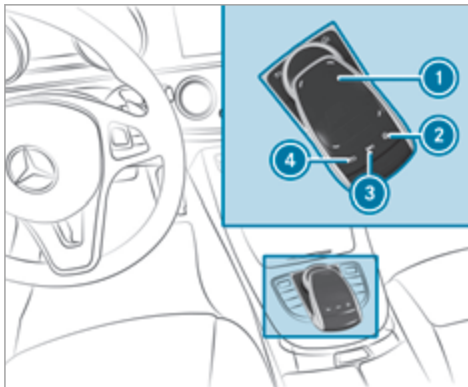
The touchpad is switched on (→ page 266).



- ① Touchpad
- ②  button
Calling up favourites
- ③ Button 
Calls up the control menu of the last active audio source
- ④ Button 

Press briefly: returns to the previous display
Press and hold: calls up the basic menu

You can navigate in menus and lists via touch-sensitive surface ① by using a **single-finger swipe**.

- ▶ **To select the menu item:** swipe up, down, left or right.
- ▶ Press the touchpad.
- ▶ **To close and open lists:** swipe left or right.
- ▶ **To move the digital map:** swipe in any direction.

Use the following functions with a two-finger swipe:

- ▶ **To show or hide the control menu:** swipe up or down with two fingers.
- ▶ **To zoom in and out of the map:** move two fingers apart or together.
- ▶ **To increase or reduce the vehicle settings and tone settings:** turn two fingers clockwise or anti-clockwise.

Handwriting recognition: switching the read-aloud function on/off

Requirement:

The touchpad is equipped with handwriting recognition.

Multimedia system:

↳ [Vehicle](#) ▶ [System settings](#) ▶ [Touchpad](#)

- ▶ Switch [Read out handwriting recognition](#) on or off .

Handwriting recognition: selecting an input language

- ▶ Select .
- ▶ Select an input language.

Selecting a station and track using the touchpad

- ▶ Swipe upwards using two fingers on the touchpad.
A control menu shows the current audio source.
- ▶ Swipe left or right using one finger.
Radio: the previous or next station is set.



Media source: the previous or next track is selected.

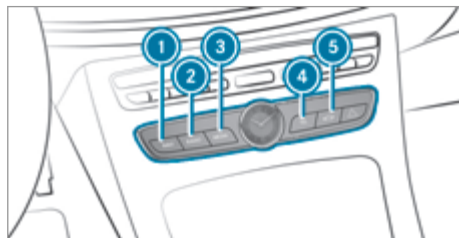

- ▶ **To hide the control menu:** swipe down on the touchpad using two fingers.

Main functions

Calling up the main functions



- ①  button
To call up navigation
- ②  button
To call up the radio
- ③  button
To call up media

- ④  button
To call up the telephone
- ⑤  button
To set vehicle functions

- ▶ Alternative: when the basic menu of a main function is shown, press the  button.

- ▶ **To select a main function:** turn and press the controller.

or

- ▶ Swipe left or right on the touchpad and then press the touchpad.

Calling up menus on the multimedia system

Calling up a menu

- ▶ Call up a main function (→ page 268).
- ▶ **To show the menu:** swipe up or down on the touchpad.

or

- ▶ Slide the controller up or down.
The marker is shown either in the main function line or menu bar.

- ▶ **To select a menu item:** swipe left or right on the touchpad and then press it.

or

- ▶ Slide the controller to the left or right and press it.
Main function line (top) is selected: another main function is called up.
Menu bar (bottom) is selected: a menu appears.

Calling up an operating mode for a main function

- ▶ Call up a main function (→ page 268).
- ▶ Select the main function in the main function line again.
- ▶ Swipe left or right on the touchpad and press it.

or

- ▶ Slide the controller to the left or right and press it.
Depending on the main function, a range of operating modes are available.

For media selection, the following media sources can be selected, for example:

- Memory card
 - Media Interface 1
 - Media Interface 2
 - Bluetooth audio
 - Information on media
- ▶ Alternatively for media selection: select **Devices** in the lower menu bar.
 - ▶ Swipe up or down on the touchpad and press it.

or

- ▶ Slide the controller up or down and press it.
The media source is selected. Playback starts.

Favourites

Overview of favourites

Favourites offer you quick access to frequently used applications. It is possible to create 20 favourites in total.

The following functions are available:

- add **pre-defined favourites** from the following categories:
 - Navigation
 - Entertainment
 - Tel/☎
 - Vehicle
 - Climate control
- add **your own favourites**
- rename a favourite
- move a favourite
- delete a favourite

Calling up favourites

- ▶ Press the  button.
The favourites are displayed.
- ▶ Swipe left or right on the touchpad and press it.

or

- ▶ Turn and press the controller.

Leaving the favourites menu

- ▶ Press the  button again.

Adding a favourite

Adding a pre-defined favourite

- ▶ Press the  button. The favourites are displayed.
- ▶ Swipe down on the touchpad or slide the controller down. The Favourites menu appears.
- ▶ Select [Reassign](#). The categories are displayed.
- ▶ Select a category. The favourites are displayed.
- ▶ Select a favourite.
- ▶ Add a favourite at the desired position. If a favourite has already been added at this position, it will be overwritten.

Example: adding your own favourite

- ▶ Select [Vehicle](#).
- ▶ Select [Full screen: 'Consumption'](#).

- ▶ Press and hold the  button until the favourites are displayed.
- ▶ Add a favourite at the desired position.

Renaming a favourite

- ▶ Press the  button. The favourites are displayed.
- ▶ Select a favourite.
- ▶ Swipe down on the touchpad or slide the controller down. The Favourites menu appears.
- ▶ Select [Rename](#).
- ▶ Enter characters.
- ▶ Confirm the entry.

Moving a favourite

- ▶ Press the  button. The favourites are displayed.
- ▶ Select a favourite.
- ▶ Swipe down on the touchpad or slide the controller down. The Favourites menu appears.
- ▶ Select [Move](#).

- ▶ **To create a favourite at a desired position:** swipe left or right on the touchpad and press it.

or

- ▶ Turn and press the controller. If a favourite has already been added at this position, it will be overwritten.

Deleting a favourite

- ▶ Press the  button. The favourites are displayed.
- ▶ Select a favourite.
- ▶ Navigate downwards once. The Favourites menu appears.
- ▶ Select [Delete](#).
- ▶ Select [Yes](#).

Switching the sound on/off

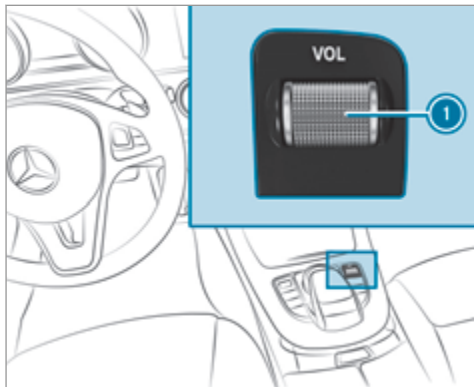

- ▶ **To mute:** press volume control ①.
The  symbol appears in the status line.
You will also hear traffic announcements and navigation announcements even when the sound is muted.
- ▶ **To switch on:** change the media source or adjust the volume.

Adjusting the volume

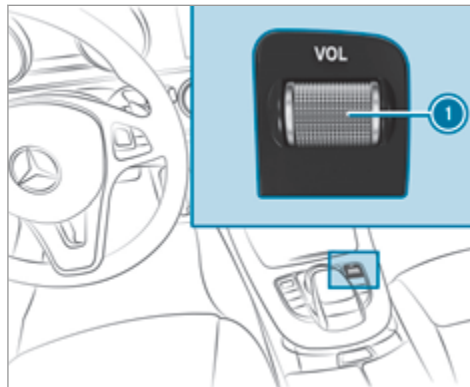

- ▶ Turn volume control ①.
The volume of the current radio or media source is set. You can set the volume of other sound sources separately.
Adjust this in the following situations:
 - during a traffic announcement
 - during a navigation announcement

The volume of the navigation announcement changes in accordance with the volume of the current media source.

- during a telephone call
- ▶ **Alternatively:** select [System](#).
 - ▶ Select [Audio](#).
 - ▶ Select volume settings.
 - ▶ Set the volume.

Entering characters

Using the character input function

On Touch Control

- ▶ Select a character in the character bar.
Depending on the target entry, either a full set of characters is available or, alternatively, only those characters that are available on the basis of the characters that have already been entered.

On the controller

- ▶ Select a character in the character bar. Depending on the target entry, either a full set of characters is available or, alternatively, only those characters that are available on the basis of the characters that have already been entered.

On the touchpad

- ▶ Write the characters on the touch-sensitive surface of the touchpad. Handwriting recognition supports you by means of character suggestions and a read-aloud function.

Switching between central control elements

- ▶ **To activate Touch Control:** press Touch Control.
- ▶ **To activate the controller:** press the controller.
- ▶ **To activate the touchpad:** press the touchpad.

Examples of character entry:

- using a keyword search for a track or artist







- connecting the mobile phone to the multimedia system by entering the passkey
- entering a phone number
- entering a web address

Entering characters using the controller

Entering characters

- ▶ Turn , slide  or  and press the controller.



Use the following editing functions:

-  or 
Switches to upper-case or lower-case letters
- 
Switches to special characters and symbols.
- 
Changes the language
- 
Selects the input line
- 
Moves the cursor within the input line
- 

Deletes a character or an entry

- 
Cancels character entry

Deleting a character or an entry

- ▶ **To delete a character:** when  is highlighted, press the controller.
- ▶ **To delete an entry:** when  is highlighted, press and hold the controller until the entry has been deleted.

Confirming an entry

- ▶ Select .

Entering characters on the touchpad

Entering characters



- ▶ Use one finger to write characters on the surface. The character is entered in the input line. If different interpretations are possible, character suggestions are displayed.

Selecting a character suggestion

- ▶ Turn the controller.

- ▶ Press the touchpad.
- ▶ Resume character input.

The following editing functions can be used:

-  To change the language
-  Selects the input line
Moves the cursor within the input line
-  Cancels character entry

Selecting the input line

- ▶ Select .
- ▶ Swipe up or down.

Moving the cursor within the input line

- ▶ Select .
- ▶ Swipe to the left or right.

Deleting characters

- ▶ When an input line is selected, swipe left.

Confirming an entry

- ▶ Press the touchpad.

System settings

Display

Configuring display settings

Multimedia system:

↳ Vehicle ▶▶ System settings ▶▶ Display

Display design

- ▶ Select Day design, Night design or Automatic.

Display brightness

- ▶ Select Brightness.
- ▶ Select a brightness value.

Switching off the display

Multimedia system:

↳ Vehicle

- ▶ Select Display off.
The display is switched off.

Time and date

Setting the time and date automatically

This function is only available in vehicles with GPS reception.

Multimedia system:

↳ Vehicle ▶▶ Time

- ▶ Switch Automatic time settings on or off .

Setting the time zone

Multimedia system:

↳ Vehicle ▶▶ Time ▶▶ Time zone:

A list of countries is displayed.

- ▶ Select a country ●.
Depending on the country, time zones are displayed.
- ▶ Set the time zone.
The time zone set is displayed after Time zone:.

Setting summer time

The Summer Time and Summer Time setting options cannot be selected in all countries.

Multimedia system:

↪ Vehicle ▶▶ Time

Vehicles with GPS

- ▶ Select [Summer Time](#).
- ▶ Select [On](#), [Off](#) or [Automatic](#).
 - [Automatic](#): the automatic changeover to summer time is not available for all time zones.
 - [Off](#): standard time is set.

Vehicles without GPS

- ▶ Switch [Current time: Summer Time](#) on or off .
- ▶ Summer time changeover: select [Summer Time setting](#).
- ▶ Select [Automatic](#), [Summer Time](#) or [Standard time](#).
The current setting is marked with ●.
The local time is set one hour forward or back.
 - [Automatic](#): the automatic changeover to summer time is not available for all time zones.

Setting the time and date format

Multimedia system:

↪ Vehicle ▶▶ Time ▶▶ Format

- ▶ Set the date and time format ●.

Setting the time and date manually

Multimedia system:

↪ Vehicle ▶▶ Time

Vehicles with GPS

It may be useful to set the time manually in the following situations:

- a country is not contained in the list of time zones
 - a time differing from the local time is set
- ▶ Select [Set time manually](#).
 - ▶ Set the hours.
 - ▶ Navigate to the right to set the minutes.
 - ▶ Set the minutes.
The [Automatic time settings](#) function is deactivated .
- i** The time can be set back by 12 hours and forward by 14 hours.

Vehicles without GPS

- ▶ Select [Set time](#) or [Set date](#).
- ▶ Set the time or date.

The various time and date settings must be set correctly to enable a reliable Internet connection to be established.

Bluetooth®

Information about Bluetooth®

Bluetooth® technology is a standard for short-range wireless data transfer up to approximately 10 m. You can use Bluetooth® to connect your mobile phone to the multimedia system and use the following functions, for example:

- hands-free system with access to the following options:
 - phone book (→ page 283)
 - call lists (→ page 285)
 - messages (→ page 286)
- Internet connection



- listening to music via Bluetooth® audio (→ page 299)
- transferring business cards (vCards) into the vehicle

Bluetooth® is a registered trademark of Bluetooth Special Interest Group (SIG) Inc.

-  Internet connection via Bluetooth® is not available in all countries.

Activating/deactivating Bluetooth®

Multimedia system:

 [Vehicle](#)  [System settings](#)  [Activate Bluetooth](#)

-  Activate or deactivate Bluetooth®.

System language

Setting the system language

Multimedia system:

 [Vehicle](#)  [System settings](#)  [Language](#)



-  Set a language.

Setting the distance unit and temperature unit



Multimedia system:

 [Vehicle](#)  [System settings](#)  [Units](#)

Distance

-  Select [Units](#).
-  Select [km](#) or [mi](#).
-  Switch [Additional speedometer](#) on to display in the instrument cluster's multifunction display.

Temperature

-  Select [Temperature gauge](#).
-  Select [Outside](#) or [Cooling](#).

Data import and export

Importing/exporting data

NOTE Data loss



-  Do not remove the data storage medium when data is being exported.

Mercedes-Benz is not liable for any loss of data.

Requirements:

- The vehicle is stationary.
- The ignition is switched on or the vehicle has been started.
- The SD card is inserted (→ page 296).

Multimedia system

 [Vehicle](#)  [System settings](#)  [Import/export data](#)

-  Select [Import data](#) or [Export data](#).

Importing

-  Select a data storage medium. A prompt appears asking whether you really wish to overwrite the current data.

The existing data in the multimedia system is overwritten, e.g. address data. A message appears.

The multimedia system is restarted once the data has been imported.

Exporting

If PIN protection is activated, the PIN is requested.

- ▶ Enter the four-digit PIN.
- ▶ Select a data storage medium.
The data is exported. The data export may take several minutes.

Activating/deactivating PIN protection for data export

Multimedia system:

↳ [Vehicle](#) ▶ [System settings](#) ▶ [Import/export data](#)

- ▶ **To activate:** activate [Activate PIN protection](#) .
- ▶ Enter your four-digit PIN.
- ▶ Enter your four-digit PIN again.
PIN protection is activated when both PINs match.
- ▶ **To deactivate:** deactivate [Activate PIN protection](#) .
- ▶ Enter your four-digit PIN.

- ⓘ If you have forgotten your PIN, a Mercedes-Benz service centre can deactivate your PIN protection for you.
Alternatively: you can deactivate PIN protection by resetting your personal data (→ page 276).

Reset function

Multimedia system:

↳ [Vehicle](#) ▶ [System settings](#) ▶ [Reset](#)

The multimedia system is reset to the factory settings.

Personal data is deleted, for example:

- station presets
 - connected mobile phones
- ▶ Select [Yes](#).
A query appears asking if you are sure that you want to reset.
[No](#) selected: the process is cancelled.
 - ▶ Select [Yes](#).
The multimedia system is reset to factory settings and restarted.

Garmin® MAP PILOT navigation module

Overview of Garmin® MAP PILOT navigation module

⚠ DANGER Risk of fatal injury from swallowing SD cards

SD cards are small parts.

They could be swallowed and lead to choking.

- ▶ Keep SD cards out of the reach of children.
- ▶ Seek medical attention immediately if an SD card has been swallowed.

⚠ WARNING Risk of distraction from information systems and communications equipment

If you operate information and communication equipment integrated in the vehicle when driving, you will be distracted from the traffic situation. This could also cause you to lose control of the vehicle.

- ▶ Only operate this equipment when the traffic situation permits.
- ▶ If you cannot be sure of this, stop the vehicle whilst paying attention to road and traffic conditions and operate the equipment with the vehicle stationary.

During operation of the Garmin® MAP PILOT, always observe the following:

- the legal requirements for the country in which you are currently driving
- road and traffic rules and regulations always have priority over Garmin® MAP PILOT driving recommendations

Observe the following notes on the operating instructions and updates:

- the Garmin® MAP PILOT operating instructions are stored on the SD memory card as a PDF file.
- the SD card box contains a printed quick guide.

- you can obtain digital map and software updates from a Mercedes-Benz service centre.

For some countries, digital map and software updates are available in the form of a download or an SD memory card.

For downloads, visit <http://shop.mercedes-benz.com> and follow the information in the Garmin® MAP PILOT section.

Further information (see the manufacturer's operating instructions).

Switching the Garmin® MAP PILOT navigation module on

! **NOTE** Damage caused by high temperatures

High temperatures can damage the SD memory card.

- ▶ Remove the SD memory card after use and take it out of the vehicle.

Multimedia system:

➔ Navi



- ▶ Alternatively: press the **NAVI** button.
- ▶ Insert the SD memory card (→ page 296).

Telephone

Telephony

Telephone menu overview



- ① Mobile phone network provider
- ② Signal strength of the mobile phone network
- ③  (telephone ready) or  (call active)

- ④ Bluetooth® device name of the currently connected mobile phone
- ⑤ Telephone menu character bar
- ⑥ To enter characters using the touchpad
- ⑦ To display the phone book

Symbols ① to ④ are not shown until after a mobile phone has been connected to the multimedia system. The symbols depend on your mobile phone and your mobile phone network provider.

The Bluetooth® interface is available to you for telephony. The mobile phone is connected directly via the multimedia system.

If the mobile phone connected supports the MAP Bluetooth® profile (**M**essage **A**ccess **P**rofile), the  menu item is available.

Notes on telephony

⚠ WARNING Risk of distraction from operating integrated communication equipment while the vehicle is in motion

If you operate communication equipment integrated in the vehicle when driving, you will be distracted from the traffic situation. This could also cause you to lose control of the vehicle.

- ▶ Only operate this equipment when the traffic situation permits.
- ▶ If you cannot be sure of this, stop the vehicle whilst paying attention to road and traffic conditions and operate the equipment with the vehicle stationary.

⚠ WARNING Risk of distraction from operating mobile communication equipment while the vehicle is in motion

If you operate communication equipment integrated in the vehicle when driving, you will be distracted from the traffic situation.

This could also cause you to lose control of the vehicle.

Only operate this equipment when the vehicle is stationary.

You must observe the legal requirements for the country in which you are currently driving when operating mobile communication equipment in the vehicle.

Telephony is possible via:

- the Bluetooth® interface

Bluetooth® profile overview

Bluetooth® profile of the mobile phone	Function
PBAP (P hone B ook A ccess P rofile)	Contacts are automatically displayed in the multimedia system
MAP (M essage A ccess P rofile)	Message functions can be used

Further information can be obtained from a Mercedes-Benz service centre or at: <http://www.mercedes-benz.com/connect>.

HD Voice®

- To improve voice quality, the multimedia system supports telephone calls in HD Voice®.
- In order to use this function, the mobile phones and the mobile phone network provider of the person you are calling must support HD Voice®.

Depending on the quality of the connection, the voice quality may fluctuate.

The following situations can lead to the call being disconnected while the vehicle is in motion:

- there is insufficient network coverage in the area
- you move from one GSM or UMTS transmitter/receiver area (cell) into another and no communication channels are free
- the SIM card used is not compatible with the network available

- a mobile phone with "Twincard" is logged into the network with the second SIM card at the same time

Information on telephony

The following situations can lead to the call being disconnected while the vehicle is in motion:

- there is insufficient network coverage in the area
- you move from one GSM or UMTS transmitter/receiver area (cell) into another and no communication channels are free
- the SIM card used is not compatible with the network available
- a mobile phone with "Twincard" is logged into the network with the second SIM card at the same time

HD Voice®

- To improve voice quality, the multimedia system supports telephone calls in HD Voice®.
- In order to use this function, the mobile phones and the mobile phone network pro-

vider of the person you are calling must support HD Voice®.

Depending on the quality of the connection, the voice quality may fluctuate.

Connecting a mobile phone (authorising)

Requirements:

Bluetooth® is activated on the mobile phone (see the manufacturer's operating instructions).

Bluetooth® is activated on the multimedia system (→ page 275).

Multimedia system:

 [Tel/☐](#)  [» Telephone](#) [» Connect device](#)

Searching for a mobile phone

 Select [Search for phones](#).

 Select [Start search](#).

The available mobile phones are displayed. If a new mobile phone is found, it is indicated by the  symbol.

Connecting a mobile phone (authorisation using Secure Simple Pairing)

- ▶ Select a mobile phone.
A code is displayed in the multimedia system and on the mobile phone.
- ▶ **If the codes match:** select **Yes** on the multimedia system.
 - Confirm the code on the mobile phone.
- ▶ **If the codes are different:** select **No** on the multimedia system.
The process is cancelled.

Connecting a mobile phone (authorisation by entering a passkey)

- ▶ Select the Bluetooth® name of the mobile phone.
- ▶ Choose a one to sixteen-digit number combination as a passkey.
- ▶ **Multimedia system:** enter the passkey and select .
- ▶ **Mobile phone:** enter the passkey again and confirm.
- ▶ Depending on the mobile phone used, you may have to confirm the connection to the

multimedia system and for the PBAP and MAP Bluetooth® profiles.

Switching mobile phones

Requirements:

- The mobile phones are authorised (→ page 279).

Multimedia system:

↳ Tel/☉ ▶▶ Telephone ▶▶ Connect device

- ▶ Select the mobile phone from the device list.
- ⓘ Only one mobile phone can be connected at any one time. The mobile phone that is currently connected is indicated with a dot •.

Disconnecting a mobile phone (deauthorising)

Multimedia system:

↳ Tel/☉ ▶▶ Telephone ▶▶ Connect device

- ▶ Highlight the mobile phone in the device list.
- ▶ Select .

- ▶ Select **De-authorise**.
- ▶ Select **Yes**.

Setting the reception and transmission volume

Requirements:

- A mobile phone is connected (authorised) (→ page 279).

Multimedia system:

↳ Tel/☉ ▶▶ Telephone ▶▶ Connect device

This function ensures optimal language quality.

- ▶ Highlight the mobile phone in the device list.
- ▶ Select .
- ▶ Select **Reception volume** or **Transmission volume**.
- ▶ Set the volume.

Further information on the recommended reception and transmission volume: <http://www.mercedes-benz.com/connect>

Universal smartphone cradle

Features of the universal smartphone cradle

- The smartphone cradle is suitable for mobile phones of different sizes.
- An integrated aerial improves mobile phone reception.
- A ventilation system protects the mobile phone from overheating.

Further information can be found at: <http://www.mercedes-benz.com/connect>

Using the universal smartphone cradle

Requirements:

- The mobile phone is connected to the multimedia system for use with the hands-free system (→ page 279).
- The mobile phone must lie flat against the base of the smartphone cradle.
The use of very thick or uneven protective covers may reduce the reception.

- ▶ **To adjust the inclination adjuster:** press the button on the left edge of the smartphone cradle. An inclination adjuster extends from the back of the smartphone cradle and locks in place.

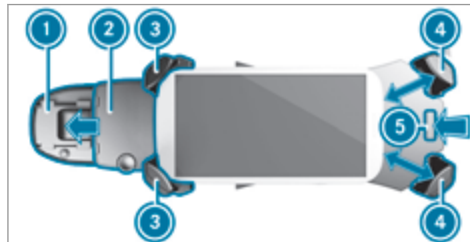

- ▶ **To mount a smartphone cradle:** slide smartphone cradle ② onto contact plate ① in the centre console.
- ▶ **To adjust a smartphone cradle:** press button ⑤. At the same time, move lower brackets ④ into the desired position.
- ▶ **To insert a mobile phone:** connect the cable with the USB port in the stowage compartment in the centre console.

- ▶ Align the mobile phone with upper brackets ③ and slide up to the desired height.
- ▶ Insert the mobile phone. The mobile phone will automatically be held in the smartphone cradle.
- ⓘ Make sure air flow to the mobile phone is not restricted.

Removing the universal smartphone cradle

Requirement:

There is no mobile phone in the smartphone cradle.

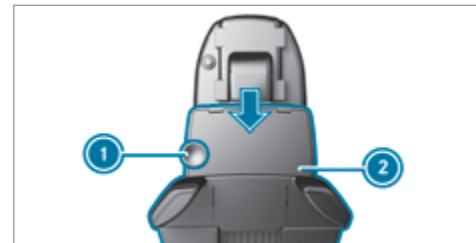

- ▶ Press button ① on the front side of smartphone cradle ②. At the same time, pull the smartphone cradle off the contact plate.

Calls

Telephone operation

Multimedia system:

↳ Tel/🌐 ▶▶ Telephone

Making a call

- ▶ Select the numbers.
- ▶ Select . The call is made.

Accepting a call

- ▶ Select  **Accept**.

Rejecting a call

- ▶ Select  **Reject**.



Ending a call

- ▶ Select .

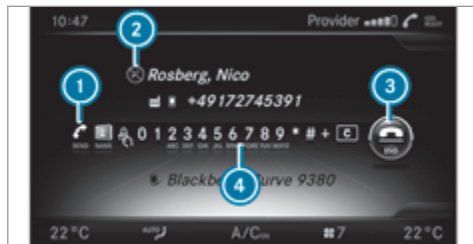
Activating functions during a call



- ① To add a call
- ② Microphone status display
- ③ To end a call
- ④ Character bar

- ▶ **To add a call:** select .
- ▶ Make the call.
- ▶ **To switch the microphone on/off:** navigate downwards. The menu bar is shown.
- ▶ Select **Microphone on** or **Microphone off**.
- ▶ **To end the call:** select .



- ▶ **To send DTMF tones:** enter characters using the character bar.

Conducting calls with several participants

Requirements:

- The mobile phone is connected to the multimedia system (→ page 279).
- At least one call is added (→ page 282).

Switching between calls

- ▶ Select  (1) or  (2). The selected call is active. The other call is on hold.

Activating or ending a call on hold

- ▶ Select  **Continue** or  **End call**.

Conducting a conference call

- ▶ Select **Conference** in the telephone menu. The new participant is included in the conference call.

Ending an active call

- ▶ Select .



- i** On some mobile phones, the call on hold is activated as soon as the active call is ended.

Incoming call during an existing call (call waiting)

Requirements:

- There is an active call (→ page 282).

If you receive a call while already in a call, a message is displayed. An acoustic signal also sounds.

- ▶ Select  **Accept**.
The incoming call is active. The previous call is on hold.
- ▶ Select  **Reject**.

- i** This function and behaviour depends on your mobile phone network provider and the mobile phone (see the manufacturer's operating instructions).

Phone book

Overview of the phone book

The phone book of the mobile phone is automatically displayed in the multimedia system after the connection is established.



- 2,000 entries are reserved for permanently saved contacts in the multimedia system.
- 2,000 entries are reserved for contacts loaded from the mobile phone.

In the telephone book, you can carry out the following actions:

- searching for contacts (→ page 284).
- storing contacts (→ page 284).
- deleting contacts (→ page 285).



Symbol overview

Symbol	Explanation
	Contact stored in the multimedia system.
	Contact called up from a mobile phone.

Symbol	Explanation
	Contact imported from a memory card or a USB device.
	Contact imported via the Bluetooth® interface.

Downloading mobile phone contacts

Multimedia system:

 **Tel/□**  **▶▶ Tele-**
phone ▶▶ Options ▶▶ Call up contacts automatically

Automatically

- ▶ Activate automatic downloading .



Manually

- ▶ Deactivate automatic downloading .
- ▶ Select **Call up contacts**.

Searching for a contact in the phone book

Multimedia system:

 Tel/☎ **»» Telephone** **»» Phone book**

-  Select the characters.
-  Select  .
- The contact is displayed.

Changing the display and the sorting criteria for contacts

Multimedia system:

 Tel/☎ **»» Telephone** **»» Options** **»» Name representation**





The following options are available:

- [Surname, first name](#)
 - [Surname First name](#)
 - [First name Surname](#)
-  Select an option.

Saving a mobile phone contact



Multimedia system:

 Tel/☎ **»» Telephone** **»» Phone book**

-  Searching for a mobile phone contact (→ page 284).
-  Select .
-  Select [Save](#).
- The contact is identified by the  symbol in the phone book.

Importing contacts into the telephone book

Via [Options](#), you can import contacts into the telephone book as electronic business cards using a memory card, USB or Bluetooth®.

Source	Requirements:
 Memory card	The SD memory card is inserted.
 USB device	The USB device is inserted in the USB port.
 Bluetooth® connection	If the sending of vCards is supported via Bluetooth®, vCards can be received on mobile phones or netbooks, for example. Bluetooth® is activated in the multimedia system and on the respective device (see the manufacturer's operating instructions).

Deleting a contact from the phone book

Multimedia system:

↳ Tel/🌐 ➤ Telephone ➤ Phone book

You can delete contacts stored in the vehicle.

- ▶ Switch off automatic download of mobile phone contacts (→ page 283).
- ▶ Highlight a contact in the phone book.
- ▶ Select .
- ▶ Select **Delete contact**.
- ▶ Select **Yes**.

Call lists

Overview of the call lists

If your mobile phone supports the PBAP Bluetooth® profile, the call lists from the mobile phone are displayed in the multimedia system. When connecting the mobile phone, you may have to confirm the connection for the PBAP Bluetooth® profile (see manufacturer's operating manual).

If your mobile phone does not support the PBAP Bluetooth® profile, the multimedia system gener-

ates its own call lists. These are not the same as the call lists in your mobile phone.

If the contact for an incoming call is not yet saved in the multimedia system, you can use the call list to save the telephone number.

Making a call from call lists

Multimedia system:

↳ Tel/🌐 ➤ Telephone ➤ Call lists

- ▶ Select **Incoming calls** or **Calls dialled**.
- ▶ Select an entry.
- ▶ Make the call.

Displaying details from a list entry

Multimedia system:

↳ Tel/🌐 ➤ Telephone ➤ Call lists

- ▶ Select **Incoming calls** or **Calls dialled**. The list is displayed.
- ▶ Highlight an entry.
- ▶ Select .
- ▶ Select **Details**.

Speed dial list

Calling up the speed dial list

Multimedia system:

↳ Tel/🌐 ➤ Telephone ➤ Call lists

- ▶ Select **Speed dial preset list**.

Setting up a speed dial list

Multimedia system:

↳ Tel/🌐 ➤ Telephone ➤ Phone book

- ▶ Select a contact.
- ▶ Select .
- ▶ Select **Assign speed dial preset**.
- ▶ Select the preset for the speed dial.

Deleting speed dial presets

Multimedia system:

↳ Tel/🌐 ➤ Telephone ➤ Call lists ➤ Speed dial preset list

Deleting a speed dial preset

- ▶ Highlight the preset you want to delete.
- ▶ Select .
- ▶ Select **Delete speed dial preset**.

- ▶ Select **Yes**.

Deleting all speed dial presets

- ▶ Highlight a preset.
- ▶ Select .
- ▶ Select **Delete all speed dial presets**.
- ▶ Select **Yes**.

Messages (text messages and e-mails)

Notes on messages

If the connected mobile phone supports the Bluetooth® MAP profile, the message function can be used on the multimedia system. With some mobile phones, some settings still have to be made after connecting to the multimedia system (see the manufacturer's operating instructions).

New messages are identified by the  symbol in the multimedia system display and an audible signal.

The  symbol is displayed when the mobile phone's message memory is full.

Text messages cannot be written while the vehicle is in motion.

You can obtain further information about settings and supported functions of Bluetooth®-capable mobile phones from a Mercedes-Benz service centre or at: <http://www.mercedes-benz.com/connect>

Calling up the settings for messages

Multimedia system:

  **▶▶ Telephone**  **▶▶ Settings**

Configuring an e-mail account

- ▶ Select an e-mail account.
- ▶ The e-mail account is now configured.

Configuring the text messages or e-mails displayed

- ▶ Highlight **Text msg.** or an e-mail account.
- ▶ Select .

A menu with the following options is shown:

- **All messages**
- **New messages**

- **off** (The messages are not displayed automatically.)

- ▶ Select an option.

Reading messages

Multimedia system:

  **▶▶ Telephone** 

In the message menu

Unread messages are displayed.

- ▶ Select a message.

In the message folder

The message menu is displayed.

- ▶ Select  **SMS** or  **E-mail**.
- ▶ Select a message.

Making a call from the messages menu

Multimedia system:

  **▶▶ Telephone** 

Calling a text message sender

- ▶ Highlight a text message.
- ▶ Select .
- ▶ Select **Call sender**.

Calling phone numbers from a message

- ▶ Call up a text message or e-mail.
- ▶ Select a phone number within the message.
- ▶ Select **Call number**.

Mercedes me connect

Information on Mercedes me connect

Mercedes me connect provides the following services:

- breakdown management
- appointment requests or similar
- accident management
- Mercedes-Benz emergency call system

The Mercedes-Benz Customer Centre and the Mercedes-Benz emergency call centre are available for you around the clock.

The Info call button, the breakdown assistance button and the emergency call button can be found on the overhead control panel of the vehicle (→ page 288).

You can also use the multimedia system to make the call (→ page 287).

Please note that Mercedes me connect is a Mercedes-Benz service. In emergencies, always call the national emergency services first using the standard national emergency service phone numbers. In emergencies, you can also use the Mercedes-Benz emergency call system (→ page 290).

Further information on Mercedes me connect, the provided service scope and operation: http://manuals.daimler.com/baix/cars/connectme/de_DE/index.html

Calling the Mercedes-Benz Customer Centre using the multimedia system

Requirements:

In order to be able to use the Mercedes me connect service in the vehicle, the following is required:

- You have access to a GSM network.
- The contract partner's GSM network coverage is available in the respective region.

- The ignition must be switched on so that vehicle data can be transferred automatically.

Multimedia system:

▶ Tel/☉ ▶ Telephone

- ▶ Calling up the phone book (→ page 284).
- ▶ Call **Mercedes me connect**.
After confirmation, the multimedia system sends the required vehicle data.
The data transfer is shown in the display. Then, you can select a service and be connected to a specialist at the Mercedes-Benz Customer Centre.

Further information on Mercedes me connect, the provided service scope and operation is available at: http://manuals.daimler.com/baix/cars/connectme/de_DE/index.html

Making a call via the overhead control panel

Requirements:

In order to be able to use the Mercedes me connect service in the vehicle, the following is required:

- You have access to a GSM network.
- The contract partner's GSM network coverage is available in the respective region.
- The ignition must be switched on so that vehicle data can be transferred automatically.

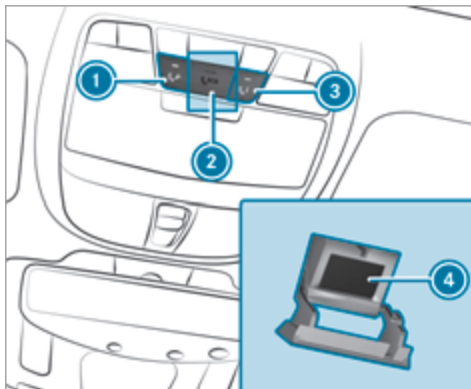

- ① Breakdown assistance call
- ② SOS button cover
- ③ MB Info call
- ④ SOS button

▶ **To make a breakdown assistance call:** press button ①.

▶ **To make an emergency call:** press SOS button cover ② briefly to open.

▶ Press and hold SOS button ④ for at least one second.

▶ **To make an MB Info call:** press button ③.

An emergency call can be initiated even if a breakdown assistance or MB Info call is active. This has priority over all other active calls.

Calls via the overhead control panel are only possible with an available mobile phone network.

More information on Mercedes me connect and further services can be found at: <http://www.mercedes.me>

Information on the MB Info call

An Info call to the Mercedes-Benz Customer Centre has been initiated via the overhead control panel (→ page 288) or the multimedia system (→ page 287).

You can find information on the following topics:

- activation of Mercedes me connect
- Operating the vehicle
- Nearest Mercedes-Benz Service Centre

- Other products and services from Mercedes-Benz

Data is transmitted during the connection to the Mercedes-Benz Customer Centre (→ page 290).

Information on the breakdown assistance call

A breakdown assistance call to the Mercedes-Benz Customer Centre has been initiated via the overhead control panel (→ page 288) or the multimedia system (→ page 287).

- A qualified Mercedes-Benz technician carries out repairs on site and/or the vehicle will be towed to the nearest Mercedes-Benz Service Centre.

You may be charged for these services.

Data is transferred during the connection to the Mercedes-Benz Customer Centre (→ page 290).

Information on Mercedes me connect accident management

The Mercedes me connect accident management is an extension of the Mercedes-Benz emergency call system (→ page 290).

An emergency call is made to the Mercedes-Benz emergency call centre after an accident:

- A voice connection is made to a contact person at the Mercedes-Benz emergency call centre.
- If necessary, the contact person at the Mercedes-Benz emergency call centre forwards the call to Mercedes me connect accident management.
- If necessary, the vehicle will be towed to a Mercedes-Benz service centre.

Arranging a service appointment via Mercedes me connect

If you have activated the maintenance management service, relevant vehicle data is transferred automatically to the Mercedes-Benz Customer Centre. You will then receive individual recommendations regarding the maintenance of your vehicle.

Regardless of whether you have consented to the maintenance management service, the multimedia system reminds you after a certain amount of time that a service is due. A prompt

appears asking if you would like to make an appointment.

▶ **To arrange a service appointment:** select **Call**.

After your confirmation, the vehicle data is sent and a Mercedes-Benz Customer Centre employee deals with your appointment. The information is then sent to your desired service outlet.

This service outlet will then contact you within 24 hours.

ⓘ If you select **Call later** after the service message appears, the message is hidden and reappears after a certain period of time.

Consenting to data transfer for Mercedes me connect

Requirements:

- There is an active breakdown assistance or Info call on the multimedia system (→ page 287) or the overhead control panel (→ page 288).

If the breakdown and Mercedes me connect Concierge services are not activated on

Mercedes me, the [Do you consent to the transfer of vehicle data and vehicle position data to the Mercedes-Benz Customer Centre in order to better deal with your query?](#) message appears.

- ▶ Select **Yes**.
The relevant vehicle data is sent automatically.

More information on Mercedes me: <http://www.mercedes.me>

Transferred data during a service call

In certain countries you must confirm the data transfer.

When you make service calls via Mercedes me connect, the following data is transferred:

Overview of transferred data

Service call	Transferred data
MB Info call Breakdown assistance call	<ul style="list-style-type: none"> • Current vehicle location • Vehicle identification number • Service code • Selected data about the status of the vehicle

Mercedes-Benz emergency call system

Information on the Mercedes-Benz emergency call system

The Mercedes-Benz emergency call system only functions in areas where mobile phone coverage is available from the relevant contract partner. Insufficient network coverage from the relevant contract partner may result in an emergency call not being transmitted.

The ignition must be switched on before an automatic emergency call can be made.

Overview of the Mercedes-Benz emergency call system

The Mercedes-Benz emergency call system can help to decisively reduce the time between an accident and the arrival of emergency services at the site of the accident. It helps locate an accident site in places that are difficult to access.

The emergency call can be made automatically (→ page 291) or manually. Only make emergency calls if you or others are in need of rescue. Do not make an emergency call in the event of a breakdown or a similar situation.

Messages in the multimedia system display:

SOS READY: emergency call available

SOS NOT READY: the ignition is not on or there is a malfunction with the emergency call system.

During an active emergency call,  appears in the display.

You can find more information on the regional availability of the Mercedes-Benz emergency call system at: http://www.mercedes-benz.com/connect_ecall.

- ❗ If an emergency call is unavailable, a message to this effect also appears in the multi-function display of the instrument cluster.

Automatic emergency call

Requirements:

- The ignition is switched on.
- The starter battery has sufficient charge.

If restraint systems such as airbags or seat belt tensioners have been activated after an accident, the Mercedes-Benz emergency call system may automatically initiate an emergency call.

The emergency call has been made:

- A voice connection is made to the Mercedes-Benz emergency call centre.
- A message with accident data is transmitted to the Mercedes-Benz emergency call centre.

The Mercedes-Benz emergency call centre can transmit the vehicle position data to one of the public emergency services call centres.

- In certain situations data is also transmitted in the speech channel to the Mercedes-Benz emergency call centre.

This allows measures for rescue, recovery or towing to a Mercedes-Benz Service Centre to be initiated quickly.

If your vehicle is equipped with an SOS button in the overhead control panel, it flashes until the emergency call has been completed.

It is not possible to immediately end an automatic emergency call.

If the Mercedes-Benz emergency call system cannot connect to the Mercedes-Benz emergency call centre, the emergency call is automatically sent to the public emergency services call centre.

If no connection can be made to the public emergency services, a corresponding message appears in the display.

- ▶ Dial the emergency call number 999 or 112 on your mobile phone.

If an emergency call has been initiated:

- Remain in the vehicle if the road and traffic conditions permit you to do so until a voice connection is established with the emergency call centre operator.
- On the basis of the call, the operator decides whether it is necessary to call rescue teams and/or the police to the accident site.
- If no vehicle occupant answers, an ambulance is sent to the vehicle immediately.

Manual emergency call

- ▶ If the vehicle has an SOS button in the overhead control panel: press and hold the button for at least one second.

The emergency call has been made:

- A voice connection is made to the Mercedes-Benz emergency call centre.
- Remain in the vehicle if the road and traffic conditions permit you to do so until a voice connection is established with the emergency call centre operator.

- On the basis of the call, the operator decides whether it is necessary to call rescue teams and/or the police to the accident site.
- A message with accident data is transmitted to the Mercedes-Benz emergency call centre. The Mercedes-Benz emergency call centre can transmit the vehicle position data to one of the public emergency services call centres.
- In certain situations data is also transmitted in the speech channel to the Mercedes-Benz emergency call centre. This allows measures for rescue, recovery or towing to a Mercedes-Benz Service Centre to be initiated quickly.

If the Mercedes-Benz emergency call system cannot connect to the Mercedes-Benz emergency call centre, the emergency call is automatically sent to the public emergency services call centre.

If no connection can be made to the public emergency services, a corresponding message appears in the display.

- ▶ Dial the emergency number 999 or 112 on your mobile phone.

Ending an unintentional emergency call

- ▶ Select  on the multifunction steering wheel.

Transmitted data with the Mercedes-Benz emergency call system

The following data is transmitted to the Mercedes-Benz emergency call centre:

- the vehicle's GPS position data
- the last GPS position data on the route (a few hundred metres before the incident)
- direction of travel
- vehicle identification number
- the vehicle drive type
- the estimated number of people in the vehicle
- whether Mercedes me connect is available or not
- whether the emergency call was initiated manually or automatically

- the time of the accident
- the language setting on the multimedia system

For accident clarification purposes, the following measures can be taken up to an hour after the emergency call has been initiated:

- the current vehicle position can be called up
 - a voice connection to the vehicle occupants can be established
-  For Russia: various functions, e.g. receiving traffic information, cannot be used for up to two hours after sending an emergency call.

Online and Internet functions

Internet connection

Internet connection restrictions

⚠ WARNING Risk of distraction from information systems and communications equipment

If you operate information and communication equipment integrated in the vehicle when driving, you will be distracted from the traffic situation. This could also cause you to lose control of the vehicle.

- ▶ Only operate this equipment when the traffic situation permits.
- ▶ If you cannot be sure of this, stop the vehicle whilst paying attention to road and traffic conditions and operate the equipment with the vehicle stationary.

You must observe the legal requirements for the country in which you are currently driving when operating the multimedia system.

Internet access may be restricted or not function if:

- the mobile phone is switched off
- the mobile phone network coverage is insufficient
- the mobile phone is not enabled for Internet access
- the Bluetooth® function is switched off on the multimedia system and the desired telephone is to be connected via Bluetooth®
- the Bluetooth® function is switched off on the mobile phone and the telephone is to be connected via Bluetooth®
- neither the mobile phone network nor the mobile phone allow simultaneous use of a telephone and an Internet connection
- the mobile phone has not been enabled for Internet access via Bluetooth®

The Internet functions can only be used to a limited degree whilst driving.

Setting up an Internet connection

Requirements:

- A mobile phone is connected to the multimedia system via Bluetooth® (→ page 279).
To do so, the mobile phone must support one of the following Bluetooth® profiles:
 - DUN (Dial-Up Networking)
 - PAN (Personal Area Network)
- Set the access data of the mobile phone network provider for the connected mobile phone in the multimedia system. If you use incorrect access data, additional costs may be incurred.

You can obtain more detailed information at <http://www.mercedes-benz.com/connect> or from a Mercedes-Benz service centre.

Multimedia system:

 Tel/  Tel/  Internet  Settings  Manage Internet set-

tings ►► Search for Internet devices ►► Start search

- Select the mobile phone.
If the mobile phone supports the Bluetooth® PAN profile, Internet access is set up. You can use the Internet functions. If the mobile phone does not support the named Bluetooth® profile, predefined or manual access data must be set.

Selecting the predefined access data of the mobile phone network provider

- Select **Predefined settings**.
A list of countries appears.
- Select the country of your mobile phone network provider.
The list of available providers appears.
- Select your mobile phone network provider.
An overview of the provider settings appears.
- Select **Confirm settings**.

Manually setting the access data of the mobile phone network provider

- Select **Manual settings**.
An overview of the provider settings appears.
- Set access data.
- Select **Confirm settings**.
- ◻ **i** Set the access data in accordance with your data package. You can contact your mobile phone network provider to obtain the precise access data.

Editing access data

Multimedia system:

►► Tel/□ ►► Tel/□ ►► Internet ►► Settings ►► Manage Internet settings

- Highlight a mobile phone.
- Select .
- Select **Change configuration**.
- Select **Predefined settings** or **Manual settings**.
The provider settings are displayed.
- Set the access data.

Cancelling Internet access permission for a mobile phone

Multimedia system:

►► Tel/□ ►► Tel/□ ►► Internet ►► Settings ►► Manage Internet settings

- Highlight a mobile phone.
- Select .
- Select **Delete configuration**.
- Select **Yes**.

Displaying mobile phone details

Multimedia system:

►► Tel/□ ►► Tel/□ ►► Internet ►► Settings ►► Manage Internet settings

- Highlight a mobile phone.
- Select .
- Select **Details**.

Establishing an Internet connection



Requirements:

- Your connection device is activated and operational.

- Your connection device receives a signal and has a data connection.

Multimedia system:

→ Tel/🌐 → Tel/🌐 → Internet

- ▶ For example, call up the Mercedes-Benz mobile website.
- ▶ **To show the menu:** press the  button.
- ▶ **To end the connection:** select .

Connection status

Connection status overview



- ① Display of existing connection and reception field strength of the mobile phone network

Displaying the connection status

Multimedia system:

→ Tel/🌐 → Tel/🌐 → Internet → Settings

- ▶ Select **Connection status**.

Media

Audio mode

Information on audio mode

⚠ WARNING Risk of distraction when handling data storage media

If you handle a data storage medium while driving, your attention is diverted from the traffic conditions. This could also cause you to lose control of the vehicle.

- ▶ Only handle a data storage medium when the vehicle is stationary.

Permissible file systems:

- FAT32
- exFAT
- NTFS

Permissible data storage medium:

- SD memory card
- USB storage device

- ① The multimedia system supports up to a total of 15,000 files.

Supported formats:

- MP3
- WMA
- AAC formats

- ① Due to the large variety of available music files regarding encoders, sampling rates and data rates, playback cannot always be guaranteed.

- ① Due to the wide range of USB devices available on the market, playback cannot be guaranteed for all brands of USB devices.

- ① Copy-protected music files or DRM encrypted files cannot be played back.

- ① MP3 players must support Media Transfer Protocol (MTP).

Notes on copyright

Audio files that you create or reproduce yourself for playback are generally subject to copyright protection. In many countries, reproductions, even for private use, are not permitted without

the prior consent of the copyright holder. Make sure that you know about the applicable copyright regulations and that you comply with these.

Switching to media mode

Multimedia system:

↪ Media ▶▶ Media

The following functions are available:

- [Memory card](#)
- [Media Interface 1](#)
- [Media Interface 2](#)
- [Bluetooth audio](#)

- ▶ Select the media source.
Playable music files are played back.

Inserting/removing an SD memory card

⚠ DANGER Risk of fatal injury from swallowing SD cards

SD cards are small parts.
They could be swallowed and lead to choking.

- ▶ Keep SD cards out of the reach of children.
- ▶ Seek medical attention immediately if an SD card has been swallowed.

! **NOTE** Damage caused by high temperatures

High temperatures can damage the SD memory card.

- ▶ Remove the SD memory card after use and take it out of the vehicle.

Multimedia system:

↪ Media ▶▶ Media ▶▶ Memory card

Inserting

The multimedia connection unit is located in the stowage compartment under the armrest.

- ▶ Insert the SD memory card into the SD card slot until it engages. The side with the contacts must face downwards.
Playable music files are played back.

Removing

- ▶ Press the SD memory card.
- ▶ Remove the SD memory card.

Overview of the audio mode



- ① Active data storage medium
- ② Playback mode
- ③ Track
- ④ Track number and number of tracks in the track list
- ⑤ Artist and album
- ⑥ Time with elapsed time/time remaining bar
- ⑦ Cover

Connecting USB devices

1 **NOTE** Damage caused by high temperatures

High temperatures can damage USB devices.

- ▶ Remove the USB device after use and take it out of the vehicle.

The multimedia connection unit is found in the storage compartment under the armrest and has two USB ports. Depending on the vehicle's equipment, additional USB ports may be found in the storage compartment of the centre console or rear folding compartment.

- ▶ Connect the USB device to the USB port. Playable music files are played back only if the corresponding media display is activated.

Selecting a track

Multimedia system:

↳ Media ▶▶ Media

- ▶ Select the media source. Playable music files are played back.

Selecting a track using the current track list

- ▶ **To display the current track list:** press the touchpad and controller.
- ▶ Select a track.

Selecting a track by skipping to a track

- ▶ **To skip backwards or forwards to a track:** navigate to the left or right.

Selecting playback options

Multimedia system:

↳ Media ▶▶ Options

Playback mode

- ▶ Select **Play mode**.
- ▶ Select **Normal track sequence**. The current track list is played in the order it appears on the data storage medium.
- ▶ Select **Random track list**. The current track list is played in random order.
- ▶ Select **Random media**. All tracks on the data storage medium are played in random order.

Skip to time

- ▶ Select **Skip to time**.
A menu appears.
- ▶ Set the time.

Showing track information

- ▶ Switch **Show track information** on or off .

Pause and playback function

Multimedia system:

↳ **Media**

Pausing playback

- ▶ Navigate downwards.
- ▶ Select .

Continuing playback

- ▶ Select .

Media search

Starting the media search

Multimedia system:

↳ **Media** ▶ **Search**

Depending on the connected media sources and files, the following categories are listed:

- **Current track list**
- **Folder**
- **Keyword search**
- **Playlists**
- **Artists**
- **Albums**
- **Tracks**
- **Genres**
- **Year**
- **Composers**
- **iTunes U** (Apple® devices)
- **Genius mixes** (Apple® devices)
- **Podcasts** (Apple® devices)
- **Audiobooks** (Apple® devices)

- ▶ Select a category.

Media Interface

Information about the Media Interface

Media Interface is a universal interface for the connection of mobile audio equipment. The multimedia system has two USB ports. The USB ports are located in the stowage compartment under the armrest.

Supported devices

The Media Interface allows you to connect the following data storage media:

- iPod®
- iPhone®
- MP3 player
- USB devices

For details and a list of supported devices, visit our website at <http://www.mercedes-benz.com/connect>. Follow the instructions in the "Media Interface" section.

Switching to Media Interface

Multimedia system:

Media ▶▶ Media ▶▶ Media Interface 1

▶ Connect the data storage medium with the USB port (→ page 297).

Playable music files are played back.

Overview of Media Interface



- ① Active data storage medium
- ② Playback mode
- ③ Track
- ④ Track number and number of tracks in the track list
- ⑤ Artist and album

- ⑥ Time with elapsed time/time remaining bar
- ⑦ Cover

Bluetooth® audio

Information about Bluetooth® audio

Before using your Bluetooth® audio equipment with the multimedia system for the first time, you will need to authorise it (→ page 299).

Bluetooth® Audio overview



- ① Active data storage medium
- ② Playback mode
- ③ Track display

- ④ Connected Bluetooth® audio equipment
- ⑤ Time with elapsed time/time remaining bar
- ⑥ Artist and album

Searching for and authorising a Bluetooth® audio device

Requirements:

Bluetooth® is activated on the multimedia system (→ page 275).

Check your Bluetooth® audio device for the following (see the manufacturer's operating instructions):

- the Bluetooth® audio device must support the A2DP and AVRCP Bluetooth® audio profiles
- the Bluetooth® function must be activated
- the Bluetooth® audio device must be "visible" for other devices
- the Bluetooth® audio device must support Bluetooth® version 2.1 for connection via Secure Simple Pairing.

Multimedia system:

↳ Media ▶▶ Media ▶▶ Bluetooth audio ▶▶ Options ▶▶ Bluetooth audio devices ▶▶ Search for audio devices

- ▶ Select **Start search**.
The multimedia system searches for Bluetooth® audio devices within range and adds them to the Bluetooth® device list.

Option 1: Secure Simple Pairing

- ▶ Select the Bluetooth® audio device. Authorisation starts.
A code is displayed on the multimedia system and on the mobile phone.
- ▶ Confirm on both devices if the codes are identical.

Option 2: entering the passkey

- ▶ Select the Bluetooth® audio device. The input menu for the passkey is displayed.
- ▶ **Multimedia system:** choose a one to sixteen-digit number combination as a passkey.

- ▶ Select OK once all the numbers have been entered.
- ▶ **Mobile phone:** enter the same passkey and confirm your entry.
After successful authorisation, the Bluetooth® audio equipment is connected and starts playing.

Establishing a connection from the Bluetooth® audio equipment

The Bluetooth® device name of the multimedia system is **MB BLUETOOTH**.

- ▶ Select **Connect via audio device**.
- ▶ Start the authorisation on your Bluetooth® audio equipment (see the manufacturer's operating instructions).
After successful authorisation, the Bluetooth® audio equipment is connected and starts playing.

With some Bluetooth® audio equipment, playback must be initially started on the device itself so that the multimedia system can play the audio files.

- ⓘ Device-specific information on authorising and connecting Bluetooth®-capable mobile phones can be obtained at <http://www.mercedes-benz.com/connect> or from a Mercedes-Benz Service Centre.

Activating Bluetooth® audio

Multimedia system:

↳ Media ▶▶ Media

- ▶ Select **Bluetooth audio**.
The multimedia system activates the connected Bluetooth® audio equipment.

Adjusting the volume on the Bluetooth® audio equipment

Multimedia system:

↳ Media ▶▶ Media ▶▶ Bluetooth audio ▶▶ Options ▶▶ Volume

- ▶ Select **Standard** or **Boost**.
- ⓘ On some Bluetooth® audio equipment, the volume can also be adjusted on the device (see the manufacturer's operating instructions).

Displaying Bluetooth® audio equipment details

Multimedia system:

↳ Media ▶▶ Media ▶▶ Bluetooth audio ▶▶ Options ▶▶ Bluetooth audio devices

- ▶ Highlight Bluetooth® audio equipment and navigate to the right.
- ▶ Select **Details**.

Radio

Switching on the radio

Multimedia system:

↳ Radio

- ▶ Alternatively: press the **RADIO** button. The radio display appears. You will hear the last station played on the last frequency band selected.

Radio overview



- ① Memory preset
- ② Display of radio station selected
- ③ Main display field with available stations and relevant information
- ④ Artist and track display

Setting the frequency band

Multimedia system:

↳ Radio ▶▶ Waveband

- ▶ Select the frequency band.

Selecting a radio station

Multimedia system:

↳ Radio

Using the main display field

- ▶ **To select a station:** navigate to the left or right.

Using the current station list

- ▶ Press the touchpad or controller. The station list appears with the stations currently available.
- ▶ Select the station.

Using direct entry

- ▶ Select **Options**.
- ▶ Select **Direct entry**.
- ▶ Select the frequency band.
- ▶ Enter the frequency of the desired station in the entry field.

or



- ▶ Select **Station preset**.

- ▶ Enter the station preset of the desired station.
- ▶ Select  .

Using the preset position

- ▶ Select **Preset**.
- ▶ Select **Enter preset**.
- ▶ Enter the station preset of the desired station.
- ▶ Select  .

Using the search function

- ▶ Select  .
- ▶ Enter the search term.
- ▶ Select  .
The results are displayed.
- ▶ Select the station.

Calling up the radio station list

Multimedia system:

↳ Radio

- ▶ Press the touchpad or controller.
The station list appears.
- ⓘ Each frequency range has its own station list with the stations that can currently be received.

Radio station list with EPG (FM/DAB radio mode)

- ▶ Select **Options**.
- ▶ Select **Current station list with EPG**.
- ▶ Select a station.
- ▶ To switch between **Current programme** and **Programme preview**: navigate to the left or the right.

Sorting the radio station list

Multimedia system:

↳ Radio ▶ Options

- ▶ Select **Sort station list**.
- ▶ Select a sorting option.

Storing radio stations

Multimedia system:

↳ Radio

- ▶ Select **Preset**.
- ▶ Select **Save current station**.
- ▶ Select a location for storing the station.

or

- ▶ In radio mode, press and hold the touchpad or controller until the preset list appears.
- ▶ Select a location for storing the station.

Editing radio station presets

Multimedia system:

↩️ Radio ▶▶ Preset ▶▶ Edit station preset

Deleting stations

- ▶ Highlight a preset entry and navigate to the right.
- ▶ Select [Delete highlighted station/channel](#).
- ▶ Select [Yes](#).

Moving stations

- ▶ Highlight a preset entry and navigate to the right.
- ▶ Select [Move highlighted station/channel](#).
- ▶ Select a location for storing the station.

Activating/deactivating the presets view

Multimedia system:

↩️ Radio ▶▶ Preset

- ▶ Select [Station presets view: on](#).
The radio station preset appears.

- ▶ **To switch between stored stations:** navigate to the left or right.

or

- ▶ Select [Station presets view: off](#).
The frequency band of the station currently being played appears.

Setting station tracking

Multimedia system:

↩️ Radio ▶▶ Options ▶▶ Station tracking

The following options are available:

- **Automatic:** the multimedia system switches to alternative frequencies across all frequency bands.
- **Digital:** switches to alternative frequencies in the DAB frequency band.
- **Analogue:** switches to alternative frequencies in the FM frequency band.
- **Fix frequency:** an alternative frequency is not set. The multimedia system maintains the set frequency when reception is poor.

- ▶ Select an option.

- ① The settings are usually stored and taken into account when calling up a preset again.

Switching on the frequency fix function (FM radio mode)

Multimedia system:

↩️ Radio ▶▶ Options

- ▶ Select [Fix frequency](#).
The multimedia system maintains the set frequency when reception is poor.

Tagging music tracks

Multimedia system:

↩️ Radio ▶▶ Options

If radio stations provide the relevant information, this function allows you to transfer information on the music track currently playing to an Apple® device. You can then purchase the audio file from the iTunes Store®.

- ▶ Select [Tag this track](#).
The track information is saved.

Displaying the artist and track

Multimedia system:

↳ Radio ▶▶ Options

- ▶ Select **Display artist and track**.
- ▶ Switch on a function.

Switching traffic announcements on/off

Multimedia system:

↳ Radio ▶▶ Options ▶▶ TA

- ▶ Activate or deactivate the function.
- or
- ▶ Press and hold the  button on the multifunction steering wheel until the **TA** display in the status line lights up or goes out.

Displaying station information

Requirements:

- Radio stations provide the relevant information.

Multimedia system:

↳ Radio



- ▶ Select **Information**.
- ▶ Additional information is displayed.

Returning to the main display

- ▶ Select **Information**.

Sound

Tone settings

Information about the sound system

The sound system has a total output of 100 watts and is equipped with 7 speakers. It is

available for all functions in the radio and media modes.

Calling up the sound menu

Multimedia system:

↳ Media ▶▶ 

The following functions are available:

- **Equaliser**
- **Balance/Fader**

- ▶ Select the sound menu.

Adjusting treble, mid and bass settings

Multimedia system:

↳ Media ▶▶  ▶▶ **Equaliser**

- ▶ Select the rotary menu.
- ▶ Change the settings.
- ▶ **To exit the menu:** press the  button.

Adjusting the balance/fader

Multimedia system:

↳ Media ▶▶  ▶▶ **Balance/Fader**

- ▶ Adjust the balance and fader.
- ▶ **To exit the menu:** press the  button.

Burmester® surround sound system

Information about the Burmester® surround sound system

The Burmester® surround sound system has a total output of 590 watts and is equipped with 13 speakers. It is available for all functions in the radio and media modes.

Calling up the sound menu in the Burmester® surround sound system

Multimedia system:

Media ▶ 

The following functions are available:

- Equaliser
 - Balance/Fader
 - Surround sound
- ▶ Select the sound menu.

Adjusting the treble, mid and bass settings on the Burmester® surround sound system

Multimedia system:

Media ▶  ▶ Equaliser

- ▶ Select the rotary menu.
- ▶ Change the settings.
- ▶ **To exit the menu:** press the  button.

Adjusting the balance/fader in the Burmester® surround sound system

Multimedia system:

Media ▶  ▶ Balance/Fader

- ▶ Adjust the balance and fader.
- ▶ **To exit the menu:** press the  button.

Switching surround sound on/off in the Burmester® surround sound system

Multimedia system:

Media ▶  ▶ Surround sound

- ▶ Switch the function on/off in the left rotary menu.
- ▶ **To exit the menu:** press the  button.

Adjusting the sound optimisation in the Burmester® surround sound system

Multimedia system:

Media ▶  ▶ Surround sound

- ▶ Adjust the focus in the right-hand carousel menu.
- ▶ **To exit the menu:** press the  button.

ASSYST PLUS service interval display

Function of the ASSYST PLUS service interval display

The ASSYST PLUS service interval display in the instrument display provides information on the remaining time or distance before the next service due date.

You can hide this service message using the back button on the left-hand side of the steering wheel.

You can obtain further information concerning the servicing of your vehicle from a qualified specialist workshop, e.g. a Mercedes-Benz Service Centre.

Displaying the service due date

On-board computer:

↩ Service ▶ ASSYST PLUS

The next service due date is displayed.

▶ **To exit the display:** press the back button on the left-hand side of the steering wheel.

Make sure to observe the following further related subject:

- Operating the on-board computer (→ page 253).

Carrying out maintenance work at regular intervals

! **NOTE** Premature wear through failure to observe service due dates

Service work which is not carried out at the right time or incompletely can lead to increased wear and damage to the vehicle.

- ▶ Always observe the prescribed service intervals.
- ▶ Always have the prescribed service work carried out at a qualified specialist workshop.

Special service requirements

The prescribed service interval is based on normal operation of the vehicle. Maintenance work

will need to be performed more often than specified if the vehicle is operated under arduous conditions or increased loads, for example:

- regular city driving with frequent intermediate stops.
- if the vehicle is primarily used for short-distance driving.
- for frequent operation in mountainous terrain or on poor road surfaces.
- if the engine is often left idling for long periods.
- in particularly dusty conditions and/or if air-recirculation mode is frequently used.

In these or similar operating conditions, have the interior filter, engine air cleaner, engine oil, oil filter etc. changed more frequently. The tyres must be checked more frequently if the vehicle is operated under increased loads. Further information can be obtained at a qualified specialist workshop.

Battery disconnection periods

The ASSYST PLUS service interval display can only calculate the service due date when the battery is connected.

- ▶ Note down the service due date displayed on the instrument display before disconnecting the battery (→ page 306).

Engine compartment

Active bonnet (pedestrian protection)

Operation of the active bonnet (pedestrian protection)

In certain accident situations, the risk of injury to pedestrians can be reduced by the actuation of the active bonnet. The rear area of the engine bonnet is raised by approximately 85 mm.

For the drive to the workshop, reset the triggered active bonnet yourself. If the active bonnet has been triggered, pedestrian protection may be limited.

A qualified specialist workshop must re-instate the full functionality of the active bonnet.

The active bonnet is not available in all countries.

Resetting the active bonnet

⚠ WARNING Danger of burns from hot component parts in the engine compartment

Certain component parts in the engine compartment may be very hot, e.g. the engine, the radiator and parts of the exhaust system.

- ▶ Let the engine cool down and only touch the component parts described below:

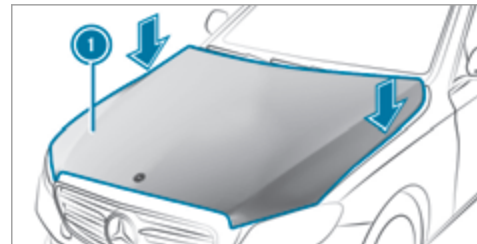

- ▶ With your hand flat, push down active bonnet ① in the area around the hinges on both sides (arrows). The engine bonnet must engage in position.
- ▶ If the active bonnet can be raised slightly at the rear in the area of the hinges, repeat the step until it engages correctly.

Opening/closing the bonnet

⚠ WARNING Risk of accident due to driving with the engine bonnet unlocked

An unlocked engine bonnet may open up when the vehicle is in motion and block your view.

- ▶ Never unlock the engine bonnet when driving.
- ▶ Before every trip, ensure that the engine bonnet is locked.

⚠ WARNING Risk of accident and injury when opening and closing the engine bonnet

When opening or closing the engine bonnet, it may suddenly drop into the end position.

There is a risk of injury for anyone in the engine bonnet's range of movement.

- ▶ Only open or close the engine bonnet when there are no persons in the engine bonnet's range of movement.

⚠ WARNING Danger of burns when opening the bonnet

If you open the engine bonnet when the engine has overheated or during a fire in the engine compartment, you could come into contact with hot gases or other escaping operating fluids.

- ▶ Before opening the bonnet, allow the engine to cool down.
- ▶ In the event of a fire in the engine compartment, keep the engine bonnet closed and call the fire service.

⚠ WARNING Risk of injury due to moving parts

Certain components in the engine compartment may continue to move or suddenly move again even after the ignition has been switched off, e.g. the cooler fan.

Make sure of the following before performing tasks in the engine compartment:

- ▶ Switch the ignition off.

- ▶ Never touch the danger zone surrounding moving component parts, e.g. the rotation area of the fan.
- ▶ Remove jewellery and watches.
- ▶ Keep items of clothing and hair away from moving parts.

⚠ WARNING Risk of injury from touching component parts under voltage

The ignition system and the fuel injection system work under high voltage. If you touch component parts which are under voltage, you could receive an electric shock.

- ▶ Never touch components of the ignition system or the fuel injection system when the ignition is switched on.

⚠ WARNING Danger of burns from hot component parts in the engine compartment

Certain component parts in the engine compartment may be very hot, e.g. the engine,

the radiator and parts of the exhaust system.

- ▶ Let the engine cool down and only touch the component parts described below:

⚠ WARNING Risk of injury from using the windscreen wipers while the engine bonnet is open

When the engine bonnet is open, and the windscreen wipers are set in motion, you can be trapped by the wiper linkage.

- ▶ Always switch off the windscreen wipers and ignition before opening the engine bonnet.

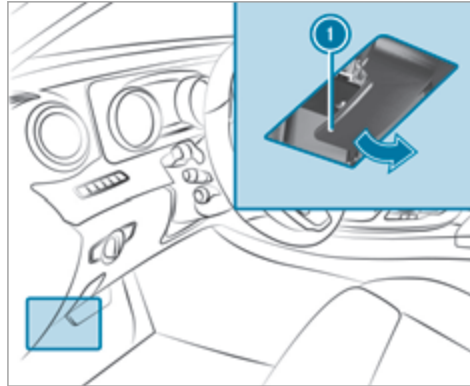

- ▶ **To open:** pull lever ① to release the engine bonnet.

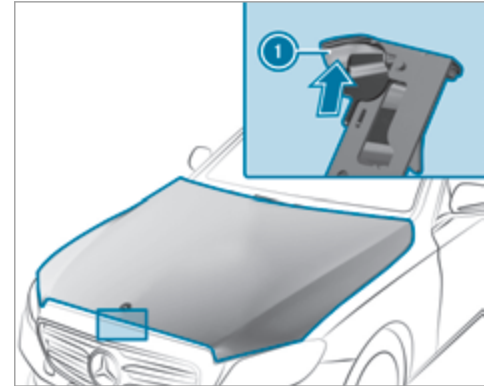

- ▶ Push bonnet catch ① upwards and lift the bonnet by approximately 40 cm.
- ▶ **To close:** lower the bonnet and let it fall from a height of approximately 20 cm.
- ▶ If the bonnet can still be lifted slightly, open the bonnet again and close it with a little more force until it engages correctly.

Engine oil

Checking the engine oil level using the oil dipstick

⚠ WARNING Danger of burns from hot component parts in the engine compartment

Certain component parts in the engine compartment may be very hot, e.g. the engine, the radiator and parts of the exhaust system.

▶ Let the engine cool down and only touch the component parts described below:

Depending on the engine, the oil dipstick may be installed in the engine compartment in different locations.

Waiting time before checking the oil level:

- engine at normal operating temperature: five minutes.

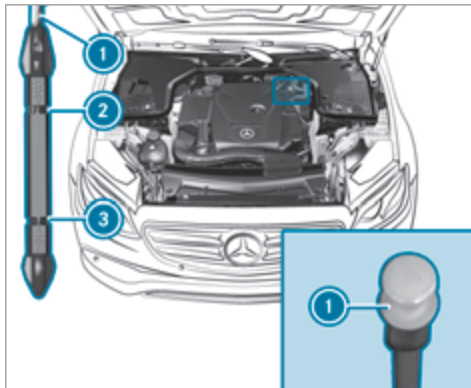

- ▶ Park the vehicle on a flat surface.
- ▶ Remove oil dipstick ① and wipe off.
- ▶ Slowly slide oil dipstick ① into the guide tube to the stop, and take it out again after approximately three seconds.
 - Oil level is correct: oil level is between ② and ③.
 - Oil level too low: oil level is at ③ or below.

- Oil level too high: oil level is above ②.

▶ If the oil level is too low, top up with 1 l of engine oil.

▶ If the oil level is too high, drain off excess engine oil. Consult a qualified specialist workshop.

Checking the engine oil level with an on-board computer

The engine oil level can be checked using the on-board computer for the following models:

- E 200 d, E 220 d, E 220 d 4MATIC
- E 300 d, E 300 de, E 350 d
- E 400 d, E 400 d 4MATIC

The engine oil level is determined during driving. The oil level display is only available after a driving time of up to 30 minutes and if the ignition is switched on, depending on the driving profile.

It is not possible to correctly measure the oil level if:

- the vehicle is not level during the measurement process.
- the bonnet was previously opened.

The engine must be restarted and the engine oil level will be determined again when driving.

On-board computer:

↪ Service ➤ Engine oil level:

You will see one of the following display messages in the multifunction display:

- ▶ **Engine oil level Measuring now:** measurement of the oil level is not yet possible. Repeat the request after a maximum of 30 minutes' driving.
- ▶ **Engine oil level OK** and the bar display for indicating the oil level in the multifunction display is green and is between "min" and "max": the oil level is correct.
- ▶ **Engine oil level Add 1,0 l** and the bar display for indicating the oil level in the multifunction display is orange and is below "min": top up with 1 l of engine oil.
- ▶ **Reduce engine oil level** and the bar display for indicating the oil level in the multifunction display is orange and is above "max": drain off the excess engine oil. Consult a qualified specialist workshop.

- ▶ **For engine oil level turn on ignition:** switch on the ignition to check the engine oil level.
- ▶ **Engine oil level System inoperative:** sensor faulty or not connected. Consult a qualified specialist workshop.
- ▶ **Engine oil level System currently unavail.:** close the bonnet.

Topping up engine oil

⚠ WARNING Danger of burns from hot component parts in the engine compartment

Certain component parts in the engine compartment may be very hot, e.g. the engine, the radiator and parts of the exhaust system.

- ▶ Let the engine cool down and only touch the component parts described below:

⚠ WARNING Risk of fire and injury from engine oil

If engine oil comes into contact with hot component parts in the engine compartment, it may ignite.

- ▶ Make sure that no engine oil is spilled next to the filler opening.
- ▶ Allow the engine to cool off and thoroughly clean the engine oil from component parts before starting the vehicle.

! NOTE Engine damage caused by an incorrect oil filter, incorrect oil or additives

- ▶ Do not use engine oils or oil filters which do not correspond to the specifications explicitly prescribed for the service intervals.
- ▶ Do not alter the engine oil or oil filter in order to achieve longer change intervals than prescribed.
- ▶ Do not use additives.

- ▶ Follow the instructions in the service interval display regarding the oil change.

! **NOTE** Damage caused by topping up too much engine oil

Topping up too much engine oil can cause damage to the engine or the catalytic converter.

- ▶ Have excess engine oil removed at a qualified specialist workshop.

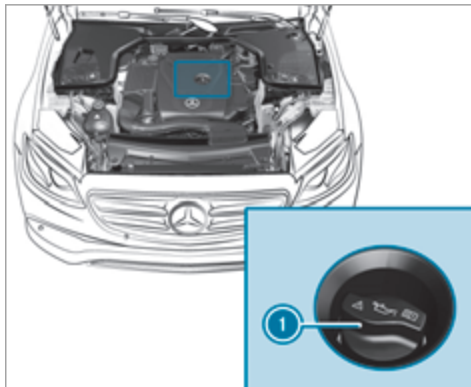

- ▶ Turn cap ① anti-clockwise and remove it.
- ▶ Top up the engine oil.
- ▶ Replace cap ① and turn it clockwise as far as it will go.
- ▶ Check the oil level again (→ page 310).

Checking the coolant level

! **WARNING** Danger of burns from hot component parts in the engine compartment

Certain component parts in the engine compartment may be very hot, e.g. the engine, the radiator and parts of the exhaust system.

- ▶ Let the engine cool down and only touch the component parts described below:

! **WARNING** Danger of burns from hot coolant

The engine cooling system is pressurised, particularly when the engine is warm. If you open the cap, you could be scalded by hot coolant spraying out.

- ▶ Let the motor cool down before opening the cap.
- ▶ When opening the cap, wear gloves and protective eyewear.

- ▶ Slowly turn the cap half a turn to allow pressure to escape.

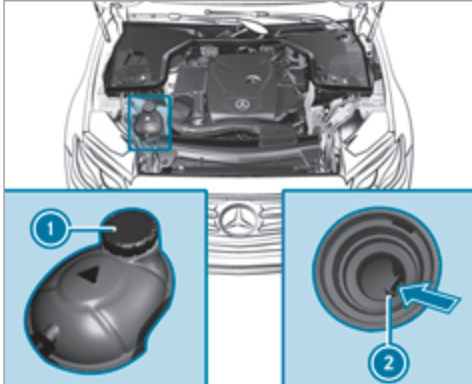

- ▶ Park the vehicle on a level surface.
- ▶ Check the coolant temperature display in the instrument cluster. The coolant temperature must be below 70 °C.

- ▶ Slowly turn cap ① anti-clockwise to relieve excess pressure.
- ▶ Continue turning cap ① anti-clockwise and remove it.

The coolant level is correct:

- if the engine is cold up to marker bar ②
- if the engine is warm up to 1.5 cm over marker bar ②
- ▶ If necessary, top up with coolant that has been approved by Mercedes-Benz.
 - Further information on coolant (→ page 375)

Topping up the windscreen washer system

- ⚠ **WARNING** Danger of burns from hot component parts in the engine compartment

Certain component parts in the engine compartment may be very hot, e.g. the engine, the radiator and parts of the exhaust system.

- ▶ Let the engine cool down and only touch the component parts described below:

- ⚠ **WARNING** Danger of burns when opening the bonnet

If you open the engine bonnet when the engine has overheated or during a fire in the engine compartment, you could come into contact with hot gases or other escaping operating fluids.

- ▶ Before opening the bonnet, allow the engine to cool down.
- ▶ In the event of a fire in the engine compartment, keep the engine bonnet closed and call the fire service.

- ⚠ **WARNING** - Risk of fire and injury due to windscreen washer concentrate

Windscreen washer concentrate is highly flammable. It could ignite if it comes into contact with hot engine component parts or the exhaust system.

- ▶ Make sure that no windscreen washer concentrate spills out next to the filler opening.

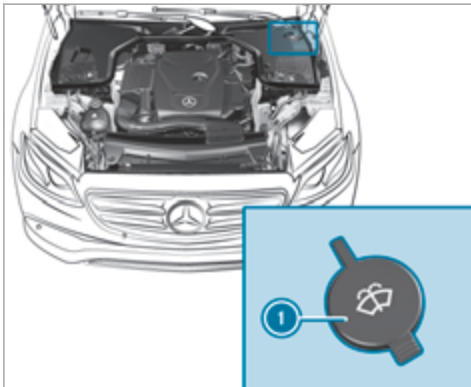

- ▶ Remove cap ① by the tab.
- ▶ Top up the washer fluid.

Cleaning and care

Information on washing the vehicle in a car wash

⚠ WARNING Risk of an accident due to reduced braking power after washing the vehicle

Braking efficiency is reduced after washing the vehicle.

- ▶ After the vehicle has been washed, brake carefully while paying attention to the traffic conditions until braking power has been fully restored.

To avoid damage to your vehicle when using a car wash, ensure the following beforehand:

- Active Distance Assist DISTRONIC and the HOLD function are deactivated.
- The 360° camera or the reversing camera is switched off.
- The side windows and sliding sunroof are completely closed.

- The blower for the ventilation/heating is switched off.
 - The windscreen wiper switch is in position **0**.
 - In car washes with a towing mechanism: neutral **N** is engaged.
 - The key is at a distance of at least 3 m away from the vehicle, otherwise the boot lid could open unintentionally.
- i** If, after the car wash, you remove the wax from the windscreen and wiper rubber, this will prevent smearing and reduce wiper noise.

Information on using a high-pressure cleaner

⚠ WARNING Risk of an accident when using high-pressure cleaners with circular jet nozzles

The water jet of a circular jet nozzle (dirt grinder) can cause externally invisible damage to the tyres or chassis parts.

Components damaged in this way may unexpectedly fail.

- ▶ Do not use high-pressure cleaners with circular jet nozzles to clean the vehicle.
- ▶ Have damaged tyres or chassis parts replaced immediately.

To avoid damage to your vehicle, observe the following when using a high-pressure cleaner:

- Keep the key at least 3 m away from the vehicle. Otherwise the boot lid could open unintentionally.
 - Maintain a distance of at least 30 cm to the vehicle.
- **Vehicles with decorative foil:** parts of your vehicle are covered with a decorative foil. Maintain a distance of at least 70 cm between the foil-covered parts of the vehicle and the nozzle of the high pressure cleaner. Move the high-pressure cleaner nozzle around whilst cleaning.
 - Observe the information on the correct distance in the equipment manufacturer's operating instructions.
 - Do not point the nozzle of the high-pressure cleaner directly at sensitive parts such as tyres, slits, electrical component parts, batteries, light sources and ventilation slots.

Washing the vehicle by hand

Observe the legal requirements, e.g. in a number of countries, washing by hand is only permitted in specially designated wash bays.

- ▶ Use a mild cleaning agent, e.g. car shampoo.
- ▶ Wash the vehicle with lukewarm water using a soft car sponge. When doing so, do not expose the vehicle to direct sunlight.
- ▶ Carefully hose the vehicle off with water and dry using a chamois. Take care not to point the water jet directly towards the air inlet.

Notes on paintwork/matt finish paintwork care

Observe the following information:

	Cleaning and care	Avoiding paintwork damage
Paintwork	<ul style="list-style-type: none"> • Insect remains: soak with insect remover and rinse off the treated areas afterwards. • Bird droppings: soak with water and rinse off afterwards. • Coolant, brake fluid, tree resins, oils, fuel and greases: remove by gently rubbing with a cloth soaked in petroleum ether or lighter fluid. • Tar stains: use tar remover. • Wax: use silicone remover. 	<ul style="list-style-type: none"> • Do not attach stickers, films or similar. • Remove dirt immediately, where possible.
Matt finish	<ul style="list-style-type: none"> • Only use care products approved by Mercedes-Benz. 	<ul style="list-style-type: none"> • Do not polish the vehicle and light-alloy wheels. • Only use car washes that correspond to the latest engineering standards. • Do not use car wash programmes with a final hot wax treatment. • Do not use paint cleaners, buffing or polishing products, gloss preservers, e.g. wax. • Always have paintwork repairs carried out at a qualified specialist workshop.

Notes on care of car parts

⚠ WARNING Risk of entrapment if the windscreen wipers are switched on while the windscreen is being cleaned

If the windscreen wipers are set in motion while you are cleaning the windscreen or wiper blades, you can be trapped by the wiper arm.

▶ Always switch off the windscreen wipers and the ignition before cleaning the windscreen or wiper blades.

⚠ WARNING Risk of burns from tailpipes and tailpipe trim

The tailpipe and tailpipe trim can become very hot. If you come into contact with these parts of the vehicle, you could burn yourself.

▶ Always be particularly careful around the tailpipe and the tailpipe trim.
▶ Allow the vehicle parts to cool down before you touch them.

Observe the following information:

Notes on cleaning and care		Avoiding vehicle damage
Wheels/rims	Use water and acid-free wheel cleaners.	<ul style="list-style-type: none"> • Do not use acidic wheel cleaners to remove brake dust. This could damage wheel bolts and brake components. • To avoid corrosion of the brake discs and brake pads, drive the vehicle for a few minutes after cleaning before parking it. The brake discs and brake pads warm up and dry out.
Windows	Clean the windows on the inside and outside using a damp cloth and cleaning agents recommended by Mercedes-Benz.	Do not use dry cloths or abrasive or solvent-based cleaning agents to clean the inside of windows.

	Notes on cleaning and care	Avoiding vehicle damage
Wiper blades	Fold out the wiper blades and clean them using a damp cloth.	Do not clean the wiper blades too often.
Exterior lighting	Clean the lenses with a wet sponge and mild cleaning agent, e.g. car shampoo.	Only use cleaning agents or cleaning cloths that are suitable for plastic lenses.
AIRPANEL	<p>If the vehicle is very dusty or there are salt deposits in the AIRPANEL mechanics, the adjustment range of the shutters in the radiator trim may be restricted.</p> <ul style="list-style-type: none"> • Switch on the ignition, and the shutters open automatically after approximately 120 seconds. • Clean the bearing points of the shutters with a high-pressure water jet. 	When using a high-pressure cleaner, maintain a minimum distance of 30 cm.
Sensors	Clean the sensors in the front and rear bumper and in the radiator trim with a soft cloth and car shampoo.	When using a high-pressure cleaner, maintain a minimum distance of 30 cm.
Reversing camera and 360° Camera	<ul style="list-style-type: none"> • Open the camera cover with the multimedia system(→ page 223) . • Use clear water and a soft cloth to clean the camera lens. 	Do not use a high-pressure cleaner.

Notes on cleaning and care		Avoiding vehicle damage
Exhaust pipes	Clean with cleaning agents recommended by Mercedes-Benz, particularly in the winter and after washing the vehicle.	Do not use acidic cleaning agents.
Trailer tow hitch	<ul style="list-style-type: none"> • Remove traces of rust on the ball, e.g. with a wire brush. • Remove dirt with a lint-free cloth. • After cleaning, oil or grease the ball coupling lightly. • Observe the notes on care in the trailer tow hitch manufacturer's operating instructions. 	Do not clean the ball coupling with a high-pressure cleaner or solvent.

Notes on care of the interior

⚠ WARNING Risk of injury from plastic parts breaking off after the use of solvent-based care products

Care and cleaning products containing solvents can cause surfaces in the cockpit to become porous.

When the airbags are deployed, plastic parts may break away.

▶ Do not use any care or cleaning products containing solvents to clean the cockpit.

⚠ WARNING Risk of injury or death from bleached seat belts

Bleaching or dyeing seat belts can severely weaken them.

This can, for example, cause seat belts to tear or fail in an accident.

▶ Never bleach or dye seat belts.

Observe the following information:

Information on cleaning and care		Avoiding vehicle damage
Seat belts	Clean with warm water and soap solution.	<ul style="list-style-type: none"> Do not use chemical cleaning agents. Do not dry seat belts by heating them to over 80 °C or exposing them to direct sunlight.
Display	Clean the surface carefully with a microfibre cloth and TFT/LCD display cleaner.	<ul style="list-style-type: none"> Switch off the display and allow to cool. Do not use any other cleaning products.
Plastic trim	<ul style="list-style-type: none"> Clean with a damp microfibre cloth. If the trim is very dirty: use a cleaning agent recommended by Mercedes-Benz. 	<ul style="list-style-type: none"> Do not apply stickers, films etc. Do not allow cosmetics, insect repellent or sun cream to come in contact with the plastic trim.
Genuine wood/trim elements	<ul style="list-style-type: none"> Clean with a microfibre cloth. Black piano-lacquer look: clean with a damp cloth and soap solution. If the trim is very dirty: use a cleaning agent recommended by Mercedes-Benz. 	Do not use solvent-based cleaning agents, polishes or waxes.
Roof lining	Clean with a brush or dry shampoo.	
Carpet	Use carpet and textile cleaning agents recommended by Mercedes-Benz.	

	Information on cleaning and care	Avoiding vehicle damage
Genuine leather seat covers	<ul style="list-style-type: none"> • Clean with a damp cloth and then wipe with a dry cloth. • Leather care: use leather care agents that have been recommended by Mercedes-Benz. 	<p>Do not allow the leather to become too damp. Do not use a microfibre cloth.</p>
DINAMICA seat covers	Clean with a damp cloth.	Do not use a microfibre cloth.
Artificial leather seat covers	Clean with a damp cloth and 1% soap solution.	Do not use a microfibre cloth.
Cloth seat covers	Clean with a damp cloth and 1% soap solution and allow to dry.	
EASY-PACK boot box	Clean with a damp cloth.	Do not use any alcohol-based thinners, petrol or abrasive cleaning agents.

Emergency

Removing the reflective safety jacket

The reflective safety jackets are located in the safety jacket compartments in the driver's and front-passenger door stowage compartments.

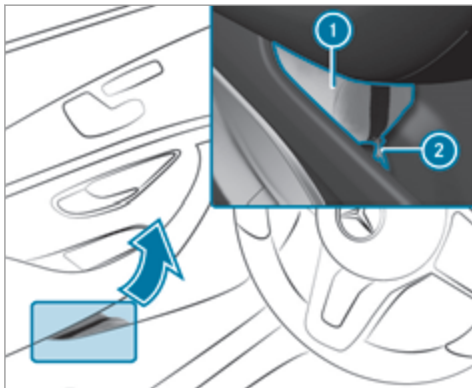

To remove: pull out safety jacket bag ① by loop ②.

▶ Open safety jacket bag ① and pull out the safety jacket.

ⓘ There are also safety jacket compartments in the rear door stowage compartments in which safety jackets can be stowed.

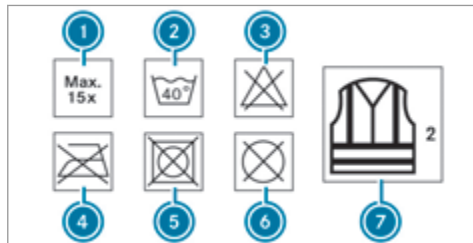

- ① Maximum number of washes
- ② Maximum wash temperature
- ③ Do not bleach
- ④ Do not iron
- ⑤ Do not use a laundry dryer
- ⑥ Do not dry-clean
- ⑦ This is a class 2 jacket

The requirements defined by the legal standard are only fulfilled if the safety jacket is the correct size and is fully closed.

Replace the safety jacket if:

- it is damaged or dirt on the reflective strips can no longer be removed
- the maximum number of washes is exceeded
- the fluorescence of the safety jacket has faded

Warning triangle

Removing the warning triangle

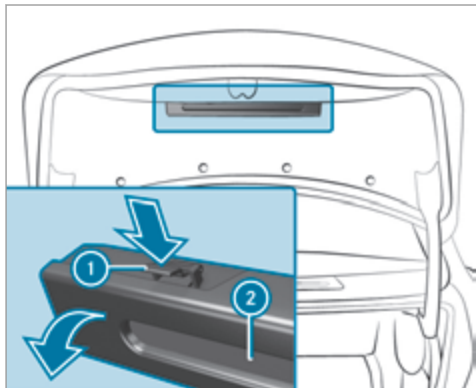

- ▶ Push both sides of warning triangle holder ① in the direction of the arrow and open it.
- ▶ Remove warning triangle ②.

Setting up the warning triangle

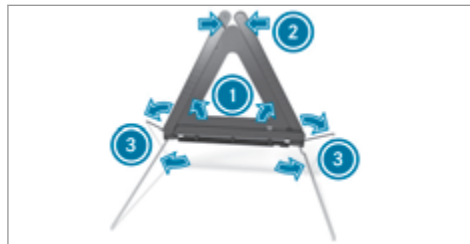

- ▶ Fold side reflectors ① upwards to form a triangle and attach at the top using press-stud ②.
- ▶ Fold legs ③ down and out to the side.

First-aid kit (soft sided)

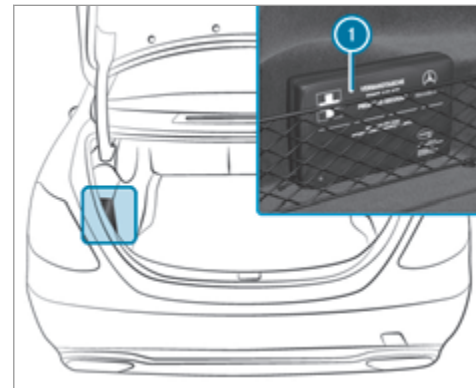

The first-aid kit ① is in the boot in the left-hand storage net.

Removing the fire extinguisher

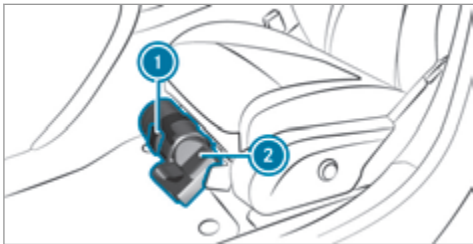

- ▶ **Left-hand-drive vehicle:** Pull tab ① upwards.
- ▶ **Right-hand-drive vehicle:** Pull tab ① downwards.
- ▶ Remove fire extinguisher ②.

Flat tyre

Notes on flat tyres

⚠ WARNING Risk of accident due to a flat tyre

A flat tyre severely affects the driving characteristics as well as the steering and braking of the vehicle.

Tyres without run-flat characteristics:

- ▶ Do not drive on with a flat tyre.
- ▶ Change the flat tyre immediately with the emergency spare wheel or spare wheel. Alternatively, consult a qualified specialist workshop.

Tyres with run-flat characteristics:

- ▶ Observe the information and warning notes on MOExtended tyres (run-flat tyres).

In the event of a flat tyre, the following options are available depending on your vehicle's equipment:

- **Vehicles with MOExtended tyres:** it is possible to continue the journey for a short period of time. Make sure you observe the notes on MOExtended tyres (run-flat tyres) (→ page 325).
 - **Vehicles with a TIREFIT kit:** you can repair the tyre so that it is possible to continue the journey for a short period of time. To do this, use the TIREFIT kit (→ page 326).
 - **Vehicles with Mercedes me connect:** you can make a call for breakdown assistance via the overhead control panel in the case of a breakdown (→ page 288).
 - **All vehicles:** change the wheel (→ page 357).
- ① The emergency spare wheel is only available in certain countries.

MOExtended tyres (run-flat tyres)

⚠ WARNING Risk of accident when driving in limp-home mode

When driving in emergency mode the handling characteristics are impaired. e.g. when cornering, when accelerating strongly and when braking.

- ▶ Do not exceed the specified maximum speed.
- ▶ Avoid any abrupt steering and driving manoeuvres as well as driving over obstacles (kerbs, pot holes, off-road). This applies, in particular, to a loaded vehicle.
- ▶ Stop driving in the emergency mode if you notice:
 - banging noise
 - vehicle vibration
 - smoke which smells like rubber
 - continuous ESP® intervention
 - cracks in tyre side walls

- ▶ After driving in emergency mode have the rims checked by a qualified specialist workshop with regard to their further use.
- ▶ The defective tyre must be replaced in every case.

With MOExtended tyres (run-flat tyres), you can continue to drive your vehicle even if there is a total loss of pressure in one or more tyres. However, the tyre affected must not show any clearly visible damage.

You can recognise MOExtended tyres by the MOExtended marking which appears on the side wall of the tyre.

Vehicles with tyre pressure loss warning system: MOExtended tyres may only be used in conjunction with an activated tyre pressure loss warning system.

Vehicles with tyre pressure monitoring system: MOExtended tyres may only be used in conjunction with an activated tyre pressure monitoring system.

If a pressure loss warning message appears in the multifunction display:

- Check the tyre for damage.
- If driving on, observe the following notes.

Driving distance possible in limp-home mode after the pressure loss warning:

Load condition	Driving distance possible in limp-home mode
Partially laden	80 km
Fully laden	30 km

- The driving distance possible in limp-home mode may vary depending on the driving style.
- Maximum permissible speed 80 km/h.

If a tyre has gone flat and cannot be replaced with an MOExtended tyre, you can use a standard tyre as a temporary measure.

TIREFIT kit storage location

The TIREFIT kit is located under the boot floor.

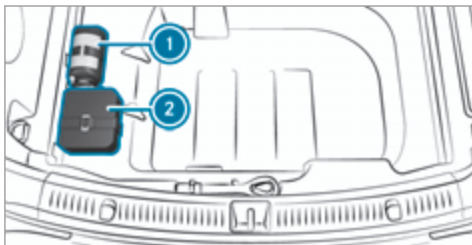

- ① Tyre sealant bottle
- ② Tyre inflation compressor
- ⓘ You can find information on the power category and/or electrical data on the back of the tyre inflation compressor.
 - LK2 – 12 V/15A, 180 W, 0.8 kg

At a distance of approximately 1 m to the tyre inflation compressor and approximately 1.6 m above the ground, the following sound pressure levels apply:

- Emission sound pressure level L_{PA} 83 dB (A)
- Sound power level L_{WA} 91 dB (A)

The tyre inflation compressor is maintenance-free. If there is a malfunction, please contact a qualified specialist workshop.

Using the TIREFIT kit

Requirements:

Have the following tools readily available:

- Tyre sealant bottle
- Sticker TIREFIT
- Tyre inflation compressor

You can use TIREFIT tyre sealant to seal perforation damage of up to 4 mm, particularly those in the tyre tread. You can use TIREFIT in outside temperatures down to -20 °C.

⚠ WARNING Risk of accident when using tyre sealant

In the following situations, the tyre sealant is unable to provide sufficient breakdown assistance, as it is unable to seal the tyre properly:

- there are cuts or punctures in the tyre larger than those previously mentioned.
- the wheel rim is damaged.
- you have driven at very low tyre pressures or on a flat tyre.

▶ Do not drive on.

▶ Consult a qualified specialist workshop.

⚠ WARNING Risk of injury and poisoning from tyre sealant

Tyre sealant is hazardous to health and causes irritation. Do not allow it to come into contact with your skin, eyes or clothing, and do not swallow it. Do not inhale any vapours. Keep the tyre sealant away from children.

Observe the following if you come into contact with the tyre sealant:

- ▶ Rinse off the tyre sealant from your skin using water immediately.
- ▶ If tyre sealant gets into your eyes, thoroughly rinse them using clean water immediately.
- ▶ If tyre sealant has been swallowed, thoroughly rinse out your mouth immediately and drink plenty of water. Do not induce vomiting and seek medical attention immediately.
- ▶ Change out of clothing which has come into contact with tyre sealant immediately.
- ▶ If an allergic reaction occurs, seek medical attention immediately.

! **NOTE** Overheating due to the tyre inflation compressor running too long

- ▶ Do not run the tyre inflation compressor for longer than ten minutes without interruption.

Comply with the manufacturer's safety notes on the sticker on the tyre inflation compressor.

Have the tyre sealant bottle replaced in a qualified specialist workshop every five years.

- ▶ Do not remove any foreign objects which have entered the tyre.

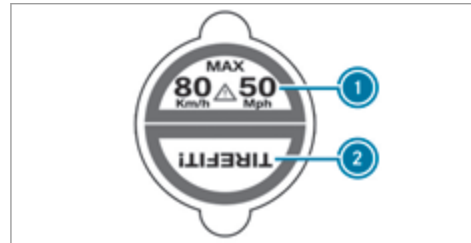

- ▶ Affix part ① of the TIREFIT sticker to the instrument cluster within the driver's field of vision.
- ▶ Affix part ② of the TIREFIT sticker near the valve on the wheel with the defective tyre.

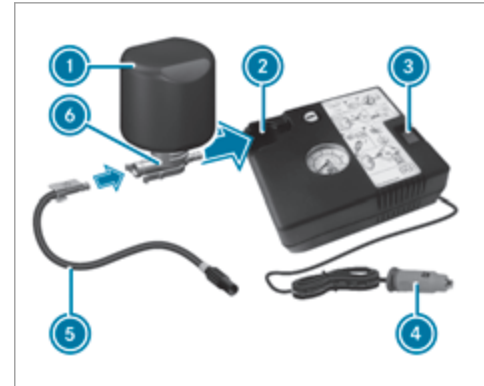

- ▶ Pull plug ④ with the cable and hose ⑤ out of the tyre inflation compressor housing.
- ▶ Push the plug of hose ⑤ into flange ⑥ of tyre sealant bottle ① until the plug engages.
- ▶ Place tyre sealant bottle ① head downwards into recess ② of the tyre inflation compressor.



- ▶ Remove the valve cap from valve ⑦ on the faulty tyre.
- ▶ Screw filler hose ⑧ onto valve ⑦.
- ▶ Insert plug ④ into a 12 V socket in your vehicle.
- ▶ Switch the ignition on.
- ▶ Press on and off switch ③ on the tyre inflation compressor.
The tyre inflation compressor is switched on. The tyre is inflated. First, tyre sealant is pumped into the tyre. The pressure may briefly rise to approximately 500 kPa (5 bar/73 psi).

Do not switch off the tyre inflation compressor during this phase.

- ▶ Let the tyre inflation compressor run for a maximum of ten minutes.
The tyre should then have attained a tyre pressure of at least 200 kPa (2.0 bar/29 psi).

If tyre sealant leaks out, make sure you clean the affected areas as quickly as possible. It is preferable to use clean water.

If you get tyre sealant on your clothing, have it cleaned as soon as possible with perchloroethylene.

If, after ten minutes, a tyre pressure of 200 kPa (2.0 bar/29 psi) has not been achieved:

- ▶ switch off the tyre inflation compressor.
- ▶ unscrew the filler hose from the valve of the defective tyre.

Please note that tyre sealant may leak out when unscrewing the filler hose.

- ▶ Very slowly drive forwards or reverse approximately 10 m.
- ▶ Pump up the tyre again.
After a maximum of ten minutes the tyre pressure must be at least 200 kPa (2.0 bar/29 psi).

⚠ WARNING Risk of accident due to the specified tyre pressure not being achieved

If the specified tyre pressure is not achieved after the specified time, the tyre is too badly damaged. The tyre sealant cannot repair the tyre in this instance.

Damaged tyres and a tyre pressure that is too low can significantly impair braking and handling characteristics.

- ▶ Do not drive on.
- ▶ Consult a qualified specialist workshop.

If, after ten minutes, a tyre pressure of 200 kPa (2.0 bar/29 psi) has been achieved:

⚠ WARNING Risk of accident from driving with sealed tyres

A tyre temporarily sealed with tyre sealant impairs handling characteristics and is not suitable for higher speeds.

- ▶ Adapt your driving style accordingly and drive carefully.
- ▶ Do not exceed the specified maximum speed with a tyre that has been sealed using tyre sealant.

- ▶ Observe the maximum permissible speed for a tyre sealed with tyre sealant 80 km/h.
- ▶ Fasten the upper section of the TIREFIT sticker to the instrument cluster where it will be easily seen by the driver.

! NOTE Staining from leaking tyre sealant

After use, excess tyre sealant may leak out from the filling hose.

- ▶ Therefore, place the filling hose in the plastic bag that contained the TIREFIT kit.

🌿 ENVIRONMENTAL NOTE Environmental pollution caused by environmentally irresponsible disposal

Tyre sealant contains pollutants.

- ▶ Have the tyre sealant bottle disposed of professionally, e.g. at a Mercedes-Benz Service Centre.

- ▶ Switch off the tyre inflation compressor.
- ▶ Unscrew the filler hose from the valve of the defective tyre.
- ▶ Store the tyre sealant bottle, the tyre inflation compressor and the warning triangle.
- ▶ **Pull away immediately.**
- ▶ Stop after driving for approximately ten minutes and check the tyre pressure using the tyre inflation compressor. The tyre pressure must now be at least 130 kPa (1.3 bar/ 19 psi).

⚠ WARNING Risk of accident due to the specified tyre pressure not being achieved

If the specified tyre pressure is not achieved after a brief drive, the tyre is too badly damaged. The tyre sealant cannot repair the tyre in this instance.

Damaged tyres and a tyre pressure that is too low can significantly impair braking and handling characteristics.

- ▶ Do not drive on.
- ▶ Consult a qualified specialist workshop.

Countries that have Mercedes-Benz

Service24h: a sticker with the phone number can also be found in your vehicle, e.g. on the B-pillar on the driver's side.

- ▶ Correct the tyre pressure if it is still at least 130 kPa (1.3 bar/ 19 psi). See the tyre pressure table on the fuel filler flap for values.
- ▶ **To increase the tyre pressure:** switch on the tyre inflation compressor.

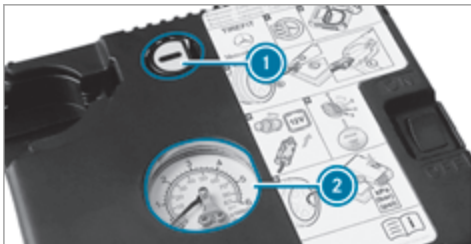

- ▶ **To reduce the tyre pressure:** press pressure release button ① next to manometer ②.
- ▶ When the tyre pressure is correct, unscrew the filler hose from the valve of the sealed tyre.
- ▶ Screw the valve cap onto the tyre valve of the sealed tyre.
- ▶ Pull the tyre sealant bottle out of the tyre inflation compressor. The filler hose stays on the tyre sealant bottle.

- ▶ Drive to the nearest qualified specialist workshop and have the tyre, tyre sealant bottle and filler hose replaced there.

Battery (vehicle)

Notes on the 12 V battery

⚠ WARNING Risk of an accident due to work carried out incorrectly on the battery

Work carried out incorrectly on the battery can, for example, lead to a short circuit. This can lead to function restrictions in safety-relevant systems, e.g. the lighting system, ABS (anti-lock braking system) or ESP® (Electronic Stability Program). The operating safety of your vehicle may be restricted.

You could lose control of the vehicle in the following situations:

- when braking
- in the event of abrupt steering manoeuvres and/or when the vehicle's speed is not adapted to the road conditions

- ▶ In the event of a short circuit or a similar incident, contact a qualified specialist workshop immediately.
- ▶ Do not continue driving.
- ▶ Always have work on the battery carried out at a qualified specialist workshop.

- Further information on ABS (→ page 191)
- Further information on ESP® (→ page 192)

For safety reasons, Mercedes-Benz recommends that you only use batteries which have been tested and approved for your vehicle by Mercedes-Benz. These batteries provide increased impact protection to prevent vehicle occupants from suffering acid burns should the battery be damaged in the event of an accident.

All vehicles except vehicles with a lithium-ion battery

⚠ WARNING Risk of explosion due to electrostatic charge

Electrostatic charge can cause sparks which may ignite the highly flammable gas mixture in the battery.

- ▶ To discharge any electrostatic charge that may have built up, touch the metal vehicle body before handling the battery.

The highly flammable gas mixture is created while the battery is charging and during starting assistance.

⚠ WARNING Danger of chemical burns from the battery acid

Battery acid is caustic.

- ▶ Avoid contact with the skin, eyes or clothing.
- ▶ Do not lean over the battery.

- ▶ Do not inhale battery gases.
- ▶ Keep children away from the battery.
- ▶ Immediately rinse battery acid off thoroughly with plenty of clean water and seek medical attention immediately.

All vehicles

🌿 ENVIRONMENTAL NOTE Environmental damage due to improper disposal of batteries



Batteries contain pollutants. It is illegal to dispose of them with the household rubbish.



▶ Dispose of batteries in an environmentally responsible manner. Take discharged batteries to a qualified

specialist workshop or to a collection point for used batteries.

If you have to connect the 12 volt battery, contact a qualified specialist workshop.

Comply with safety notes and take protective measures when handling batteries.



Risk of explosion



Fire, naked flames and smoking are prohibited when handling the battery. Avoid creating sparks.



Electrolyte or battery acid is corrosive. Avoid contact with the skin, eyes or clothing. Wear suitable protective clothing, in particular gloves, an apron and a face mask. Immediately rinse electrolyte or acid splashes off with clean water. Consult a doctor if necessary.



Wear safety glasses.



Keep children away.



Observe this Owner's Manual.

If you do not intend to use the vehicle over an extended period of time:

- Activate standby mode, or
- Connect the battery to a battery charger approved by Mercedes-Benz, or
- Consult a qualified specialist workshop to disconnect the battery

Starting assistance and charging the 12 V battery

Vehicles with a lithium-ion battery

- ▶ When charging the battery and during starting assistance, always use the jump-start connection point in the engine compartment.

! **NOTE** Damage to the battery from over-voltage

When charging using a battery charger without a maximum charging voltage, the battery or the on-board electronics may be damaged.

- ▶ Only use battery chargers with a maximum charging voltage of 14.4 V.

All other vehicles

- ▶ When charging the battery and during starting assistance, always use the jump-start connection point in the engine compartment.

! **NOTE** Damaging the battery through overvoltage

When using a battery charger without a maximum charging voltage, the battery or the vehicle electronics may be damaged.

- ▶ Only use battery chargers with a maximum charging voltage of 14.8 V.

! **WARNING** Risk of explosion from hydrogen gas igniting

A battery generates hydrogen gas during the charging process. If there is a short circuit or sparks start to form, there is a danger of the hydrogen gas igniting.

- ▶ Make sure that the positive terminal of the connected battery does not come into contact with vehicle parts.
- ▶ Never place metal objects or tools on a battery.
- ▶ When connecting and disconnecting the battery, you must observe the described order for the battery clamps.

- ▶ When giving starting assistance, always make sure that you only connect battery terminals with identical polarity.
- ▶ During starting assistance, you must observe the described order for connecting and disconnecting the jump lead.
- ▶ Do not connect or disconnect the battery clamps while the engine is running.

⚠ WARNING Risk of explosion during charging process and starting assistance

During the charging process and starting assistance, the battery may release an explosive gas mixture.

- ▶ Avoid fire, naked flames, creating sparks and smoking.
- ▶ Make sure that there is sufficient ventilation during the charging process and during starting assistance.
- ▶ Do not lean over a battery.

If the indicator/warning lamps in the instrument cluster do not light up at low temperatures, it is very likely that the discharged battery has frozen.

⚠ WARNING Risk of explosion from a frozen battery

A discharged battery may freeze at temperatures slightly above or below freezing point. During starting assistance or battery charging, battery gas may be released.

- ▶ Always thaw a frozen battery out first before charging it or performing starting assistance.

The service life of a battery that has been thawed may be dramatically shortened.

It is recommended that you have a thawed battery checked at a qualified specialist workshop.

All vehicles

! **NOTE** Damage caused by numerous or extended attempts to start the engine

Numerous or extended attempts to start the engine may damage the catalytic converter due to non-combusted fuel.

- ▶ Avoid numerous and extended attempts to start the engine.

Observe the following points during starting assistance and when charging the battery:

- Only use undamaged jump lead/charging cables with a sufficient cross-section and insulated terminal clamps.
- Non-insulated parts of the terminal clamps must not come into contact with other metal parts while the jump lead/charging cable is connected to the battery/jump-start connection point.
- The jump lead/charging cable must not come into contact with any parts which may move when the engine is running.

- Always make sure that neither you nor the battery is electrostatically charged.
- Keep away from fire and naked flames.
- Do not lean over the battery.
- **When charging:** only use battery chargers tested and approved by Mercedes-Benz and read the battery charger's operating instructions before charging the battery.

Observe the additional following points during starting assistance:

- Starting assistance may only be provided using batteries with a nominal voltage of 12 V.
 - The vehicles must not touch.
 - **Petrol engine:** only accept starting assistance if the engine and exhaust system are cold.
- ▶ Secure the vehicle by applying the electric parking brake.
 - ▶ **Automatic transmission:** shift the transmission to position **P**.
 - ▶ **Manual transmission:** shift into neutral.

- ▶ Make sure that the ignition and all electrical consumers are switched off.
- ▶ Open the engine bonnet.

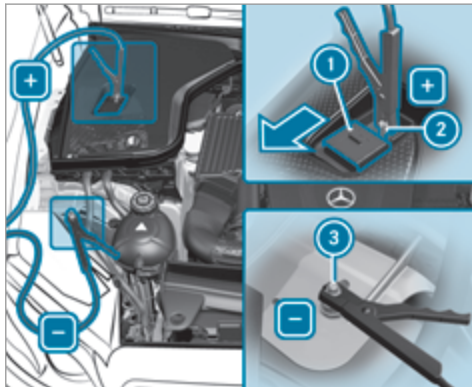

i **Right-hand-drive vehicles:** the jump-starting connection points may be on the opposite side.

- ▶ Slide cover **1** of positive clamp **2** on the jump-starting connection point in the direction of the arrow.
- ▶ Connect positive clamp **2** on your vehicle to positive pole of the donor battery using the jump lead/charging cable. Always begin with positive clamp **2** on your own vehicle first.
- ▶ **During the starting assistance procedure:** start the engine of the donor vehicle and run at idle speed.
- ▶ Connect the negative pole of the donor battery and earth point **3** of your own vehicle by using the jump lead/charging cable. Begin with the donor battery first.
- ▶ **During starting assistance:** start the engine of your own vehicle.
- ▶ **During the charging process:** start the charging process.
- ▶ **During starting assistance:** let the engines run for several minutes.
- ▶ **During starting assistance:** before disconnecting the jump lead, switch on an electrical

consumer in your own vehicle, e.g. the rear window heater or lighting.

When the starting assistance/charging process is complete:

- ▶ First, remove the jump lead/charging cable from earth point ③ and negative pole of the donor battery, then from positive clamp ② and positive pole of the donor battery. Begin

each time with the contacts on your own vehicle first.

- ▶ After removing the jump lead/charging cable, close cover ① of positive clamp ②.

Further information can be obtained at a qualified specialist workshop.

Tow-starting or towing away



Permitted towing methods

Mercedes-Benz recommends transporting your vehicle in the case of a breakdown, rather than towing it away.

! **NOTE** Damage to the vehicle due to towing away incorrectly

- ▶ Observe the instructions and notes on towing away.

Permitted towing methods

Vehicle equipment/towing method	 Both axles on the ground	 Front axle raised	 Rear axle raised
Vehicles with manual transmission	Yes, maximum 50 km at 50 km/h	Yes, maximum 50 km at 50 km/h	Yes, maximum 50 km at 50 km/h
Vehicles with automatic transmission	Yes, maximum 50 km at 50 km/h	No	Yes, if the steering wheel is fixed in the centre position with a steering wheel lock.
4MATIC vehicles	Yes, maximum 50 km at 50 km/h	No	No

Towing with a raised axle: towing should be performed by a towing company.

Towing the vehicle with both axles on the ground

- ▶ Observe the notes on the permitted towing methods (→ page 335) (→ page 336).

- ▶ Make sure that the battery is connected and charged.

When the battery is discharged:

- the engine cannot be started.
- the electric parking brake cannot be released or applied.

- **vehicles with automatic transmission:** the automatic transmission cannot be shifted to position **N** or **P**.

i **vehicles with automatic transmission:** if the automatic transmission cannot be shifted to position **N**, or the multifunction display in the instrument cluster does not show anything, have the vehicle transported away (→ page 338). A towing vehicle with lifting equipment is required for vehicle transportation.

! **NOTE** Damage due to towing away at excessively high speeds or over long distances

The drivetrain could be damaged when towing at excessively high speeds or over long distances.

- ▶ A towing speed of 50 km/h must not be exceeded.
- ▶ A towing distance of 50 km must not be exceeded.

! **WARNING** Risk of accident when towing a vehicle which is too heavy

If the vehicle being tow-started or towed away is heavier than the permissible gross mass, the following situations can occur:

- the towing eye may become detached.
- the car/trailer combination may swerve or even overturn.

▶ If another vehicle is tow-started or towed away, its weight must not exceed the permissible gross mass of your own vehicle.

If a vehicle must be tow-started or towed away, its weight must not exceed the permissible gross mass of the towing vehicle.

- ▶ Information on the permissible gross weight of the vehicle can be found on the vehicle identification plate .
- ▶ **Vehicles with automatic transmission:** do not open the driver's door or front passenger door, otherwise the automatic transmission automatically shifts to position **P**.

- ▶ Fit the towing eye (→ page 340).
- ▶ Attach the tow bar.

! **NOTE** Damage due to incorrect connection

▶ Only connect the tow rope or tow bar to the towing eyes.

- ▶ Deactivate the automatic locking mechanism (→ page 75).
- ▶ Do not activate the HOLD function.
- ▶ Deactivate the tow-away protection (→ page 93).
- ▶ Deactivate Active Brake Assist (→ page 201).
- ▶ **Vehicles with automatic transmission:** shift the automatic transmission to position **N**.
- ▶ **Vehicles with manual transmission:** shift to neutral **N**.
- ▶ Release the electric parking brake.

▶ **Vehicles with manual transmission:** switch on the ignition, otherwise the steering wheel locking may engage.

⚠ WARNING Risk of accident due to limited safety-related functions during the towing process

Safety-related functions are limited or no longer available in the following situations:

- the ignition is switched off.
- the brake system or power steering system is malfunctioning.
- the energy supply or the on-board electrical system is malfunctioning.

When your vehicle is then towed away, significantly more effort may be required to steer and brake than is normally required.

- ▶ Use a tow bar.
- ▶ Make sure that the steering wheel can move freely, before towing the vehicle away.

! **NOTE** Damage due to excessive tractive power

If you pull away sharply, the tractive power may be too high and the vehicles could be damaged.

- ▶ Pull away slowly and smoothly.

Loading the vehicle for transport

- ▶ Observe the notes on towing away (→ page 336).
- ▶ Connect the tow bar to the towing eye to load the vehicle.
- i** You can also attach the tow bar to the trailer hitch.
- ▶ **Vehicles with automatic transmission:** shift the automatic transmission to position **N**.
- i** **Vehicles with automatic transmission:** the automatic transmission may be locked in position **P** in the event of damage to the electrical system. To shift to **N**, provide the

on-board electrical system with power (→ page 332).

- ▶ **Vehicles with manual transmission:** shift to neutral.
- ▶ Load the vehicle onto the transporter.
- ▶ **Vehicles with automatic transmission:** shift the automatic transmission to position **P**.
- ▶ **Vehicles with manual transmission:** engage first or reverse gear.
- ▶ Use the electric parking brake to secure the vehicle and prevent it from rolling away.
- ▶ Only secure the vehicle by the wheels.

Vehicles with ADS PLUS (Adaptive Damping System PLUS)

⚠ WARNING Risk of an accident when transporting vehicles with Adaptive Damping System PLUS

The reduced damping forces on the vehicle being transported can cause the vehicle/trailer combination to start to swing.

As a result, when transporting vehicles with the Adaptive Damping System PLUS, the vehicle/trailer combination may start to skid. Consequently, you could lose control of your vehicle.

- ▶ When transporting, ensure that:
 - the vehicle has been loaded onto the transporter correctly
 - the vehicle is secured at all four wheels with suitable tensioning straps
 - the maximum permissible speed of 60 km/h is not exceeded when transporting

! **NOTE** Damage to the vehicle from securing it incorrectly

- ▶ After loading, the vehicle must be secured on all four wheels. Otherwise, the vehicle could be damaged.
- ▶ A minimum distance of 20 cm upwards and 10 cm downwards must be kept to the transport platform.

- ▶ Secure the vehicle on all four wheels after loading.

4MATIC vehicles/vehicles with automatic transmission

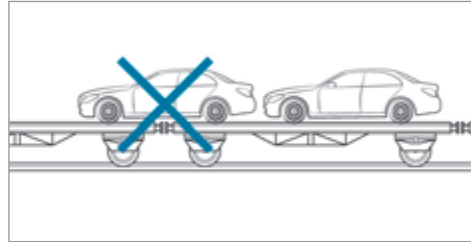

- ▶ Make sure that the front and rear axles come to rest on the same transportation vehicle.

! **NOTE** Damage to the drivetrain due to incorrect positioning

- ▶ Do not position the vehicle above the connection point of the transport vehicle.

Towing eye storage location

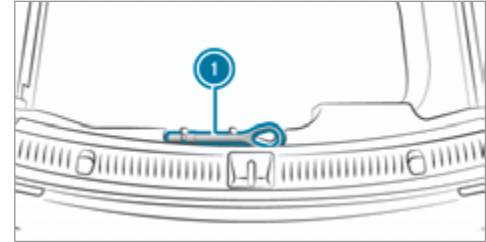

Towing eye ① is attached to the edge of the boot under the boot floor.

Installing the towing eye

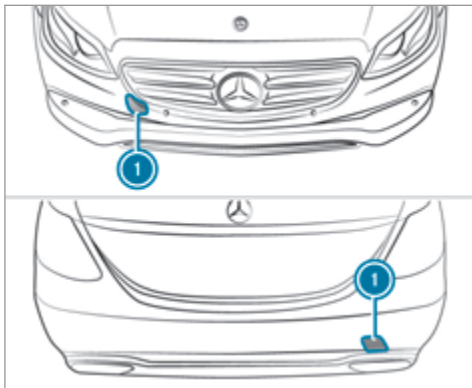

- ▶ Press the mark on cover ① inwards and remove.
- ▶ Screw in the towing eye clockwise as far as it will go and tighten.

Vehicles with a trailer tow hitch: vehicles with a trailer hitch do not have a rear bracket for the

towing eye. Fasten the tow bar to the trailer tow hitch.

- ① Make sure that cover ① engages in the bumper when you remove the towing eye.

! **NOTE** Damage due to incorrect use of the towing eye

When a towing eye is used to recover a vehicle, the vehicle may be damaged in the process.

- ▶ Only use the towing eye to tow away or tow start the vehicle.

Tow-starting the vehicle (emergency engine starting)

Vehicles with automatic transmission

! **NOTE** Damage to the automatic transmission due to tow-starting

The automatic transmission may be damaged in the process of tow-starting vehicles with automatic transmission.

- ▶ Vehicles with automatic transmission must not be tow-started.

- ▶ Vehicles with automatic transmission must not be tow-started.

Vehicles with manual transmission

- ▶ Observe the notes on towing away (→ page 336).
- ▶ If necessary, allow the engine and exhaust system to cool down.
- ▶ Switch the ignition on.
- ▶ Engage second gear.
- ▶ Release the electric parking brake.
- ▶ Tow-start the vehicle while the clutch pedal is fully depressed.
- ▶ Slowly release the clutch pedal.
- ▶ Immediately shift to neutral if the engine starts.
- ▶ Pull over and stop the vehicle, in accordance with the traffic conditions.
- ▶ Remove the tow bar.

- ▶ Remove the towing eye.
- ▶ Have the vehicle checked at a qualified specialist workshop.

Electrical fuses

Notes on electrical fuses

⚠ WARNING Risk of accident and injury due to overloaded lines

If you manipulate or bridge a faulty fuse or if you replace it with a fuse with a higher amperage, the electric line could be overloaded.

This could result in a fire.

- ▶ Always replace faulty fuses with specified new fuses containing the correct amperage.

! NOTE Damage caused by incorrect fuses

Incorrect fuses may cause damage to electrical components or systems.

- ▶ Only use Mercedes-Benz approved fuses with the correct fuse rating.

Blown fuses must be replaced with fuses of the same rating, which you can recognise by the colour and fuse rating. For engine compartment and boot fuses, only use those fuses marked with an "S". The fuse ratings are listed in the fuse assignment diagram.

Fuse assignment diagram: on the fuse box in the boot (→ page 343).

! NOTE Damage or malfunctions caused by moisture

Moisture may cause damage to the electrical system or cause it to malfunction.

- ▶ When the fuse box is open, make sure that no moisture can enter the fuse box.
- ▶ When closing the fuse box, make sure that the seal of the lid is positioned correctly on the fuse box.

If the newly inserted fuse also blows, have the cause traced and rectified at a qualified specialist workshop, e.g. a Mercedes-Benz Service Centre.

Ensure the following before replacing a fuse:

- The vehicle is secured against rolling away.
- All electrical consumers are switched off.
- The ignition is switched off.

The electrical fuses are located in various fuse boxes:

- Fuse box on the driver's side of the engine compartment (→ page 342)
- Fuse box on the driver's side of the cockpit (→ page 343)
- Fuse box in the front-passenger footwell (→ page 343)
- Fuse box in the boot on the right-hand side of the vehicle, when viewed in the direction of travel (→ page 343)

Fuse box in the engine compartment

Observe the notes on electrical fuses
(→ page 341).

Requirements:

- You need a dry cloth and a screwdriver.

Opening

⚠ WARNING Risk of injury from using the windscreen wipers while the engine bonnet is open

When the engine bonnet is open, and the windscreen wipers are set in motion, you can be trapped by the wiper linkage.

- ▶ Always switch off the windscreen wipers and ignition before opening the engine bonnet.

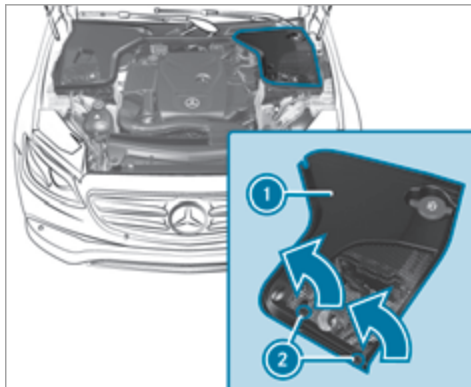

- ▶ Turn clip ② on cover ① a quarter-turn to the left.
- ▶ Pull cover ① upwards in the direction of the arrow.

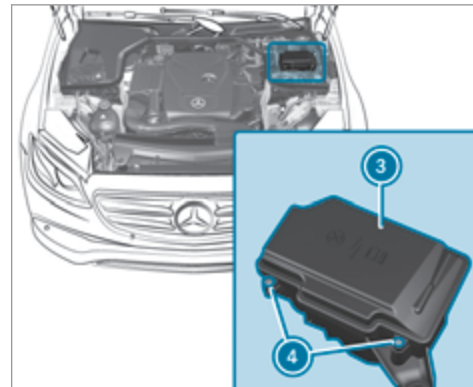

- ▶ Remove any existing moisture from the fuse box using a dry cloth.
- ▶ Loosen screws ④, remove fuse box lid ③ from the top.

Closing

- ▶ Check whether the seal is positioned correctly in the lid.

- ▶ Insert the lid into the bracket at the rear of the fuse box.
- ▶ Fold down lid of the fuse box and tighten screws ④.
- ▶ Insert cover ① on both sides and engage the safety clips.
- ▶ Turn clip ② on cover ① one quarter-turn to the right.
- ▶ Close the engine bonnet.

Fuse box on the dashboard

The fuse box is on the side of the dashboard under a cover.

- ▶ Contact a Mercedes-Benz Service Centre for further information.

Fuse box in the front-passenger footwell

Observe the notes on electrical fuses (→ page 341).

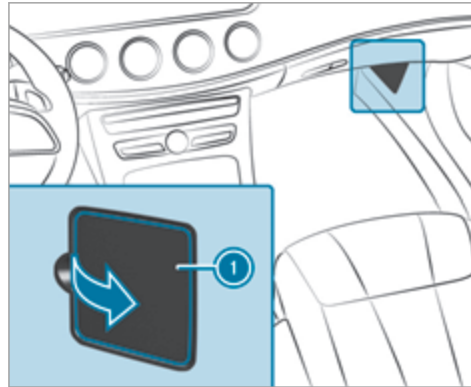

- ▶ Open cover ① in the direction of the arrow and remove it.

Fuse box in the boot

Observe the notes on electrical fuses (→ page 341).



- ▶ Fold cover ① down in the direction of the arrow.

The fuse assignment diagram is in a recess on the side of the fuse box.

Notes on noise or unusual handling characteristics

While driving, pay attention to vibrations, noises and unusual handling characteristics, e.g. pulling to one side. This may indicate that the wheels or tyres are damaged. If you suspect that a tyre is defective, reduce your speed immediately. Stop the vehicle as soon as possible to check the wheels and tyres for damage. Hidden tyre damage could also be causing the unusual handling characteristics. If you find no signs of damage, have the tyres and wheels checked at a qualified specialist workshop.

Regular checking of wheels and tyres

⚠ WARNING Risk of accident from damaged tyres

Damaged tyres can cause tyre pressure loss. As a result, you could lose control of your vehicle.

▶ Check the tyres regularly for signs of damage and replace any damaged tyres immediately.

⚠ WARNING Risk of aquaplaning due to insufficient tyre tread

Insufficient tyre tread will result in reduced tyre grip. The tyre tread is no longer able to dissipate water.

This means that in heavy rain or slush the risk of aquaplaning is increased, in particular where speed is not adapted to suit the conditions.

If the tyre pressure is too high or too low, tyres may exhibit different levels of wear at different locations on the tyre tread.

▶ Thus, you should regularly check the tread depth and the condition of the tread across the entire width of all tyres.

Minimum tread depth for:

- Summer tyres: 3 mm
- M+S tyres: 4 mm

▶ For safety reasons, replace the tyres before the legally prescribed limit for the minimum tread depth is reached.

Carry out the following checks on all wheels regularly, at least once a month or as required, e.g. prior to a long journey or driving off-road:

- Check the tyre pressure (→ page 345).
- Visual inspection of wheels and tyres for damage.
- Check the valve caps.

The valves must be protected against moisture and dirt by the valve caps approved especially for your vehicle by Mercedes-Benz.

- Visual check of the tyre tread depth and the tyre tread condition across the entire width. The minimum tread depth for summer tyres is 3 mm and for winter tyres 4 mm.

Notes on snow chains

⚠ WARNING Risk of accident due to incorrect snow chain fitting

If you have fitted snow chains to the front wheels, the snow chains may drag against the vehicle body or chassis components.

This could cause damage to the vehicle or the tyres.

- ▶ Never fit snow chains on the front wheels.
- ▶ Only fit snow chains on the rear wheels in pairs.

! NOTE Damage to the wheel trim from fitted snow chains

If snow chains are fitted to steel wheels, the wheel trims can be damaged.

- ▶ Remove the wheel trims of steel wheels before fitting snow chains.

- Snow chains are only permissible for certain wheel/tyre combinations. You can obtain

information about this from a Mercedes-Benz Service Centre.

- For safety reasons, only use snow chains that have been specifically approved for your vehicle by Mercedes-Benz, or snow chains with the same quality standard.
 - If snow chains are fitted, the maximum permissible speed is 50 km/h.
 - **Vehicles with Active Parking Assist:** do not use Active Parking Assist when snow chains are fitted.
 - **Vehicles with AIR BODY CONTROL:** only drive at raised vehicle level when snow chains are fitted.
- i** You can permanently limit the maximum vehicle speed for driving with winter tyres (→ page 204).
- i** You can deactivate ESP[®] to pull away (→ page 195). This allows the wheels to spin, achieving an increased driving force.

Tyre pressure

Notes on tyre pressure

⚠ WARNING Risk of accident due to insufficient or excessive tyre pressure

Underinflated or overinflated tyres pose the following risks:

- The tyres may burst, especially as the load and vehicle speed increase.
- The tyres may wear excessively and/or unevenly, which may greatly impair tyre traction.
- The driving characteristics, as well as steering and braking, may be greatly impaired.

▶ Comply with the recommended tyre pressure and check the tyre pressure of all tyres including the spare wheel regularly:

- at least once a month
- when the load changes

- before embarking on a longer journey
 - if operating conditions change, e.g. off-road driving
- ▶ Adjust the tyre pressure as necessary.

Driving with tyre pressure that is too high or too low can:

- Shorten the service life of the tyres.
- Cause increased tyre damage.
- Adversely affect driving characteristics and thus driving safety, e.g. due to aquaplaning.

⚠ WARNING Risk of accident from repeated tyre pressure drop

If the tyre pressure drops repeatedly, the wheel, valve or tyre may be damaged.

Insufficient tyre pressure can cause the tyres to burst.

- ▶ Inspect the tyre for signs of foreign objects.

- ▶ Check whether the wheel or valve has a leak.
- ▶ If you are unable to rectify the damage, contact a qualified specialist workshop.

Information on the recommended tyre pressure for the vehicle's factory-fitted tyres can be found on the tyre pressure table on the inside of the fuel filler flap (→ page 346).

Use a suitable pressure gauge to check the tyre pressure. The outer appearance of a tyre does not permit any reliable conclusion about the tyre pressure.

Vehicles with a tyre pressure monitoring system: you can also check the tyre pressure using the on-board computer.

Only correct tyre pressures when the tyres are cold. Conditions for cold tyres:

- The vehicle has been parked with the tyres out of direct sunlight for at least three hours.
- The vehicle has travelled less than 1.6 km.

A rise in the tyre temperature of 10 °C increases the tyre pressure by approx. 10 kPa (0.1 bar/

1.5 psi). Take this into account when checking the tyre pressure of warm tyres.

Trailer operation notes

Always inflate the rear axle tyres to the recommended tyre pressures on the tyre pressure table for increased load.

Tyre pressure table

The tyre pressure table is on the inside of the fuel filler flap.

		kPa		psi	
FRONT LEFT	100	100	100	100	100
	100	100	100	100	100
FRONT RIGHT	100	100	100	100	100
	100	100	100	100	100
REAR LEFT	100	100	100	100	100
	100	100	100	100	100
REAR RIGHT	100	100	100	100	100
	100	100	100	100	100

A 213 584 37 03 1234567

The tyre pressure table shows the recommended tyre pressure for all tyres approved for this vehicle. The recommended tyre pressures apply for cold tyres under various operating conditions, i.e. loading and/or speed of the vehicle.

If one or more tyre sizes precede a tyre pressure, the tyre pressure information following is only valid for those tyre sizes.

If the preceding tyre sizes are complemented by the symbol, the tyre pressure information following shows alternative tyre pressures. These tyre pressures may improve your vehicle's ride comfort. Fuel consumption may then increase slightly.

The load conditions "partially laden" and "fully laden" are defined in the table for different numbers of passengers and amounts of luggage. The actual number of seats may differ from this.

Be sure to also observe the following further related subjects:

- Notes on tyre pressure (→ page 345)

Tyre pressure monitoring system

Function of the tyre pressure monitoring system

The system checks the tyre pressure and the tyre temperature of the tyres fitted to the vehicle by means of a tyre pressure sensor.

New tyre pressure sensors, e.g. in winter tyres, are automatically taught-in the first time they are driven.

The tyre pressure and the tyre temperature appear in the multifunction display (→ page 255).

If there is a substantial pressure loss or if the tyre temperature is excessive, a warning will be given:

- Via display messages (→ page 417).
- Via the warning lamp in the instrument cluster (→ page 454).

It is the driver's responsibility to set the tyre pressure to the recommended cold tyre pressure suitable for the operating situation. Set the tyre pressure for cold tyres using a tyre pressure gauge. Note that the correct tyre pressure for the current operating situation must first be taught-in to the tyre pressure monitoring system.

In most cases, the tyre pressure monitoring system will automatically update the new reference values after you have changed the tyre pressure. You can, however, also update the reference values by restarting the tyre pressure monitoring system manually (→ page 348).

System limitations

The system may be impaired or may not function in the following situations:

- If the tyre pressure is set incorrectly.
- If there is a sudden pressure loss caused, for example, by a foreign object penetrating the tyre.
- If there is a malfunction caused by another radio signal source.

Make sure to observe the following further related subject:

- Notes on tyre pressure (→ page 345)

Checking the tyre pressure with the tyre pressure monitoring system

Requirement:

- The ignition is switched on.

On-board computer:

↪ Service ▶ Tyres

One of the following displays appears:

- Current tyre pressure and tyre temperature of the individual wheels:

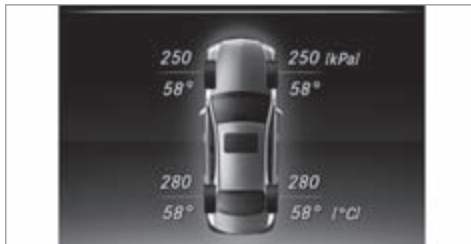

- Tyre pressures will be displayed after a few minutes of driving
- Tyre pressure monitor active: the teach-in process of the system is not yet complete. The tyre pressures are already being monitored.

▶ Compare the tyre pressure with the recommended tyre pressure for the current operating condition (→ page 346). Observe the notes on tyre temperature (→ page 345).

ⓘ The values displayed in the multifunction display may deviate from those of the tyre pressure gauge as they refer to sea level. At high altitudes, the tyre pressure values indicated

by pressure gauges are higher than those shown by the on-board computer. In this case, do not reduce the tyre pressure.

Make sure to observe the following further related subject:

- Notes on tyre pressure (→ page 345)

Restarting the tyre pressure monitoring system

Requirement:

- The recommended tyre pressure is correctly set for the respective operating condition on each of the four wheels (→ page 345).

Restart the tyre pressure monitoring system in the following situations:

- The tyre pressure has changed.
- The wheels or tyres have been changed or newly fitted.

On-board computer:

↪ Service ▶ Tyres

- ▶ Swipe downwards on Touch Control on the left-hand side of the steering wheel. The **Use current pressures as new reference values** message is shown in the multifunction display.
- ▶ Press **OK** to confirm the restart. The **Tyre press. monitor restarted** message is shown in the multifunction display. Current warning messages are deleted and the **(U)** yellow warning lamp goes out. After you have driven for a few minutes, the system checks whether the current tyre pressures are within the specified range. The current tyre pressures are then accepted as reference values and monitored.

Make sure to observe the following further related subject:

- Notes on tyre pressure (→ page 345)

Radio-equipment approval of the tyre pressure monitoring system

Radio equipment approval numbers

Country	Radio equipment approval number
Abu Dhabi	TRA REGISTERED NO: ER37156/15. DEALER NO: DA0047074/10
Argentina	AFTIC:H14788
Dubai	TRA REGISTERED NO: ER37156/15. DEALER NO: DA0047074/10
European Union	Schrader Electronics Ltd. 11 Technology Park, Belfast Road, Antrim BT41 1QS, Northern Ireland

Country	Radio equipment approval number
Jordan	Kingdom of Jordan Type approval for Tyre Pressure sensor. Manufacturer: Schrader Electronics Ltd. Model: AG5SP4 Type Approval Number: TRC/LPD/2015/21 Kingdom of Jordan Type approval for Tyre Pressure sensor. Manufacturer: Schrader Electronics Ltd. Model: MFR Type Approval Number: TRC/LPD/2015/223
Malaysia	RCDD/04A/0615/S(15-2095)
Morocco	AGREE PAR L'ANRT MAROC Numero d'agrement :MR 10216 ANRT 2015 Date d'agrement :18/3/2015

Country	Radio equipment approval number
Mexico	IFT:RCPSCAG 15-0627 IFT:RLVSCMF 15-0959
Moldova	
Philippines	 NTC Type Approved. No:ESD-1510576CNTC
Serbia	
Singapore	Complies with IDA Standards DA 105282

Country	Radio equipment approval number
South Africa	 TA-2015/072 Approved TA-2015/117 Approved

Country	Radio equipment approval number
Ukraine	 Schrader Electronics цім стверджує, що обладнання Радіопередавач моделі AG5SP4 системи контролю тиску в шині автомобіля відповідає вимогам Технічного регламенту радіообладнання і телекомунікаційного кінцевого (термінального) обладнання (Постанова КМУ № 679 від 24 червня 2009 р.) Декларація відповідності знаходиться на сайті Schrader Electronics та надається за запитом на електронну адресу emc-team@schrader.co.uk Schrader Electronics цім стверджує, що обладнання

Country	Radio equipment approval number
	Радіопередавач моделі MFR системи контролю тиску в шині автомобіля відповідає вимогам Технічного регламенту радіообладнання і телекомунікаційного кінцевого (термінального) обладнання (Постанова КМУ № 679 від 24 червня 2009 р.) Декларація відповідності знаходиться на сайті Schrader Electronics та надається за запитом на електрону адресу emc-team@schrader.co.uk
United Arab Emirates	TRA REGISTERED NO :ER37156 / 15. DEALER NO:DA0047074 / 10

Brazil



Este equipamento opera em caráter secundário, isto é, não tem direito à proteção contra interferência prejudicial, mesmo de estações do mesmo tipo, e não pode causar interferência a sistemas operando em caráter primário.

Vietnam



Tyre pressure loss warning system

Function of the tyre pressure loss warning system

The tyre pressure loss warning system warns the driver by means of display messages when there is a severe tyre pressure loss.

After a change in tyre pressure, a wheel rotation or a wheel change, the tyre pressure loss warning system has to be taught-in again by being restarted (→ page 352).

The tyre pressure loss warning system does not replace the need to regularly check the tyre pressures.

System limitations

The system may be impaired or may not function in the following situations:

- If the tyre pressure is set incorrectly.
- If there is a sudden pressure loss caused, for example, by a foreign object penetrating the tyre.
- If the pressure loss in several tyres decreases at the same rate.

The system has a limited or delayed function:

- When the road surface is poor, e.g. snow or gravel.
- When driving with snow chains.
- When driving in a very sporty driving style with high cornering speeds or sudden acceleration.
- When towing a very heavy or large trailer.
- When driving with a high load.

Be sure to also observe the following further related subjects:

- Notes on tyre pressure (→ page 345)
- Display messages about the tyres (→ page 417)

Restarting the tyre pressure loss warning system

Requirement:

- The recommended tyre pressure is correctly set for the respective operating condition on each of the four wheels (→ page 345).

On-board computer:

↪ Service ▶▶ Tyres

The **Run Flat Indicator activeRestart with OK** message is shown in the multifunction display.

Restart the tyre pressure loss warning system in the following situations:

- The tyre pressure has changed.
- The wheels or tyres have been changed or newly fitted.

▶ Press **OK** to begin the new start. The **Tyre pressure now OK?** message is shown in the multifunction display.

▶ Select **Yes**.

▶ Press **OK** to confirm the restart. The **Run Flat Indicator restarted** message is shown in the multifunction display.

After you have driven for a few minutes, the tyre pressure loss warning system monitors the set tyre pressures of all the tyres.

Be sure to also observe the following further related subjects:

- Notes on tyre pressure (→ page 345)

Wheel change

Notes on selecting, fitting and replacing tyres

Mercedes-AMG vehicles: observe the notes in the Supplement. Otherwise, you may fail to recognise dangers.

You can ask for information regarding permitted wheel/tyre combinations at a Mercedes-Benz Service Centre.

⚠ WARNING Risk of accident due to incorrect dimensions of wheels and tyres

If wheels and tyres of the wrong size are used, the wheel brakes or wheel suspension components may become damaged.

- ▶ Always replace wheels and tyres with those that fulfil the specifications of the original part.

When replacing wheels, make sure to fit the correct:

- Designation
- Type

When replacing tyres, make sure to fit the correct:

- Designation
- Manufacturer
- Type

⚠ WARNING Risk of injury through exceeding the specified tyre load-bearing capacity or the permissible speed rating

Exceeding the specified tyre load-bearing capacity or the permissible speed rating may lead to tyre damage and to the tyres bursting.

- ▶ Therefore, only use tyre types and sizes approved for your vehicle model.
- ▶ Observe the tyre load-bearing capacity rating and speed rating required for your vehicle.

! NOTE Damage to vehicle and tyres due to non-approved tyre types and sizes

For safety reasons, only use wheels, tyres and accessories which have been approved for your vehicle by Mercedes-Benz.

These tyres have been specially adapted for use with the control systems, e.g. ABS or ESP®, and are marked as follows:

- MO = Mercedes-Benz Original
- MOE = Mercedes-Benz Original Extended (run-flat tyres only for certain wheels)
- MO1 = Mercedes-Benz Original (only certain AMG tyres)

Certain characteristics, e.g. handling, vehicle noise emissions or fuel consumption, may otherwise be adversely affected. In addition, when driving with a load, tyre dimension variations could cause the tyres to come into contact with the body and axle components. This could result in damage to the tyres or the vehicle.

Only use tyres, wheels or accessories tested and approved by Mercedes-Benz.

! **NOTE** Risk to driving safety from retreaded tyres

Retreaded tyres are neither tested nor recommended by Mercedes-Benz, since previous damage cannot always be detected on retreaded tyres.

For this reason driving safety cannot be guaranteed.

- ▶ Do not use used tyres if you have no information about their previous usage.

! **NOTE** Possible damage to wheels or tyres when driving over obstacles

Large wheels have a lower tyre section width. The lower the tyre section width, the greater is the risk of damage to wheels or tyres when driving over obstacles.

- ▶ Avoid obstacles or drive particularly carefully.

! **NOTE** Damage to electronic component parts from the use of tyre-fitting tools

Vehicles with a tyre pressure monitoring system: electronic component parts are located in the wheel. Tyre-fitting tools should not be applied in the area of the valve.

The tools could damage the electronic component parts.

- ▶ Have the tyres changed at a qualified specialist workshop only.

! **NOTE** Damage to summer tyres at low ambient temperatures

Using summer tyres at very low ambient temperatures can cause cracks to form, thereby damaging the tyres permanently.

- ▶ At temperatures below 7 °C use M+S-tyres.

Accessory parts that are not approved for your vehicle by Mercedes-Benz or are not being used correctly can impair the operating safety.

Before purchasing and using non-approved accessories, visit a qualified specialist workshop and enquire about:

- Suitability
- Legal stipulations
- Factory recommendations

! **WARNING** Risk of accident with high performance tyres

The special tyre tread in combination with the optimised tyre compound, means that the risk of skidding or hydroplaning on wet roads is increased.

In addition, the tyre grip is greatly reduced at a low outside temperature and tyre running temperature.

- ▶ Switch on the ESP® and adapt your driving style accordingly.
- ▶ Use M+S tyres at outside temperatures of less than 50 °F.

Observe the following when selecting, fitting and replacing tyres:

- Country-specific requirements for tyre approval that define a specific tyre type for your vehicle.

Furthermore, the use of certain tyre types in certain regions and areas of operation can be highly beneficial.

- Only use tyres and wheels of the same type (summer tyres, winter tyres, MOExtended tyres) and the same make.
- Only fit wheels of the same size on one axle (left and right).

It is only permissible to fit a different wheel size in the event of a flat tyre in order to drive to the specialist workshop.

- Only fit tyres of the correct size onto the wheels.
- Do not make any modifications to the brake system, the wheels or the tyres.

The use of shims or brake dust shields is not permitted and may invalidate the vehicle's general operating permit.

- **Vehicles with a tyre pressure monitoring system:** all fitted wheels must be equipped with functioning sensors for the tyre pressure monitoring system.
- At temperatures below 7 °C, use winter tyres or all-season tyres marked M+S for all wheels.

Winter tyres bearing the  snowflake symbol in addition to the M+S marking provide the best possible grip in wintry road conditions.

- For M+S tyres, only use tyres with the same tread.
- Observe the maximum permissible speed for the M+S tyres fitted.

If this is below the vehicle's maximum speed, this must be indicated in an appropriate label in the driver's field of vision.

- Run in new tyres at moderate speeds for the first 100 km.
- Replace the tyres after six years at the latest, regardless of wear.

- **When replacing with tyres that do not feature run-flat characteristics:** vehicles with MOExtended tyres are not equipped with a TIREFIT kit at the factory. Equip the vehicle with a TIREFIT kit after replacing with tyres that do not feature run-flat characteristics, e.g. winter tyres.

For more information on wheels and tyres, contact a qualified specialist workshop.

Be sure to also observe the following further related subjects:

- Notes on tyre pressure (→ page 345)
- Tyre pressure table (→ page 346)
- Notes on the emergency spare wheel (→ page 362)

Notes on interchanging wheels

 **WARNING** Risk of injury through different wheel sizes

Interchanging the front and rear wheels if the wheels or tyres have different dimensions

may severely impair the driving characteristics.

The disk brakes or wheel suspension components may also be damaged.

- ▶ Rotate front and rear wheels only if the wheels and tyres are of the same dimensions.

Interchanging the front and rear wheels if the wheels or tyres have different dimensions can render the general operating permit invalid.

The wear patterns on the front and rear wheels differ:

- Front wheels wear more on the shoulder of the tyre
- Rear wheels wear more in the centre of the tyre

On vehicles with the same front and rear wheel size, you can interchange the wheels every 5,000 to 10,000 km, depending on the wear. Ensure the direction of rotation is maintained for the wheels.

It is imperative to observe the instructions and safety notes on "Wheel change" when doing so.

Notes on storing wheels

- After removing wheels, store them in a cool, dry and preferably dark place.
- Protect the tyres from contact with oil, grease or fuel.

Overview of the tyre-change tool kit

Apart from some country-specific variants, vehicles are not equipped with a tyre-change tool kit. For more information on which tyre-changing tool kit are required and approved for performing a wheel change on your vehicle, consult a qualified specialist workshop.

Required tyre-change tool kit may include, for example:

- jack
- chock
- wheel wrench
- centring pin

- ⓘ The jack weighs approximately 3.4 kg. The maximum payload of the jack can be found on the sticker affixed to the jack. The jack is maintenance-free. If there is a malfunction, please contact a qualified specialist workshop.

The tyre-change tool kit is located under the boot floor.

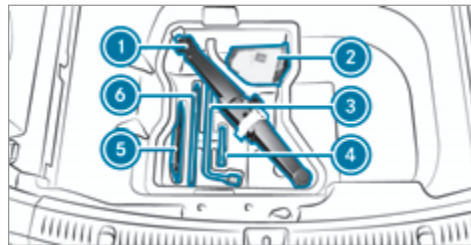

- ① Jack
- ② Gloves
- ③ Wheel wrench
- ④ Centring pin

- ⑤ Folding chock
- ⑥ Ratchet for jack

Setting up the folding wheel chock

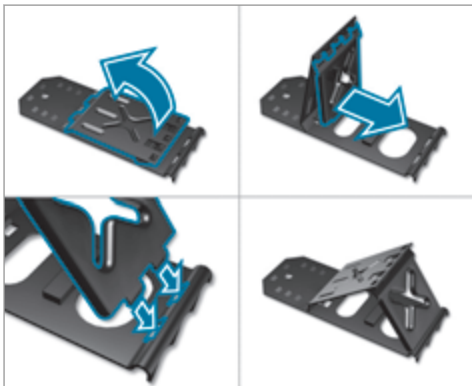

Preparing the vehicle for a wheel change

Requirements:

- The required tyre-change tool kit is available. If your vehicle is not equipped with the tyre-change tool kit, consult a qualified specialist workshop to find out about suitable tools.
 - The vehicle is not on a slope.
 - The vehicle is on solid, non-slippery and level ground.
- ▶ Apply the electric parking brake manually.
 - ▶ Move the front wheels to the straight-ahead position.
 - ▶ **Vehicles with manual transmission:** engage first or reverse gear.
 - ▶ **Vehicles with automatic transmission:** shift into position **P**.
 - ▶ **Vehicles with AIR BODY CONTROL:** set the normal vehicle level (→ page 215).
 - ▶ Switch off the engine.
 - ▶ Make sure that the engine cannot be started.

- ▶ Place chocks or other suitable items under the front and rear of the wheel that is diagonally opposite the wheel you wish to change.
- ▶ Remove the hub caps if necessary (→ page 357).
- ▶ Raising the vehicle (→ page 358).

Removing and fitting hub caps

Requirement:

- The vehicle is prepared for a wheel change (→ page 357).

Plastic hub cap

- ▶ **To remove:** turn the centre cover of the hub cap anti-clockwise and remove the hub cap.
- ▶ **To fit:** make sure that the centre cover of the hub cap is turned anti-clockwise.
- ▶ Position the hub cap and turn the centre cover clockwise until the hub cap engages physically and audibly.

Aluminium hub cap

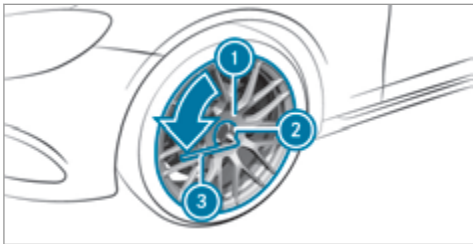

▶ **To remove:** position socket ② on hub cap ①.

① The socket can be found in the tyre-change tool kit.

▶ Position wheel spanner ③ on socket ②.

▶ Using wheel spanner ③, turn hub cap ① anti-clockwise and remove it.

▶ **To fit:** position hub cap ① and turn until it is completely flush with the wheel.

▶ Position socket ② on hub cap ①.

▶ Attach wheel spanner ③ to socket ② and tighten the hub cap clockwise.

Specified tightening torque: 25 Nm.

▶ Raise the vehicle (→ page 358).

Raising the vehicle when changing a wheel

Requirements:

- There are no persons in the vehicle.
- The vehicle has been prepared for a wheel change (→ page 357).
- The hub caps have been removed (→ page 357).

Important notes on using the jack:

- only use the vehicle-specific jack that has been tested and approved by Mercedes-Benz to raise the vehicle.
- the jack is only designed for raising and holding the vehicle for a short time while a wheel is being changed and not for maintenance work under the vehicle.

- the jack must be placed on a firm, flat and non-slip surface. If necessary, use a large, load-bearing, non-slip underlay.
- the foot of the jack must be positioned vertically under the jacking point.

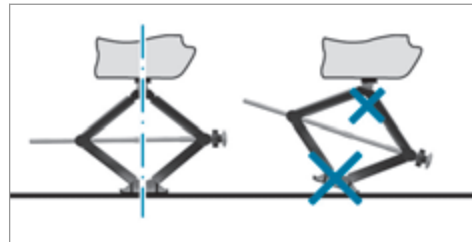

Rules of conduct when the vehicle is raised:

- Never place your hands or feet under the vehicle.
- Do not lie under the vehicle.
- Do not start the engine and do not release the electric parking brake.
- Do not open or close any doors or the boot lid.

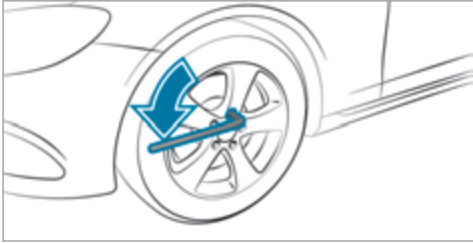

- ▶ Using the wheel wrench, loosen the wheel bolts on the wheel you wish to change by about one full turn. Do not unscrew the bolts completely.

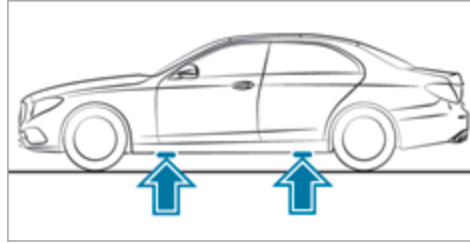

Position of jack support points

⚠ WARNING Risk of injury from incorrect positioning of the jack

If you do not position the jack correctly at the appropriate jacking point of the vehicle, the jack could tip with the vehicle raised.

- ▶ Only position the jack at the appropriate jacking point of the vehicle. The base of the jack must be positioned vertically under the jacking point of the vehicle.

! NOTE Vehicle damage from the jack

If you do not position the jack correctly at the appropriate jack support point of the vehicle, the jack could tip over with the vehicle raised.

- ▶ The jack is designed exclusively for jacking up the vehicle at the jack support points.

- ▶ Take the ratchet ring spanner out of the tyre-change tool kit and place it on the hexagon nut of the jack so that the lettering "AUF" is visible.

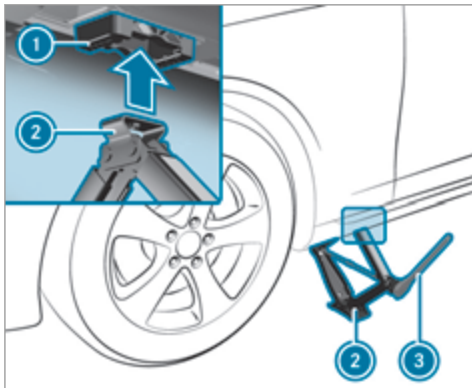

- ▶ Position jack ② at jack support point ①.
- ▶ Turn ratchet ring spanner ③ clockwise until jack ② sits completely on jack support point ① and the base of the jack lies evenly on the ground.
- ▶ Continue to turn ratchet ring spanner ③ until the tyre is raised a maximum of 3 cm off the ground.
- ▶ Loosen and remove the wheel (→ page 360).

Removing a wheel

Requirement:

- The vehicle is raised (→ page 358).

When changing a wheel, avoid applying any force to the brake discs, since this could impair the level of comfort when braking.

! **NOTE** Damage to threading from dirt on wheel bolts

▶ Do not place wheel bolts in sand or on a dirty surface.

▶ Unscrew the uppermost wheel bolt completely.

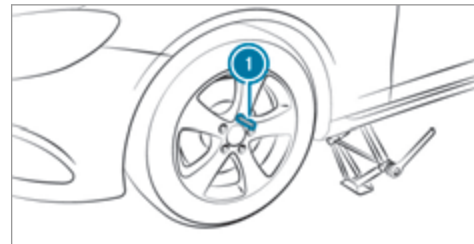

- ▶ Screw centring pin ① instead of the wheel bolt into the threading.
- ▶ Unscrew the remaining wheel bolts fully.
- ▶ Remove the wheel.
- ▶ Fit the new wheel (→ page 360).

Fitting a new wheel

Requirement:

- The wheel is removed (→ page 360).

⚠ WARNING Risk of accident from losing a wheel

Oiled, greased or damaged wheel bolt/wheel nut threads or wheel hub/wheel mounting bolt threads can cause the wheel bolts/wheel nuts to come loose.

As a result, you could lose a wheel while driving.

- ▶ Never oil or grease the threads.
- ▶ In the event of damage to the threads, contact a qualified specialist workshop immediately.
- ▶ Have the damaged wheel bolts or damaged hub threads replaced.
- ▶ Do not continue driving.

- ▶ Observe the information on the choice of tyres (→ page 352).

For tyres with a specified direction of rotation, an arrow on the side wall of the tyre indicates the correct direction of rotation. Observe the direction of rotation when fitting.

- ▶ Slide the wheel to be mounted onto the centring pin and push it on.

⚠ WARNING Risk of injury from tightening wheel bolts and nuts

If you tighten the wheel bolts or wheel nuts when the vehicle is raised, the jack could tip.

- ▶ Only tighten wheel bolts or wheel nuts when the vehicle is on the ground.
- ▶ For safety reasons, only use wheel bolts which have been approved by Mercedes-Benz and for the wheel in question.
- ▶ Tighten the wheel bolts until they are finger-tight.
- ▶ Unscrew the centring pin.
- ▶ Tighten the last wheel bolt until it is finger-tight.
- ▶ Lower the vehicle (→ page 361).

Lowering the vehicle after a wheel change

Requirements:

- The new wheel has been fitted (→ page 360).
- ▶ Place the ratchet ring spanner onto the hexagon nut of the jack so that the lettering "AB" is visible.
- ▶ **To lower the vehicle:** turn the ratchet ring spanner of the jack anti-clockwise.

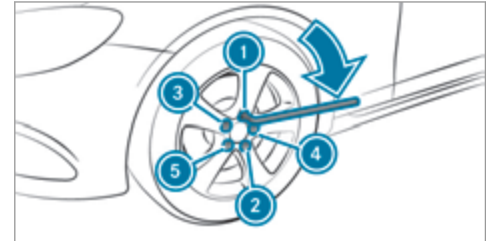

- ▶ Tighten the wheel bolts evenly in a diagonal pattern in the order indicated (① to ⑤).
Specified tightening torque: 150 Nm.

⚠ WARNING Risk of accident due to incorrect tightening torque

The wheels could come loose if the wheel bolts or wheel nuts are not tightened to the prescribed torque.

- ▶ Have the tightening torque checked immediately at a qualified specialist workshop after changing a wheel.

- ▶ Check the tyre pressure of the newly mounted wheel and adjust accordingly.
- ▶ **Vehicles with tyre pressure loss warning system:** restart the tyre pressure loss warning system (→ page 352).
Exception: the new wheel is an emergency spare wheel.
- ▶ **Vehicles with a tyre pressure monitoring system:** restart the tyre pressure monitoring system (→ page 348).
Exception: the new wheel is an emergency spare wheel.

Make sure to observe the following further related subject:

- Notes on tyre pressure (→ page 345)

Emergency spare wheel

Notes on the emergency spare wheel

⚠ WARNING Risk of accident caused by incorrect wheel and tyre dimensions

The wheel or tyre size and the tyre type of the emergency spare wheel or spare wheel and the wheel to be replaced may differ. Mounting an emergency spare wheel/spare wheel may severely impair the driving characteristics.

To prevent hazardous situations:

- ▶ Adapt your driving style accordingly and drive carefully.
- ▶ Never fit more than one emergency spare wheel or spare wheel that differs in size.

- ▶ Only use an emergency spare wheel or spare wheel of a different size briefly.
- ▶ Do not switch off ESP®.
- ▶ >Have the emergency spare wheel or spare wheel of a different size replaced at the nearest qualified specialist workshop. The new wheel must have the correct dimensions.

Check the tyre pressure of the emergency spare wheel fitted. Correct the pressure as necessary.

The maximum permissible speed with an emergency spare wheel fitted is 80 km/h.

Do not fit the emergency spare wheel with snow chains.

Replace the emergency spare wheel after six years at the latest, regardless of wear.

- ⓘ **Vehicles with a tyre pressure loss warning system:** If an emergency spare wheel is fitted the tyre pressure loss warning system cannot function reliably. Only restart the system again when the emergency spare wheel has been replaced with a new wheel.

Vehicles with a tyre pressure monitoring system: If an emergency spare wheel is fitted the tyre pressure monitoring system cannot function reliably. Only restart the system again when the emergency spare wheel has been replaced with a new wheel.

Vehicles with a tyre pressure monitoring system: For a few minutes after an emergency spare wheel is fitted, the system may still display the tyre pressure of the removed wheel.

Be sure to also observe the following further related subjects:

- Notes on tyre pressure (→ page 345)
- Tyre pressure table (→ page 346)

Removing the emergency spare wheel

The emergency spare wheel is secured in the emergency spare wheel bag in the boot.

- ▶ Observe the information on mounting tyres (→ page 352).
- ▶ Open the boot.

- ▶ Detach the fastening straps.
- ▶ Unhook the retaining spring hooks of the fastening straps from the brackets.
- ▶ Remove the emergency spare wheel bag with the emergency spare wheel.
- ▶ Open the emergency spare wheel bag and remove the emergency spare wheel.

Notes on technical data

Mercedes-AMG vehicles: be sure to observe the notes in the Supplement. Otherwise, you may fail to recognise dangers.

The technical data was determined in accordance with EU Directives. The data stated only applies to vehicles with standard equipment. You can obtain further information from a Mercedes-Benz Service Centre.

Only for certain countries: you can find vehicle-specific vehicle data in the COC documents (CERTIFICATE OF CONFORMITY). These documents are delivered with your vehicle.

On-board electronics

Notes on tampering with the engine electronics

! **NOTE** Premature wear through improper maintenance

Improper maintenance may cause vehicle components to wear more quickly and the

vehicle's operating permit may be invalidated.

- ▶ Always have work on the engine electronics and related components carried out at a qualified specialist workshop.

Two-way radios

Notes on installing two-way radios

! **WARNING** Risk of accident due to improper work on two-way radios

The electromagnetic radiation from two-way radios can interfere with the on-board electronics if RF transmitters are manipulated or retrofitted incorrectly.

This could jeopardise the operating safety of the vehicle.

- ▶ You should have all work on electrical and electronic components carried out at a qualified specialist workshop.

! **WARNING** Risk of accident from incorrect operation of two-way radios

If you operate two-way radios incorrectly in the vehicle, the electromagnetic radiation could interfere with the on-board electronics, e.g.:

- if the two-way radio is not connected to an exterior aerial
- if the exterior aerial is not correctly mounted or is not of low reflection

This could jeopardise the operating safety of the vehicle.

- ▶ Have the low-reflection exterior aerial fitted at a qualified specialist workshop.
- ▶ When operating two-way radios in the vehicle, always connect them to the low-reflection exterior aerial.

! **NOTE** Invalidation of the operating permit due to failure to comply with the instructions for installation and use

The operating permit may be invalidated if the instructions for installation and use of two-way radios are not observed.

- ▶ Only use approved frequency bands.
- ▶ Observe the maximum permissible output power in these frequency bands.
- ▶ Only use approved aerial positions.

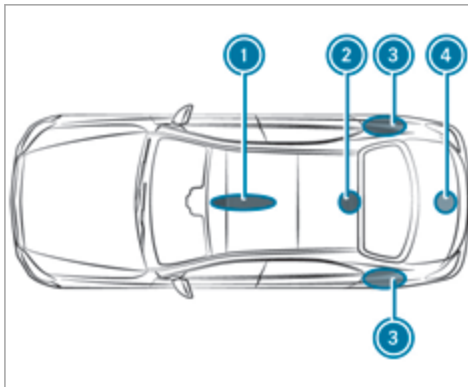

- ① Front roof area
- ② Rear roof area
- ③ Rear wing
- ④ Boot lid

On vehicles with a panoramic sliding sunroof, installing an aerial to the front or rear roof area is not permitted.

On the rear wings, it is recommended that you install the aerial on the side of the vehicle closest to the centre of the road.

Use Technical Specification ISO/TS 21609 (Road Vehicles - "EMCs for installation of aftermarket radio frequency transmitting equipment") when retrofitting two-way radios. Comply with the legal requirements for detachable parts.

If your vehicle has fittings for two-way radio equipment, use the power supply or aerial connectors intended for use with the basic wiring. Be sure to observe the manufacturer's Supplements when installing.

Two-way radio transmission output

The maximum transmission output (PEAK) at the base of the aerial must not exceed the values in the following table:

frequency band and maximum transmission output

Frequency band	Maximum transmission output
Short wave 3 - 54 MHz	100 W
4 m frequency band 74 - 88 MHz	30 W
2 m frequency band 144 - 174 MHz	50 W
Trunked radio system/Tetra 380 - 460 MHz	10 W
70 cm frequency band 420 - 450 MHz	35 W
Two-way radio (2G/3G/4G)	10 W

The following can be used in the vehicle without restrictions:

- two-way radios with a maximum transmission output of up to 100 mW
- two-way radios with transmitter frequencies in the 380 - 410 MHz frequency band and a maximum transmission output of up to 2 W (trunked radio system/Tetra)
- mobile phones (2G/3G/4G)

There are no restrictions when positioning the aerial on the outside of the vehicle for the following frequency bands:

- trunked radio system/Tetra
- 70 cm frequency band
- 2G/3G/4G

Vehicle identification plate, VIN and engine number

Vehicle identification plate

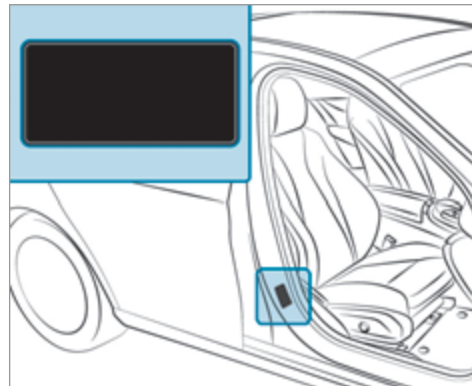

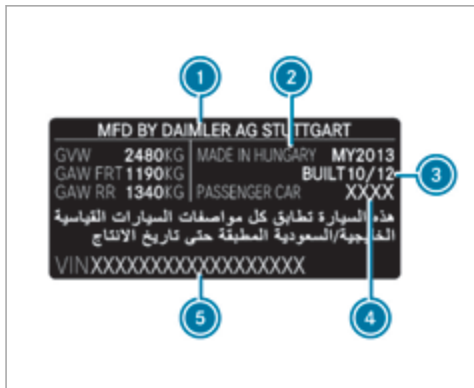

Vehicle identification plate (example: Kuwait)

- ① Vehicle manufacturer
- ② Place of manufacture
- ③ Manufacturing date
- ④ Type of vehicle
- ⑤ VIN

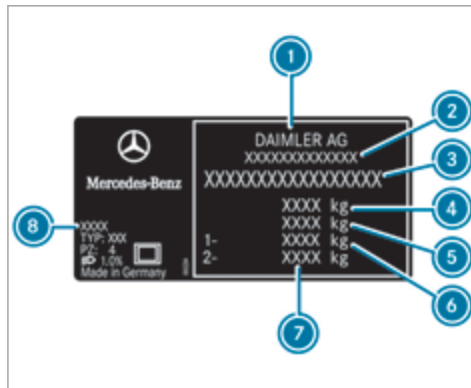

Vehicle identification plate (example: all other countries)

- ① Vehicle manufacturer
- ② EU general operating permit number (only for certain countries)
- ③ VIN (vehicle identification number)
- ④ Maximum gross vehicle weight (kg)
- ⑤ Maximum gross vehicle weight of vehicle combination (kg) (only for specific countries)
- ⑥ Permissible front axle load (kg)
- ⑦ Permissible rear axle load (kg)
- ⑧ Paint code number

- ⑥ Permissible front axle load (kg)
- ⑦ Permissible rear axle load (kg)
- ⑧ Paint code number
- i The data shown in the illustration is example data.

VIN in front of the right-hand front seat

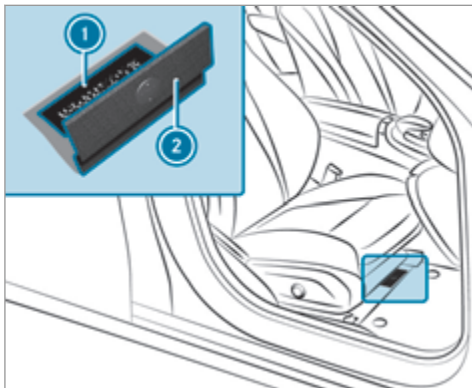

- ① VIN (vehicle identification number)
- ② Floor covering

VIN at the lower edge of the windscreen

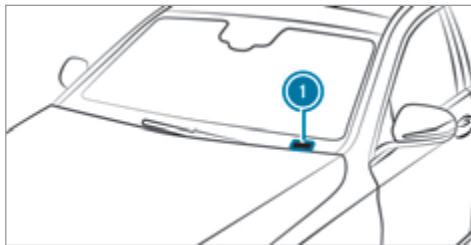

- ① VIN (vehicle identification number)

The VIN at the lower edge of the windscreen is only available in some countries.

Engine number

The engine number is stamped into the crankcase. You can obtain further information from any qualified specialist workshop.

Operating fluids**Notes on service products**

Mercedes-AMG vehicles: be sure to observe the notes in the Supplement. Otherwise, you may fail to recognise dangers.

⚠ WARNING Risk of injury from operating fluids harmful to your health

Operating fluids may be poisonous and harmful to your health.

- ▶ Observe the text on the original containers when using, storing or disposing of operating fluids.
- ▶ Always store operating fluids sealed in their original containers.
- ▶ Always keep children away from operating fluids.



ENVIRONMENTAL NOTE Environmental pollution caused by environmentally irresponsible disposal

- ▶ Dispose of operating fluids in an environmentally responsible manner.

Service products include the following:

- fuels
- exhaust gas aftertreatment additives, e.g. AdBlue®
- lubricants
- coolant
- brake fluid
- washer fluid
- climate control system refrigerant

Only use products approved by Mercedes-Benz. Damage caused by the use of products that have not been approved is not covered by the Mercedes-Benz warranty or goodwill gestures.

You can identify service products approved by Mercedes-Benz by the following inscription on the containers:

- MB-Freigabe (e.g. MB-Freigabe 229.51)
- MB-Approval (e.g. MB-Approval 229.51)

Further information on approved service products:

- in the Mercedes-Benz Specifications for Service Products at <http://bevo.mercedes-benz.com> (by entering the designation)
- in the Mercedes-Benz Specifications for Service Products in the Mercedes-Benz BeVo app (by entering the designation)
- at a qualified specialist workshop



WARNING - Risk of fire or explosion caused by fuel

Fuels are highly inflammable.

- ▶ You must avoid fire, naked flames, creating sparks and smoking.
- ▶ Before refuelling, switch off the engine and auxiliary heating if your vehicle is equipped with auxiliary heating.



WARNING Risk of injury from fuel

Fuels are poisonous and harmful to your health

- ▶ Do not swallow fuel or let it come into contact with skin, eyes or clothing.
- ▶ Do not inhale fuel vapour.
- ▶ Keep children away from fuel.

If you or other people come into contact with fuel, observe the following:

- ▶ Immediately rinse fuel off your skin with soap and water.
- ▶ If fuel comes into contact with your eyes, immediately rinse them thoroughly with clean water. Seek medical attention immediately.
- ▶ If you swallow fuel, seek medical attention immediately. Do not induce vomiting.
- ▶ Change immediately out of clothing that has come into contact with fuel.

Fuel

Information on fuel grades for vehicles with a petrol engine

Observe the notes on operating fluids (→ page 368).

! NOTE Damage caused by the wrong fuel

Even small amounts of the wrong fuel could result in damage to the fuel system, the engine and the emission control system.

- ▶ Only refuel using premium-grade unleaded fuel that conforms to EN 228, or an equivalent specification.

Fuel of this specification may contain up to 10 % ethanol. Your vehicle is suitable for use with E10 fuel.

Do not refuel using:

- Diesel
- E85, E100
- Petrol containing methanol (M15, M30, M85, M100)

- Petrol with additives containing metal
- If you accidentally refuel with the wrong fuel:
- ▶ Do not switch the ignition on.
 - ▶ Consult a qualified specialist workshop.

If the available fuel is not sufficiently low in sulphur, this can produce unpleasant odours.

E 200 (automatic transmission), E 250, E 400 4MATIC: observe the information on sulphur content on the instruction label in the fuel filler flap:



! **NOTE** Damage to the emission control system caused by fuel with a too high sulphur content

- ▶ Only use sulphur-free fuel (sulphur content ≤ 10 ppm).

All models: the recommended octane number for your vehicle can be found on the instruction label in the fuel filler flap (→ page 176).

E 300: only refuel using super unleaded petrol with at least 98 RON if you wish to achieve maximum engine output. Alternatively, you can also refuel using premium grade petrol with at least 95 RON.

All models: as a temporary measure, if the recommended fuel is not available, you may also use regular unleaded petrol with an octane number of at least:

- **E 180, E 250, E 300 e:** 93 RON
- **All other models:** 91 RON

This may reduce engine output and increase fuel consumption.

Never refuel using petrol with a lower RON.

Further information on fuel can be found:

- at a filling station
- at a qualified specialist workshop

Information on additives in petrol

Observe the notes on service products (→ page 368).

! **NOTE** Damage caused by non-approved additives

Even small amounts of the wrong additive may lead to malfunctions occurring.

- ▶ Only add cleaning additives recommended by Mercedes-Benz to the fuel.

Mercedes-Benz recommends that you use brand-name fuels with additives.

The fuel grade available in some countries may not be sufficient. Residue could build up in the fuel injection system as a result. In this case, in consultation with a Mercedes-Benz Service Centre, the fuel may be mixed with the cleaning additive recommended by Mercedes-Benz. Be

sure to observe the notes and mixing ratios specified on the container.

Information on fuel grades for vehicles with a diesel engine

General notes

Observe the notes on operating fluids (→ page 368).

! **WARNING** Risk of fire through fuel mixture

If you mix diesel fuel with petrol, the flash point of the fuel mixture is lower than that of pure diesel fuel.

While the engine is running, component parts in the exhaust system may overheat unnoticed.

- ▶ Never refuel using petrol.
- ▶ Never mix diesel fuel with petrol.

! **NOTE** Damage caused by the wrong fuel

Even small amounts of the wrong fuel could result in damage to the fuel system, the engine and the emission control system.

- ▶ Only refuel using diesel fuel that conforms to EN 590, or an equivalent specification.
- ▶ **Vehicles with diesel particulate filters:** in countries outside the EU, only use low-sulphur Euro diesel with a sulphur content of under 50 ppm.

Do not use the following:

- petrol
- marine diesel
- heating oil
- bio-diesel
- vegetable oil
- paraffin
- kerosene

Information on low outside temperatures

Refuel your vehicle with as much winter diesel fuel as possible at the beginning of winter.

Before changing over to winter diesel fuel, the fuel tank should be empty, if possible. When refuelling with winter diesel fuel for the first time, keep the fuel level low, for example at reserve level. The fuel tank can be filled as usual when next refuelling.

Further information on fuel can be found:

- at a filling station
- at a qualified specialist workshop

Tank content and fuel reserve

The total capacity of the fuel tank may vary, depending on the vehicle equipment.

Capacity

Model	Total capacity
E 300	66.0 l
E 400 4MATIC E 450 4MATIC	66.0 l or 80.0 l
All other models	50.0 l or 66.0 l
Model	of which reserve fuel
E 400 4MATIC E 450 4MATIC	7.0 l or 12.0 l
All other models	7.0 l

Adblue®**Notes on AdBlue®**

Observe the notes on operating fluids (→ page 368).

AdBlue® is a water-soluble fluid for the exhaust gas aftertreatment of diesel engines.

! **NOTE** Damage caused by mixing additives with AdBlue® or from diluting AdBlue®

The BlueTEC exhaust gas aftertreatment system could be destroyed by:

- Additives in AdBlue®
 - Diluting AdBlue®
- ▶ Only use AdBlue® in accordance with ISO 22241.
- ▶ Do not add additives.
- ▶ Do not dilute AdBlue®.

! **NOTE** Damage and malfunctions due to impurities in AdBlue®

Impurities in AdBlue® lead to:

- Increased emissions values
- Damage to the catalytic converter
- Engine damage
- BlueTEC exhaust gas aftertreatment malfunctions

▶ Avoid impurities in AdBlue®.

 **ENVIRONMENTAL NOTE** Contamination caused by AdBlue®

AdBlue® residues crystallise after a period of time, and contaminate the surfaces with which they come into contact.

▶ Surfaces that have come into contact with AdBlue® while refilling must be immediately rinsed with water, or AdBlue® must be removed with a damp cloth and cold water.

If AdBlue® has already crystallised, clean it with a sponge and cold water.

When you open the AdBlue® tank, small amounts of ammonia vapour may escape. Do not inhale any ammonia vapours that may be released. Only fill the AdBlue® tank in well-ventilated areas.

AdBlue® filling capacity

Total capacity of AdBlue® tank

Model	Total capacity
All models	23.5 l

Engine oil

Notes on engine oil

Observe the notes on service products (→ page 368).



! **NOTE** Engine damage caused by an incorrect oil filter, incorrect oil or additives

- ▶ Do not use engine oils or oil filters which do not correspond to the specifications explicitly prescribed for the service intervals.
- ▶ Do not alter the engine oil or oil filter in order to achieve longer change intervals than prescribed.
- ▶ Do not use additives.
- ▶ Have the engine oil renewed at regular intervals.

Mercedes-Benz recommends that you have the oil change carried out at a qualified specialist workshop.

Only Mercedes-Benz approved engine oils may be used in Mercedes-Benz engines.

Further information on engine oils and oil filters:

- in the Mercedes-Benz Specifications for Service Products at <http://bevo.mercedes-benz.com> (by entering the designation)
- at a qualified specialist workshop

Petrol engines: for certain countries, different engine oils can be used in conjunction with reduced maintenance intervals.

 Further information on different engine oils can be obtained at a qualified specialist workshop.

Quality and filling capacity of engine oil

MB-Freigabe or MB-Approval

Petrol engines	MB-Freigabe or MB-Approval
All models	229.5, 229.6

MB-Freigabe or MB-Approval

Diesel engines	MB-Freigabe or MB-Approval
E 350 d E 350 d 4MATIC	229.52
All other models	228.51, 229.31, 229.51, 229.52, 229.71

If the engine oils listed in the table are not available, you may add a maximum of 1.0 l of the following engine oils once only:

- **petrol engines:**
 - E 400 4MATIC: MB-Freigabe or MB-Approval 229.3 or ACEA A3/B4
 - all other models: MB-Freigabe or MB-Approval 229.3, 229.51, 229.52 or ACEA A3/B4
- **diesel engines:**
 - E 350 d, E 350 d 4MATIC: MB-Freigabe or MB-Approval 229.51 or ACEA C3
 - all other models: ACEA C3

The following values refer to an oil change, including the oil filter.

Replacement amount

Model	Replacement amount
E 200 d E 220 d E 220 d 4MATIC	6.3 l
E 200 4MATIC E 400 4MATIC	6.5 l
E 300 d	6.8 l
E 350 d	9.0 l
E 350 d 4MATIC	8.0 l
All other models	7.0 l

Notes on brake fluid

Observe the notes on operating fluids (→ page 368).

⚠ WARNING Risk of an accident due to vapour pockets forming in the brake system

The brake fluid constantly absorbs moisture from the air. This lowers the boiling point of the brake fluid. If the boiling point is too low, vapour pockets may form in the brake system when the brakes are applied hard.

This impairs the braking effect.

- ▶ Have the brake fluid renewed at the specified intervals.

Have the brake fluid regularly changed at a qualified specialist workshop.

Only use brake fluid approved by Mercedes-Benz according to MB-Freigabe or MB-Approval 331.0.

Further information on brake fluid:

- in the Mercedes-Benz Specifications for Operating Fluids at <http://bevo.mercedes-benz.com>
- at a qualified specialist workshop

Coolant

Notes on coolant

Observe the notes on service products (→ page 368).

⚠ WARNING Risk of fire- and injury from antifreeze

If antifreeze comes into contact with hot component parts in the engine compartment, it may ignite.

- ▶ Allow the engine to cool down before you top up the antifreeze.
- ▶ Make sure that no antifreeze spills out next to the filler opening.
- ▶ Thoroughly clean the antifreeze from component parts before starting the vehicle.

! NOTE Damage caused by incorrect coolant

- ▶ Only add coolant that has been premixed with the required antifreeze protection.

Further information on coolant:

- In the Mercedes-Benz Specifications for Operating Fluids 310.1, e.g. online at <http://bevo.mercedes-benz.com>.
- At a qualified specialist workshop.

! NOTE Overheating at high outside temperatures

If an inappropriate coolant is used, the engine cooling system is not sufficiently protected against overheating and corrosion at high outside temperatures.

- ▶ Always use coolant approved by Mercedes-Benz.
- ▶ Observe the instructions in the Mercedes-Benz Specifications for Operating Fluids 310.1.

Have the coolant regularly replaced at a qualified specialist workshop.

The proportion of corrosion inhibitor/antifreeze concentrate in the engine cooling system should be:

- a minimum of 50% (antifreeze protection down to approximately -37 °C).
- a maximum of 55% (antifreeze protection down to -45 °C).

Notes on windscreen washer fluid

Observe the notes on operating fluids (→ page 368).

⚠ WARNING - Risk of fire and injury due to windscreen washer concentrate

Windscreen washer concentrate is highly flammable. It could ignite if it comes into contact with hot engine component parts or the exhaust system.

- ▶ Make sure that no windscreen washer concentrate spills out next to the filler opening.

! **NOTE** Damage to the exterior lighting due to unsuitable windscreen washer fluid

Unsuitable windscreen washer fluids may damage the plastic surface of the exterior lighting.

- ▶ Only use windscreen washer fluids which are also suitable for use on plastic surfaces, e.g. MB SummerFit or MB WinterFit.

! **NOTE** Blocked spray nozzles caused by mixing windscreen washer fluids

- ▶ Do not mix MB SummerFit and MB WinterFit with other windscreen washer fluids.

Do not use distilled or de-ionised water as the fill level sensor may be triggered erroneously.

Recommended windscreen washer fluid:

- Above freezing point: e.g. MB SummerFit
- Below freezing point: e.g. MB WinterFit

For the correct mixing ratio refer to the information on the antifreeze container.

Mix the washer fluid with the windscreen washer fluid all year round.

Vehicle data

Vehicle dimensions

The heights specified may vary as a result of the:

- tyres
- load
- condition of the suspension
- optional equipment

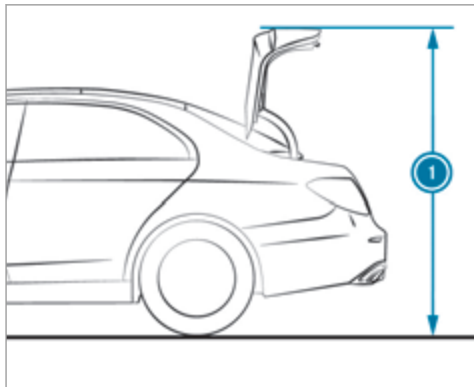

Height when opened

Model	1 Height when opened
E 200 4MATIC E 220 d 4MATIC	1845 mm
E 250 E 350 d	1839 mm
E 300	1826 mm
E 300 d	1840 mm
E 350 d 4MATIC	1846 mm
All other models	1833 mm

Vehicle dimensions

All models	
Vehicle length	4923 mm
Vehicle width including outside mirrors	2065 mm

All models

Vehicle width excluding outside mirrors	1852 mm
Wheelbase	2939 mm
Model	Vehicle height
E 200 4MATIC E 220 d 4MATIC	1480 mm
E 250 E 350 d	1474 mm
E 300	1460 mm
E 300 d	1475 mm
E 350 d 4MATIC	1481 mm
E 400 4MATIC	1467 mm
All other models	1468 mm

Weights and loads

Please note that for the specified vehicle data:

- items of optional equipment increase the unladen weight and reduce the maximum payload.
- vehicle-specific weight information can be found on the vehicle identification plate .

Roof load

All models

Maximum roof load	100 kg
-------------------	--------

Trailer hitch

General notes on the trailer hitch

Not all models can be used to tow a trailer (→ page 244).

Modifications to the engine cooling system may be necessary, depending on the vehicle model. The retrofitting of a trailer hitch is only permissible if a towing capacity is specified in your vehicle documents.

Further information can be obtained at a qualified specialist workshop.

Mounting dimensions

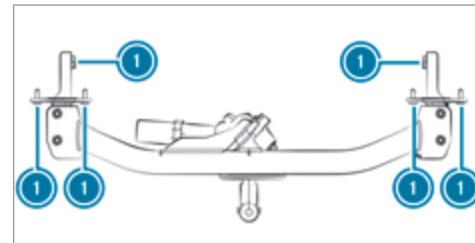
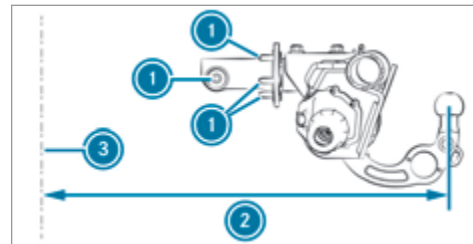

- ① Fastening point
- ② Overhang dimension
- ③ Rear axle centre line

The overhang dimension and fastening points are valid for a trailer hitch installed at the factory.

Model	2 Overhang dimension
All models	1243 mm

Permissible towing capacity

The tongue weight is not included in the towing capacity.

Permissible towing capacity, braked (at a minimum start-off gradeability of 8%)

Model	Manual transmission	Automatic transmission
E 180	–	1900 kg
E 200	1500 kg	1900 kg

Model	Manual transmission	Automatic transmission
E 250	–	2000 kg
All other models	–	2100 kg

Permissible towing capacity, braked (at a minimum start-off gradeability of 12%)

Model	Manual transmission	Automatic transmission
E 180	–	1900 kg
E 200	1500 kg	1900 kg
E 250	–	2000 kg
All other models	–	2100 kg

Permissible towing capacity, unbraked

Model	Permissible towing capacity, unbraked
All models	750 kg

Maximum tongue weight

! **NOTE** Damage caused by the trailer coming loose

If the tongue weight used is too low, the trailer may come loose.

- ▶ The tongue weight must not be below 50 kg.
- ▶ Use a tongue weight that is as close as possible to the maximum permissible tongue weight.

Tongue weight

Model	Maximum tongue weight
All models	84 kg

Permissible rear axle load during trailer operation

Axle load

Model	Axle load
E 180	1335 kg
E 200, manual transmission	1340 kg
E 200, automatic transmission	1345 kg
E 250 E 200 4MATIC	
E 200 d E 220 d	1375 kg
E 220 d 4MATIC	1365 kg
E 300 E 300 d	1370 kg

Model	Axle load
E 350 d E 400 4MATIC	1400 kg
E 350 d 4MATIC	1385 kg

Display messages

Introduction

Notes on display messages

Display messages appear on the multifunction display.



Display messages with graphic symbols are simplified in the Owner's Manual and may differ from the symbols on the multifunction display. The multifunction display shows high-priority display messages in red. Certain display messages are accompanied by a warning tone.

Please respond in accordance with the display messages and follow the additional notes in this Owner's Manual.

For some display messages, a symbol is also shown:

-  Further information

-  Hide display message

You can select the desired symbol by swiping left or right on the left-hand touch control. Press the  symbol to show further information on the multifunction display. Press the  symbol to hide the display message.

You can hide low-priority display messages by pressing the  button or the left-hand touch control. The display messages are then stored in the message memory.

Rectify the cause of a display message as quickly as possible.

High-priority display messages cannot be hidden. The multifunction display shows these display messages continuously until the cause of the message has been rectified.

Calling up stored display messages

On-board computer:

 Service  1 message

If there are no display messages, **No messages** appears on the multifunction display.

▶ Scroll through the display messages by swiping upwards or downwards on the left-hand touch control.

▶ **To exit the message memory:** press the  button.

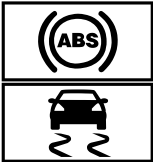

Safety systems

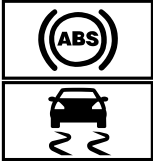

Display messages	Possible causes/consequences and ► Solutions
 <p data-bbox="53 456 359 515">inoperative See Owner's Manual</p>	<p data-bbox="466 236 1923 384">* ABS and ESP® are malfunctioning. Other driving and driving safety systems may also be malfunctioning. The brake system continues to operate normally. The braking distance may increase in an emergency braking situation.</p> <div data-bbox="492 410 1923 717" style="border: 1px solid gray; padding: 5px;"> <p data-bbox="513 420 1351 453">▲ WARNING Risk of skidding if ABS and ESP® are malfunctioning</p> <p data-bbox="513 474 1847 536">If ABS and ESP® are malfunctioning, the wheels could lock when braking and ESP® cannot carry out vehicle stabilisation.</p> <p data-bbox="513 552 1800 614">The steering capability and braking characteristics are thus severely impaired. The braking distance may increase in an emergency braking situation. In addition, other driving safety systems are switched off.</p> <ul style="list-style-type: none"> <li data-bbox="513 629 778 660">► Drive on carefully. <li data-bbox="513 676 1500 707">► Have ABS and ESP® checked immediately at a qualified specialist workshop. </div> <ul style="list-style-type: none"> <li data-bbox="492 738 758 769">► Drive on carefully. <li data-bbox="492 785 1181 816">► Consult a qualified specialist workshop immediately.

Display messages	Possible causes/consequences and ► Solutions
 <p data-bbox="118 408 433 464">currently unavailable See Owner's Manual</p>	<p data-bbox="527 184 1085 215">* ABS and ESP® are temporarily unavailable.</p> <p data-bbox="553 228 1620 260">Other driving systems and driving safety systems may also be temporarily unavailable.</p> <p data-bbox="553 273 1984 332">The brake system continues to operate normally. The braking distance may increase in an emergency braking situation.</p> <div data-bbox="553 360 1984 668" style="background-color: #f0f0f0; padding: 10px;"> <p data-bbox="578 370 1416 405">▲ WARNING Risk of skidding if ABS and ESP® are malfunctioning</p> <p data-bbox="574 422 1913 487">If ABS and ESP® are malfunctioning, the wheels could lock when braking and ESP® cannot carry out vehicle stabilisation.</p> <p data-bbox="574 501 1868 566">The steering capability and braking characteristics are thus severely impaired. The braking distance may increase in an emergency braking situation. In addition, other driving safety systems are switched off.</p> <ul style="list-style-type: none"> <li data-bbox="574 578 844 609">► Drive on carefully. <li data-bbox="574 622 1565 653">► Have ABS and ESP® checked immediately at a qualified specialist workshop. </div> <ul style="list-style-type: none"> <li data-bbox="553 687 1919 718">► Drive carefully on a suitable stretch of road, making slight steering movements at a speed above 30 km/h. <li data-bbox="553 732 1968 763">► If the display message does not disappear, consult a qualified specialist workshop immediately. Drive carefully.

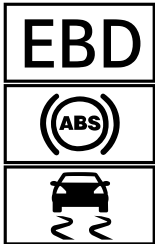
Display messages	Possible causes/consequences and ► Solutions
 <p data-bbox="53 298 369 360">currently unavailable See Owner's Manual</p>	<p data-bbox="466 184 1344 260">* ESP® is temporarily unavailable. Other driving and driving safety systems may also be malfunctioning.</p> <div data-bbox="492 282 1923 339"><p data-bbox="513 293 1222 329">▲ WARNING Risk of skidding if ESP® is malfunctioning</p></div> <p data-bbox="506 350 1882 412">If ESP® is malfunctioning, ESP® cannot carry out vehicle stabilisation. In addition, other driving safety systems are switched off.</p> <ul data-bbox="506 425 1232 505" style="list-style-type: none"><li data-bbox="506 425 778 456">▶ Drive on carefully.<li data-bbox="506 467 1232 505">▶ Have ESP® checked at a qualified specialist workshop. <p data-bbox="486 536 1907 611">▶ Carefully drive on a suitable stretch of road, making slight steering movements at a speed above 30 km/h. ▶ If the display message does not disappear, consult a qualified specialist workshop immediately. Drive carefully.</p>

Display messages	Possible causes/consequences and ► Solutions
 <p data-bbox="118 301 425 360">inoperative See Owner's Manual</p>	<p data-bbox="527 184 846 215">* ESP® is malfunctioning.</p> <p data-bbox="553 228 1406 260">Other driving and driving safety systems may also be malfunctioning.</p> <p data-bbox="553 273 1984 332">The brake system continues to operate normally. The braking distance may increase in an emergency braking situation.</p> <div data-bbox="553 360 1984 415"><p data-bbox="580 370 1283 405">▲ WARNING Risk of skidding if ESP® is malfunctioning</p></div> <p data-bbox="574 425 1943 487">If ESP® is malfunctioning, ESP® cannot carry out vehicle stabilisation. In addition, other driving safety systems are switched off.</p> <ul data-bbox="574 501 1295 578" style="list-style-type: none"><li data-bbox="574 501 840 532">► Drive on carefully.<li data-bbox="574 545 1295 578">► Have ESP® checked at a qualified specialist workshop. <ul data-bbox="553 612 1248 687" style="list-style-type: none"><li data-bbox="553 612 819 643">► Drive on carefully.<li data-bbox="553 656 1248 687">► Consult a qualified specialist workshop immediately.

Display messages	Possible causes/consequences and ► Solutions
 <p data-bbox="53 511 359 570">inoperative See Owner's Manual</p>	<p data-bbox="466 184 1344 260">* EBD, ABS and ESP[®] are malfunctioning. Other driving and driving safety systems may also be malfunctioning.</p> <div data-bbox="492 282 1923 339" style="background-color: #e0e0e0; padding: 5px;"> <p data-bbox="513 293 1422 329">⚠ WARNING Risk of skidding if EBD, ABS and ESP[®] are malfunctioning</p> </div> <p data-bbox="506 350 1892 412">If EBD, ABS and ESP[®] are malfunctioning, the wheels can lock when braking and ESP[®] cannot carry out vehicle stabilisation.</p> <p data-bbox="506 425 1806 487">The steering capability and braking characteristics are thus severely impaired. The braking distance may increase in an emergency braking situation. In addition, other driving safety systems are switched off.</p> <ul data-bbox="506 501 1539 573" style="list-style-type: none"> ▶ Drive on carefully. ▶ Have the brake system checked immediately at a qualified specialist workshop. <ul data-bbox="486 609 1185 681" style="list-style-type: none"> ▶ Drive on carefully. ▶ Consult a qualified specialist workshop immediately.
 <p data-bbox="53 816 376 878">Turn on the ignition to release the parking brake</p>	<p data-bbox="466 702 1569 774">* The red  indicator lamp is lit. You have attempted to release the electric parking brake with the ignition switched off.</p> <ul data-bbox="486 785 813 816" style="list-style-type: none"> ▶ Switch the ignition on.

Display messages	Possible causes/consequences and ► Solutions
 <p data-bbox="118 298 396 329">Release parking brake</p>	<p data-bbox="527 182 1007 213">* The red  indicator lamp flashes.</p> <p data-bbox="553 225 1273 256">The electric parking brake is applied while you are driving:</p> <ul data-bbox="560 270 1555 342" style="list-style-type: none"><li data-bbox="560 270 1555 301">• A condition for automatic release of the electric parking brake is not fulfilled .<li data-bbox="560 311 1494 342">• You are performing emergency braking using the electric parking brake . <p data-bbox="553 363 1698 394">► Check that the conditions for automatic release of the electric parking brake are fulfilled.</p> <p data-bbox="553 405 1146 436">► Release the electric parking brake manually.</p>

Display messages



Parking brake See Owner's Manual

Possible causes/consequences and ► Solutions



* The yellow  indicator lamp is lit. The electric parking brake is malfunctioning.

To apply:

- Switch off the ignition and switch it back on.
- Apply the electric parking brake manually .

If it is not possible to apply the electric parking brake:

- Consult a qualified specialist workshop.
- Where necessary, also safeguard the parked vehicle against rolling away.

The yellow  indicator lamp and the red  indicator lamp are lit. The electric parking brake is malfunctioning.

To release:



- Switch off the ignition and switch it back on.
- Release the electric parking brake manually .

or



- Release the electric parking brake automatically .

If it is still not possible to release the electric parking brake:

- Do not continue driving under any circumstances. Consult a qualified specialist workshop.



The yellow  indicator lamp is lit and the red  indicator lamp is flashing. The electric parking brake is malfunctioning.

The electric parking brake could not be applied or released.

Display messages	Possible causes/consequences and ► Solutions
	<ul style="list-style-type: none">► Switch off the ignition and switch it back on. <p>To apply:</p> <ul style="list-style-type: none">► Release and then apply the electric parking brake manually . <p>To release:</p> <ul style="list-style-type: none">► Apply and then release the electric parking brake manually. <p>If it is not possible to apply the electric parking brake or the red  indicator lamp continues to flash:</p> <ul style="list-style-type: none">► Do not continue driving under any circumstances. Consult a qualified specialist workshop.► Where necessary, also safeguard the parked vehicle against rolling away. <p>The yellow  indicator lamp is lit and the red  indicator lamp flashes for approximately ten seconds after the electric parking brake has been applied or released. It then remains lit or goes out. The electric parking brake is malfunctioning.</p> <p>If the battery charge level is too low:</p> <ul style="list-style-type: none">► Charge the battery. <p>To apply:</p> <ul style="list-style-type: none">► Switch off the ignition. The electric parking brake is applied automatically.



Display messages	Possible causes/consequences and ► Solutions
	<p>If the electric parking brake should not be applied, e.g. when washing the vehicle in an automatic car wash or when having the vehicle towed, leave the ignition switched on. Do not do this when having the vehicle towed with the rear axle raised.</p> <p>If the electric parking brake is not applied automatically:</p> <ul style="list-style-type: none">► Switch off the ignition and switch it back on.► Release and then apply the electric parking brake manually . <p>If it is still not possible to apply the electric parking brake:</p> <ul style="list-style-type: none">► Consult a qualified specialist workshop.► Where necessary, also safeguard the parked vehicle against rolling away. <p>To release:</p> <ul style="list-style-type: none">► If the conditions for automatic release are fulfilled and the electric parking brake is not released automatically, release the electric parking brake manually . <p>If it is still not possible to release the electric parking brake:</p> <ul style="list-style-type: none">► Do not continue driving under any circumstances. Consult a qualified specialist workshop.





Display messages	Possible causes/consequences and ► Solutions
<p>Brake immediately</p>	<p>* Vehicles with manual transmissions: a malfunction has occurred while the HOLD function was activated. A tone may also sound at regular intervals. If you attempt to lock the vehicle, the tone becomes louder. You cannot start the engine.</p> <p>► Immediately depress the brake pedal firmly until the display message disappears. You can restart the engine.</p>
<p></p> <p>Check brake fluid level</p>	<p>* There is insufficient brake fluid in the brake fluid reservoir.</p> <p>⚠ WARNING Risk of an accident due to low brake fluid level</p> <p>If the brake fluid level is too low, the braking effect and the braking characteristics may be impaired.</p> <p>► Pull over and stop the vehicle safely as soon as possible, paying attention to road and traffic conditions. Do not continue driving under any circumstances.</p> <p>► Consult a qualified specialist workshop. Do not top up the brake fluid.</p> <p>► Pull over and stop the vehicle safely as soon as possible, paying attention to road and traffic conditions. Do not continue driving under any circumstances.</p> <p>► Consult a qualified specialist workshop. Do not top up the brake fluid.</p>

Display messages	Possible causes/consequences and ► Solutions
 <p data-bbox="57 298 335 329">Check brake pad wear</p>	<p data-bbox="461 182 1038 213">* The brake pads have reached the wear limit.</p> <ul style="list-style-type: none"> <li data-bbox="486 223 1024 254">► Consult a qualified specialist workshop.
 <p data-bbox="57 458 196 490">Inoperative</p>	<p data-bbox="461 348 1596 379">* At least one of the main functions of the Mercedes me connect system is malfunctioning.</p> <ul style="list-style-type: none"> <li data-bbox="486 389 1024 420">► Consult a qualified specialist workshop.
<p data-bbox="57 513 349 576">Radar sensors dirty See Owner's Manual</p>	<p data-bbox="461 508 1238 539">* The radar sensor system is malfunctioning. Possible causes:</p> <ul style="list-style-type: none"> <li data-bbox="496 550 799 581">• soiling of the sensors <li data-bbox="496 591 660 622">• heavy rain <li data-bbox="496 632 1324 664">• extended country driving without other traffic, e.g. in the desert <p data-bbox="486 684 1647 715">Driving systems and driving safety systems may be malfunctioning or temporarily unavailable.</p> <p data-bbox="486 726 1917 757">Once the cause of the problem is no longer present, driving systems and driving safety systems are available again.</p> <p data-bbox="486 767 1024 798">If the display message does not disappear:</p> <ul style="list-style-type: none"> <li data-bbox="486 809 1821 840">► Pull over and stop the vehicle safely as soon as possible, paying attention to road and traffic conditions. <li data-bbox="486 850 758 881">► Clean all sensors . <li data-bbox="486 891 768 923">► Restart the engine.

Display messages	Possible causes/consequences and ► Solutions
	<p>* The radar sensor system is malfunctioning. Possible causes:</p> <ul style="list-style-type: none"> • soiling of the sensors • heavy rain • extended country driving without moving traffic, e.g. in the desert <p>Driving systems and driving safety systems may be malfunctioning or temporarily unavailable. Once the cause of the problem is no longer present, driving systems and driving safety systems are available again. If the display message does not disappear:</p> <ul style="list-style-type: none"> ► Pull over and stop the vehicle safely as soon as possible, paying attention to road and traffic conditions. ► Clean all sensors . ► Restart the engine.
<p>Active Brake Assist Functions currently limited See Owner's Manual</p>	<p>* Vehicles with the Driving Assistance Package: Active Brake Assist with cross-traffic function, Evasive Steering Assist or PRE-SAFE® PLUS are temporarily unavailable or only partially available. Vehicles without the Driving Assistance package: Active Brake Assist is temporarily unavailable. The ambient conditions are outside the system borders .</p> <ul style="list-style-type: none"> ► Drive on. As soon as the ambient conditions are within the system borders, the system will become available again. ► If the display message does not disappear, stop the vehicle while paying attention to road and traffic conditions and restart the engine.

Display messages	Possible causes/consequences and ► Solutions
Active Brake Assist Functions limited See Owner's Manual	<ul style="list-style-type: none">* Vehicles with Driving Assistance Package: Active Brake Assist with cross-traffic function, Evasive Steering Assist or PRE-SAFE® PLUS is malfunctioning. Vehicles without Driving Assistance Package: Active Brake Assist is malfunctioning. ► Consult a qualified specialist workshop.
PRE-SAFE inoperative See Owner's Manual	<ul style="list-style-type: none">* PRE-SAFE® functions are malfunctioning. ► Consult a qualified specialist workshop.
PRE-SAFE impulse side inoperative See Owner's Manual	<ul style="list-style-type: none">* PRE-SAFE® Impulse Side is malfunctioning or inoperative after having already been triggered. ► Consult a qualified specialist workshop.



Display messages	Possible causes/consequences and ► Solutions
 <p>Restraint sys. malfunction Consult workshop</p>	<p>* The restraint system is faulty .</p> <p>▲ WARNING Risk of injury or fatal injury due to a malfunction in the restraint system</p> <p>If the restraint system is malfunctioning, restraint system components may be triggered unintentionally or might not be triggered at all in the event of an accident. This may affect the seat belt tensioner or airbag, for example.</p> <p>► Have the restraint system checked and repaired immediately at a qualified specialist workshop.</p> <p>Detection of a restraint system malfunction:</p> <ul style="list-style-type: none">• the  restraint system warning lamp does not light up when the ignition is switched on.• the  restraint system warning lamp lights up continuously or repeatedly during a journey. <p>► Consult a qualified specialist workshop immediately.</p>



Display messages	Possible causes/consequences and ► Solutions
 <p data-bbox="53 298 394 363">Front left malfunction Consult workshop (example)</p>	<p data-bbox="466 182 1167 213">* The corresponding restraint system is malfunctioning .</p> <div data-bbox="492 236 1923 288" style="background-color: #e0e0e0; padding: 5px;"> <p data-bbox="513 246 1596 277">▲ WARNING Risk of injury or fatal injury due to a malfunction in the restraint system</p> </div> <p data-bbox="506 298 1855 391">If the restraint system is malfunctioning, restraint system components may be triggered unintentionally or might not be triggered at all in the event of an accident. This may affect the seat belt tensioner or airbag, for example.</p> <p data-bbox="506 407 1739 438">► Have the restraint system checked and repaired immediately at a qualified specialist workshop.</p> <p data-bbox="486 469 1038 500">Detection of a restraint system malfunction:</p> <ul data-bbox="496 515 1698 588" style="list-style-type: none"> • the  restraint system warning lamp does not light up when the ignition is switched on. • the  restraint system warning lamp lights up continuously or repeatedly during a journey. <p data-bbox="486 609 1187 640">► Consult a qualified specialist workshop immediately.</p>
 <p data-bbox="53 774 369 868">Left windowbag malfunction Consult workshop (example)</p>	<p data-bbox="466 658 1105 689">* The corresponding windowbag is malfunctioning .</p> <div data-bbox="492 712 1923 764" style="background-color: #e0e0e0; padding: 5px;"> <p data-bbox="513 723 1575 754">▲ WARNING Risk of injury or fatal injury due to a malfunction in the window airbag</p> </div> <p data-bbox="506 774 1896 837">The window airbag might be triggered unintentionally or might not be triggered at all in the event of an accident with high deceleration.</p> <p data-bbox="506 847 1719 878">► Have the window airbag checked and repaired immediately at a qualified specialist workshop.</p> <p data-bbox="486 909 1187 940">► Consult a qualified specialist workshop immediately.</p>

Display messages	Possible causes/consequences and ► Solutions
<p>Front-passenger airbag disabled See Owner's Manual</p>	<p>* The front passenger airbag is disabled, even though an adult or a person with a build corresponding to that of an adult is seated on the front passenger seat. If additional forces are applied to the seat, the weight the system detects may be too low.</p> <p>▲ WARNING - Risk of injury or even fatal injury when the front passenger airbag is disabled</p> <p>If the front passenger airbag is disabled, It will not be deployed in the event of an accident and cannot perform its intended protective function.</p> <p>A person in the front passenger seat could then, for example, come into contact with the vehicle interior, especially if the person is sitting too close to the dashboard.</p> <p>► Be aware of the status of the front passenger airbag both before and during the journey.</p> <ul style="list-style-type: none">► Pull over and stop the vehicle safely as soon as possible, paying attention to road and traffic conditions.► Check the status of the automatic front passenger airbag shutoff .► If necessary, consult a qualified specialist workshop immediately.

Display messages	Possible causes/consequences and ► Solutions
<p>Front-passenger airbag enabled See Owner's Manual</p>	<p>* The front passenger airbag is enabled while the vehicle is in motion:</p> <ul style="list-style-type: none">• even when a child, a small adult or an object weighing less than the system weight threshold is located on the front passenger seat• even when the front passenger seat is not occupied <p>The system may detect objects or forces that are adding to the weight applied to the seat.</p> <p>▲ WARNING Risk of injury or fatal injury when using a child restraint system while the front passenger airbag is enabled</p> <p>If you secure a child in a child restraint system on the front passenger seat and the front passenger airbag is enabled, the front passenger airbag can deploy in the event of an accident.</p> <p>The child could be struck by the airbag.</p> <p>► Ensure, both before and during the journey, that the status of the front passenger airbag is correct.</p> <p>NEVER use a rearward facing child restraint on a seat protected by an ACTIVE FRONT AIRBAG in front of it; DEATH or SERIOUS INJURY to the CHILD can occur.</p> <ul style="list-style-type: none">► Pull over and stop the vehicle safely as soon as possible, paying attention to road and traffic conditions.► Check the status of the automatic front passenger airbag shutoff .► If necessary, consult a qualified specialist workshop immediately.

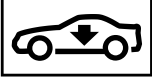
Driving systems

Display messages	Possible causes/consequences and ► Solutions
 <p data-bbox="118 350 459 409">ATTENTION ASSIST: Take a break!</p>	<ul style="list-style-type: none"> <li data-bbox="527 236 1835 295">* ATTENTION ASSIST has detected fatigue or an increasing lack of concentration on the part of the driver (→ page 237). <li data-bbox="547 310 923 339">► If necessary, take a break.
 <p data-bbox="118 547 459 606">ATTENTION ASSIST inoperative</p>	<ul style="list-style-type: none"> <li data-bbox="527 433 1017 462">* ATTENTION ASSIST is malfunctioning. <li data-bbox="547 477 1087 506">► Consult a qualified specialist workshop.
 <p data-bbox="118 743 288 772">Vehicle rising</p>	<ul style="list-style-type: none"> <li data-bbox="527 629 1234 658">* Your vehicle is adjusting to the level you have selected.
 <p data-bbox="118 904 235 931">Lowering</p>	<ul style="list-style-type: none"> <li data-bbox="527 790 1234 819">* Your vehicle is adjusting to the level you have selected.



Display messages	Possible causes/consequences and ► Solutions
 <p data-bbox="53 298 374 329">Vehicle rising Please wait</p>	<ul style="list-style-type: none"> * The vehicle level is too low. The vehicle will be raised to the selected vehicle level. <ul style="list-style-type: none"> ► Wait until the display message disappears before pulling away.
 <p data-bbox="53 461 357 519">Stop vehicle Vehicle too low</p>	<ul style="list-style-type: none"> * You have pulled away despite the vehicle level being too low. <ul style="list-style-type: none"> ► Pull over and stop the vehicle safely as soon as possible, paying attention to road and traffic conditions. The vehicle will be raised to the selected vehicle level. ► Wait until the display message disappears before pulling away. <p>If the display message does not disappear and a warning tone also sounds, AIR BODY CONTROL/DYNAMIC BODY CONTROL is malfunctioning:</p> <ul style="list-style-type: none"> ► Do not drive faster than 80 km/h and consult a qualified specialist workshop immediately. <div style="border: 1px solid black; padding: 5px; margin-top: 10px;"> <p>! NOTE The tyres of the front axle or the front wings could be damaged by large steering movements</p> <ul style="list-style-type: none"> ► Avoid large steering movements while driving and listen for scraping sounds. ► If you hear scraping sounds, pull over and stop the vehicle safely, paying attention to road and traffic conditions, and set a higher vehicle level if possible. </div> <ul style="list-style-type: none"> ► Set a higher vehicle level . Depending on the malfunction, the vehicle is raised.

Display messages	Possible causes/consequences and ► Solutions
 <p data-bbox="118 277 392 339">Fault Drive at max. 80 km/h</p>	<ul style="list-style-type: none"> <li data-bbox="527 184 1823 215">* The AIR BODY CONTROL function is restricted. The vehicle's handling characteristics may be affected. <ul style="list-style-type: none"> <li data-bbox="555 225 1590 256">► Drive in a manner appropriate for the current level, but do not exceed 80 km/h. <li data-bbox="555 267 1087 298">► Consult a qualified specialist workshop. <li data-bbox="527 302 1802 333">DYNAMIC BODY CONTROL is malfunctioning. The vehicle's handling characteristics may be affected. <ul style="list-style-type: none"> <li data-bbox="555 343 1169 375">► Do not drive at speeds greater than 80 km/h. <li data-bbox="555 385 1087 416">► Consult a qualified specialist workshop.
<p data-bbox="118 443 453 536">Active Lane Keeping Assist currently unavailable See Owner's Manual</p>	<ul style="list-style-type: none"> <li data-bbox="527 437 1230 468">* Active Lane Keeping Assist is temporarily unavailable. <p data-bbox="555 478 1414 509">The ambient conditions are outside the system borders (→ page 241).</p> <p data-bbox="555 520 1680 551">Vehicles with Active Steering Assist: the camera view may be limited by the windscreen.</p> <ul style="list-style-type: none"> <li data-bbox="555 561 1905 623">► Drive on. As soon as the ambient conditions are within the system borders, the system will become available again. <p data-bbox="555 660 1557 692">If the display message does not disappear on vehicles with Active Steering Assist:</p> <ul style="list-style-type: none"> <li data-bbox="555 702 1884 733">► Pull over and stop the vehicle safely as soon as possible, paying attention to road and traffic conditions. <li data-bbox="555 743 862 774">► Clean the windscreen.
<p data-bbox="118 799 453 861">Active Lane Keeping Assist inoperative</p>	<ul style="list-style-type: none"> <li data-bbox="527 789 1107 820">* Active Lane Keeping Assist is malfunctioning. <ul style="list-style-type: none"> <li data-bbox="555 830 1087 861">► Consult a qualified specialist workshop.

Display messages	Possible causes/consequences and ► Solutions
<p>Active Lane Keeping Assist Camera view restricted See Owner's Manual</p>	<p>* Vehicles without Active Steering Assist: the camera view is restricted.</p> <p>Possible causes:</p> <ul style="list-style-type: none"> • dirt on the windscreen in the camera's field of vision • heavy rain, snow or fog <p>Driving systems and driving safety systems may be malfunctioning or temporarily unavailable.</p> <p>Once the cause of the problem is no longer present, driving systems and driving safety systems are available again.</p> <p>If the display message does not disappear:</p> <ul style="list-style-type: none"> ► Pull over and stop the vehicle safely as soon as possible, paying attention to road and traffic conditions. ► Clean the windscreen.
<p>Blind Spot Assist currently unavailable See Owner's Manual</p>	<p>* Blind Spot Assist is temporarily unavailable.</p> <p>The system borders have been reached (→ page 239).</p> <ul style="list-style-type: none"> ► Drive on. Once the cause of the problem is no longer present, the system will be available again. <p>or</p> <ul style="list-style-type: none"> ► If the display message does not disappear, stop the vehicle while paying attention to road and traffic conditions and restart the engine. ► If necessary, clean the rear bumper. If the bumper is extremely dirty, the sensors in the bumper may be malfunctioning.

Display messages	Possible causes/consequences and ► Solutions
Active Blind Spot Assist currently unavailable See Owner's Manual	<ul style="list-style-type: none"> * Active Blind Spot Assist is temporarily unavailable. The system borders have been reached (→ page 239). <ul style="list-style-type: none"> ► Drive on. Once the cause of the problem is no longer present, the system will be available again. ► If the display message does not disappear, stop the vehicle while paying attention to road and traffic conditions and restart the engine.
Blind Spot Assist not available when towing a trailer See Owner's Manual	<ul style="list-style-type: none"> * When you establish the electrical connection to the trailer, Blind Spot Assist is unavailable. <ul style="list-style-type: none"> ► Press the left-hand side of touch control and acknowledge the display message.
Active Blind Spot Assist not available when towing a trailer See Owner's Manual	<ul style="list-style-type: none"> * When you establish the electrical connection to the trailer, Active Blind Spot Assist is unavailable. <ul style="list-style-type: none"> ► Press the left-hand side of touch control and acknowledge the display message.
Blind Spot Assist inoperative	<ul style="list-style-type: none"> * Blind Spot Assist is malfunctioning. <ul style="list-style-type: none"> ► Consult a qualified specialist workshop.
Active Blind Spot Assist inoperative	<ul style="list-style-type: none"> * Active Blind Spot Assist is malfunctioning. <ul style="list-style-type: none"> ► Consult a qualified specialist workshop.

Display messages	Possible causes/consequences and ► Solutions
<p>Active Parking Assist and PARKTRONIC inoperative See Owner's Manual</p>	<ul style="list-style-type: none"> * Active Parking Assist and Parking Assist PARKTRONIC are malfunctioning. <ul style="list-style-type: none"> ► Stop the vehicle, paying attention to road and traffic conditions, and restart the engine. ► If the display message continues to be displayed, consult a qualified specialist workshop.
<div style="border: 2px solid black; padding: 10px; text-align: center; width: 60px; margin: 0 auto;"> <p>HOLD</p> </div> <p>Off</p>	<ul style="list-style-type: none"> * The HOLD function is deactivated because the vehicle is skidding or a condition for activation is not met. <ul style="list-style-type: none"> ► Reactivate the HOLD function later or check the activation conditions for the HOLD function .
<p>Active Distance Assist available again</p>	<ul style="list-style-type: none"> * Active Distance Assist DISTRONIC is operational again and can be activated (→ page 207).
<p>Active Distance Assist currently unavailable See Owner's Manual</p>	<ul style="list-style-type: none"> * Active Distance Assist DISTRONIC is temporarily unavailable. The ambient conditions are outside the system borders (→ page 205). <ul style="list-style-type: none"> ► Drive on. As soon as the ambient conditions are within the system borders, the system will become available again.
<p>Active Distance Assist inoperative</p>	<ul style="list-style-type: none"> * Active Distance Assist DISTRONIC is malfunctioning. Other driving and driving safety systems may also be malfunctioning. <ul style="list-style-type: none"> ► Consult a qualified specialist workshop.



Display messages	Possible causes/consequences and ► Solutions
 <p data-bbox="118 298 466 391">Active Steering Assist currently unavailable See Owner's Manual</p>	<ul style="list-style-type: none"> <li data-bbox="527 184 1420 256">* Active Steering Assist is temporarily unavailable. The ambient conditions are outside the system borders (→ page 210). <li data-bbox="547 267 1911 339">► Drive on. As soon as the ambient conditions are within the system borders, the system will become available again. <li data-bbox="547 344 1406 376">► If necessary, clean the windscreen in the camera's field of vision.
 <p data-bbox="118 526 466 588">Active Steering Assist inoperative</p>	<ul style="list-style-type: none"> <li data-bbox="527 412 1712 443">* Active Steering Assist is malfunctioning. Active Distance Assist DISTRONIC remains available. <li data-bbox="547 453 1089 484">► Consult a qualified specialist workshop.
<p data-bbox="118 614 308 645">Limiter passive</p>	<ul style="list-style-type: none"> <li data-bbox="527 603 1978 666">* If you depress the accelerator pedal beyond the pressure point (kickdown), the limiter is switched to passive mode (→ page 203).
 <p data-bbox="343 738 455 769">--- km/h</p>	<ul style="list-style-type: none"> <li data-bbox="527 681 1518 712">* Cruise control cannot be activated as not all activation conditions are fulfilled. <li data-bbox="547 723 1252 754">► Observe the activation conditions for cruise control .
<p data-bbox="118 821 339 852">Cruise control off</p>	<ul style="list-style-type: none"> <li data-bbox="527 811 1835 883">* Cruise control has been deactivated. If there is an additional warning tone, cruise control has been switched off automatically (→ page 201).
<p data-bbox="118 909 441 940">Cruise control inoperative</p>	<ul style="list-style-type: none"> <li data-bbox="527 899 1089 971">* Cruise control is malfunctioning. ► Consult a qualified specialist workshop.

Display messages	Possible causes/consequences and ► Solutions
Cruise control and Limiter inoperative	<ul style="list-style-type: none"> * Cruise control and the limiter are malfunctioning. <ul style="list-style-type: none"> ► Consult a qualified specialist workshop.
Limiter inoperative	<ul style="list-style-type: none"> * The limiter is malfunctioning. <ul style="list-style-type: none"> ► Consult a qualified specialist workshop.
<div style="border: 2px solid black; padding: 5px; display: inline-block; margin-right: 10px;">LIM</div> --- km/h	<ul style="list-style-type: none"> * The limiter cannot be activated as not all activation conditions have been fulfilled. <ul style="list-style-type: none"> ► Observe the activation conditions of the limiter .
Speed limit (winter tyres) XXX km/h	<ul style="list-style-type: none"> * You have reached the stored maximum speed for winter tyres. It is not possible to exceed this speed.
<div style="border: 2px solid black; padding: 5px; display: inline-block; margin-right: 10px;">120km/h!</div> Maximum speed exceeded	<ul style="list-style-type: none"> * The maximum permissible speed has been exceeded (only for certain countries). <ul style="list-style-type: none"> ► Drive more slowly.

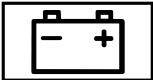
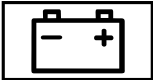
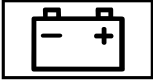

Engine



Display messages	Possible causes/consequences and ► Solutions
<p>Top up coolant See Owner's Manual</p>	<p>* The coolant level is too low.</p> <div data-bbox="553 288 1984 394" style="border: 1px solid black; padding: 5px;"> <p>! NOTE Engine damage due to insufficient coolant</p> <p>► Avoid long journeys with insufficient coolant.</p> </div> <p>► Add coolant .</p>
<div data-bbox="128 464 324 567" style="border: 1px solid black; padding: 5px; text-align: center;">  </div> <p>Coolant Stop vehicle Switch engine off</p>	<p>* The coolant is too hot.</p> <p>► Stop the vehicle immediately, paying attention to road and traffic conditions, and switch off the engine.</p> <div data-bbox="553 567 1984 791" style="border: 1px solid black; padding: 5px;"> <p>! WARNING Danger of burns when opening the bonnet</p> <p>If you open the engine bonnet when the engine has overheated or during a fire in the engine compartment, you could come into contact with hot gases or other escaping operating fluids.</p> <p>► Before opening the bonnet, allow the engine to cool down.</p> <p>► In the event of a fire in the engine compartment, keep the engine bonnet closed and call the fire service.</p> </div> <p>► Wait until the engine has cooled down.</p> <p>► Make sure that the air supply to the radiator is not obstructed.</p> <p>► Avoiding high loads on the engine, drive on to the nearest qualified specialist workshop. In doing so, ensure that the coolant temperature display remains below 120 °C.</p>



Display messages	Possible causes/consequences and ► Solutions
 <p data-bbox="53 298 314 325">See Owner's Manual</p>	<p data-bbox="466 180 901 211">* The battery is not being charged.</p> <div data-bbox="492 236 1923 387" style="border: 1px solid gray; padding: 5px;"> <p data-bbox="513 246 1228 277">! NOTE Possible engine damage if you continue driving</p> <ul style="list-style-type: none"> <li data-bbox="513 298 1173 329">▶ Do not continue driving under any circumstances. <li data-bbox="513 339 1050 370">▶ Consult a qualified specialist workshop. </div> <ul style="list-style-type: none"> <li data-bbox="486 408 1815 439">▶ Stop the vehicle immediately, paying attention to road and traffic conditions, and switch off the engine. <li data-bbox="486 449 1024 480">▶ Consult a qualified specialist workshop.
 <p data-bbox="53 612 376 671">Start engine See Owner's Manual</p>	<p data-bbox="466 495 1181 526">* The engine is off and the battery charge level is too low.</p> <ul style="list-style-type: none"> <li data-bbox="486 536 1201 567">▶ Switch off electrical consumers that are not required. <li data-bbox="486 578 1447 646">▶ Leave the engine running for a few minutes, or drive for a longer distance. The battery charges.
	<p data-bbox="466 692 1079 723">* The quiescent current in the vehicle is too high.</p> <ul style="list-style-type: none"> <li data-bbox="486 733 1024 764">▶ Consult a qualified specialist workshop.





Display messages	Possible causes/consequences and ► Solutions
 <p>48 V battery See Owner's Manual</p>	<ul style="list-style-type: none"> * The 48 V system is malfunctioning. <ul style="list-style-type: none"> ► Convenience functions may be restricted. ► Consult a qualified specialist workshop.
 <p>Stop vehicle See Owner's Manual</p>	<ul style="list-style-type: none"> * The battery is no longer being charged and the battery charge level is too low. <div style="border: 1px solid black; padding: 5px; margin: 10px 0;"> <p>! NOTE Possible engine damage if you continue driving</p> <ul style="list-style-type: none"> ► Do not continue driving under any circumstances. ► Consult a qualified specialist workshop. </div> <ul style="list-style-type: none"> ► Pull over and stop the vehicle safely as soon as possible, paying attention to road and traffic conditions. Do not continue driving under any circumstances. ► Switch off the engine. ► Consult a qualified specialist workshop.





Display messages	Possible causes/consequences and ► Solutions
 <p data-bbox="53 298 386 363">Please wait Charging high-voltage battery</p>	<p data-bbox="466 184 1872 246">* The 48 V battery is discharged. You have switched on the ignition while the 12 V battery is being charged with a suitable charger or while another vehicle is providing starting assistance.</p> <p data-bbox="486 260 1909 322">The discharged 48 V battery is charged automatically via the voltage converter. After a few minutes, the Motor can be started again display message is shown on the multifunction display.</p> <ul style="list-style-type: none"> <li data-bbox="486 335 737 366">► Start the engine. <li data-bbox="486 380 1872 442">► Drive the vehicle for a while to charge the 12 V battery and the 48 V battery after disconnecting the charger from the vehicle. <p data-bbox="486 476 1575 507">If the Motor can be started again display message does not appear after a few minutes:</p> <ul style="list-style-type: none"> <li data-bbox="486 521 887 552">► Try to start the engine again. <li data-bbox="486 565 1371 596">► If the engine does not start, consult a qualified specialist workshop.
<p data-bbox="53 618 355 680">Cannot start engine See Owner's Manual</p>	<p data-bbox="466 608 1504 639">* The charge level of the 48 V battery is too low. You can no longer start the engine.</p> <ul style="list-style-type: none"> <li data-bbox="486 652 1193 683">► Switch off electrical consumers that are not required. <li data-bbox="486 697 1913 788">► Connect a suitable charger approved by Mercedes-Benz with sufficient charge output to the jump-start connection point of the 12 V battery . The 48 V battery is charged via the voltage converter in the vehicle.
<p data-bbox="53 815 390 846">Motor can be started again</p>	<p data-bbox="466 804 1418 836">* The 48 V battery has been charged automatically via the voltage converter.</p> <ul style="list-style-type: none"> <li data-bbox="486 849 1733 880">► Start the engine and drive the vehicle for a while to charge the 12 V battery and the 48 V battery.

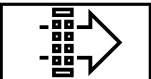

Display messages	Possible causes/consequences and ► Solutions
 <p data-bbox="118 298 445 363">Stop vehicle Leave engine running</p>	<p data-bbox="527 182 983 213">* The battery charge level is too low.</p> <ul style="list-style-type: none"> <li data-bbox="553 225 1974 288">► Pull over and stop the vehicle safely as soon as possible, paying attention to road and traffic conditions. Do not continue driving under any circumstances. <li data-bbox="553 301 915 332">► Leave the engine running. <li data-bbox="553 346 1371 377">► Wait until the display message disappears before pulling away.
 <p data-bbox="118 505 421 570">Check eng. oil lev. when next refuelling</p>	<p data-bbox="527 389 1228 420">* The engine oil level has dropped to the minimum level.</p> <div data-bbox="553 443 1984 550" style="border: 1px solid black; padding: 5px;"> <p data-bbox="574 453 1459 484">! NOTE Engine damage caused by driving with insufficient engine oil</p> <ul style="list-style-type: none"> <li data-bbox="574 505 1201 536">► Avoid long journeys with insufficient engine oil. </div> <ul style="list-style-type: none"> <li data-bbox="553 570 1181 601">► Check the engine oil level when next refuelling. <p data-bbox="553 622 993 653">Top up the engine oil (→ page 311).</p> <p data-bbox="553 667 977 698">Notes on engine oil (→ page 373).</p>

Display messages	Possible causes/consequences and ► Solutions
 <p data-bbox="53 298 376 363">Engine oil level Stop vehicle Switch engine off</p>	<p data-bbox="466 184 1005 256">* Display message only for certain engines: The engine oil level is too low.</p> <div data-bbox="492 277 1917 386" style="border: 1px solid black; padding: 5px;"><p data-bbox="513 291 1394 322">! NOTE Engine damage caused by driving with insufficient engine oil</p><p data-bbox="513 339 1140 370">► Avoid long journeys with insufficient engine oil.</p></div> <ul data-bbox="486 407 1913 557" style="list-style-type: none"><li data-bbox="486 407 1913 469">► Pull over and stop the vehicle safely as soon as possible, paying attention to road and traffic conditions. Do not continue driving under any circumstances.<li data-bbox="486 479 805 510">► Switch off the engine.<li data-bbox="486 521 860 552">► Check the engine oil level. <p data-bbox="486 578 927 609">Top up the engine oil (→ page 311).</p> <p data-bbox="486 619 911 650">Notes on engine oil (→ page 373).</p>
 <p data-bbox="53 785 376 847">Engine oil level Reduce oil level</p>	<p data-bbox="466 671 1005 743">* Display message only for certain engines: The engine oil level is too high.</p> <div data-bbox="492 764 1917 873" style="border: 1px solid black; padding: 5px;"><p data-bbox="513 778 1340 809">! NOTE Engine damage caused by driving with excess engine oil</p><p data-bbox="513 826 1085 857">► Avoid long journeys with excess engine oil.</p></div> <ul data-bbox="486 888 1643 919" style="list-style-type: none"><li data-bbox="486 888 1643 919">► Consult a qualified specialist workshop immediately and have the engine oil siphoned off.

Display messages	Possible causes/consequences and ► Solutions
 <p data-bbox="118 298 453 363">Add 1 litre engine oil when next refuelling</p>	<p data-bbox="527 182 1228 256">* Display message only for certain engines: The engine oil level has dropped to the minimum level.</p> <div data-bbox="553 280 1984 384" style="border: 1px solid black; padding: 5px;"> <p data-bbox="574 291 1459 322">! NOTE Engine damage caused by driving with insufficient engine oil</p> <p data-bbox="574 339 1201 370">► Avoid long journeys with insufficient engine oil.</p> </div> <p data-bbox="547 407 1181 438">► Check the engine oil level when next refuelling.</p> <p data-bbox="547 458 989 490">Top up the engine oil (→ page 311).</p> <p data-bbox="547 500 977 531">Notes on engine oil (→ page 373).</p>
 <p data-bbox="118 666 421 728">Engine oil pressure Stop Switch off engine</p>	<p data-bbox="527 552 1071 624">* Display message only for certain engines: The engine oil pressure is too low.</p> <div data-bbox="553 645 1984 749" style="border: 1px solid black; padding: 5px;"> <p data-bbox="574 655 1575 686">! NOTE Engine damage caused by driving with insufficient engine oil pressure</p> <p data-bbox="574 707 1320 738">► Avoid long journeys with insufficient engine oil pressure.</p> </div> <p data-bbox="547 774 1978 837">► Pull over and stop the vehicle safely as soon as possible, paying attention to road and traffic conditions. Do not continue driving under any circumstances.</p> <p data-bbox="547 852 1089 883">► Consult a qualified specialist workshop.</p>



Display messages	Possible causes/consequences and ► Solutions
 <p data-bbox="53 298 376 360">Engine oil level cannot be measured</p>	<p data-bbox="461 184 1635 256">* The electrical connection to the oil level sensor is interrupted or the oil level sensor is faulty. The engine oil level has dropped to the minimum level.</p> <p data-bbox="486 267 1026 298">► Consult a qualified specialist workshop.</p>
 <p data-bbox="53 492 294 523">Clean the fuel filter</p>	<p data-bbox="461 378 1753 409">* Vehicles with diesel engines: the fuel filter is dirty or the water in the fuel filter must be drained off.</p> <p data-bbox="486 419 1026 450">► Consult a qualified specialist workshop.</p>
 <p data-bbox="53 651 294 682">Replace air cleaner</p>	<p data-bbox="461 537 1500 568">* Vehicles with diesel engines: the engine air filter is dirty and must be replaced.</p> <p data-bbox="486 579 1026 610">► Consult a qualified specialist workshop.</p>
 <p data-bbox="53 811 273 842">Reserve fuel level</p>	<p data-bbox="461 697 1128 728">* The fuel supply has dropped into the reserve range.</p> <p data-bbox="486 738 621 769">► Refuel.</p>

Display messages	Possible causes/consequences and ► Solutions
	<ul style="list-style-type: none"> * The fan motor is defective. <ul style="list-style-type: none"> ► Avoiding high loads on the engine, drive on to the nearest qualified specialist workshop. In doing so, ensure that the coolant temperature display remains below 120 °C.
 <p data-bbox="118 461 441 519">Refill AdBlue See Owner's Manual</p>	<ul style="list-style-type: none"> * The AdBlue® level has fallen below the reserve range. <ul style="list-style-type: none"> ► Refill AdBlue® immediately .
 <p data-bbox="118 654 416 712">Refill AdBlue No start in XXX km</p>	<ul style="list-style-type: none"> * The AdBlue® level is only sufficient for the displayed distance. <ul style="list-style-type: none"> ► Refill AdBlue® immediately . ⓘ The message disappears after driving at a speed above 15 km/h for approximately one minute.
 <p data-bbox="118 848 453 906">Refill AdBlue Eng. start not possible</p>	<ul style="list-style-type: none"> * The AdBlue® tank is empty. You can no longer start the engine. <ul style="list-style-type: none"> ► Top up at least 4.5 l of AdBlue® . ► Switch the ignition on. You can restart the engine after approximately one minute.

Display messages	Possible causes/consequences and ► Solutions
 <p data-bbox="53 298 396 360">Check AdBlue See Owner's Manual</p>	<ul style="list-style-type: none"> * The AdBlue® system is malfunctioning. <ul style="list-style-type: none"> ► Consult a qualified specialist workshop.
 <p data-bbox="53 495 367 557">Eng. start not possible in XXX km</p>	<ul style="list-style-type: none"> * The AdBlue® system is malfunctioning. <ul style="list-style-type: none"> ► Consult a qualified specialist workshop immediately.
 <p data-bbox="53 688 335 718">Eng. start not possible</p>	<ul style="list-style-type: none"> * The AdBlue® system is malfunctioning. you can no longer start the engine. <ul style="list-style-type: none"> ► Consult a qualified specialist workshop immediately.

Tyres

Display messages	Possible causes/consequences and ► Solutions
<p>Tyre pressure Check tyres</p>	<p>* The tyre pressure loss warning system has detected a significant loss in pressure.</p> <div style="background-color: #f0f0f0; padding: 5px; border: 1px solid #ccc;"> <p>▲ WARNING Risk of an accident due to insufficient tyre pressure</p> <p>Tyres with insufficient tyre pressure pose the following risks:</p> <ul style="list-style-type: none"> • The tyres may burst, especially as the load and vehicle speed increase. • The tyres may wear excessively and/or unevenly, which may greatly impair tyre traction. • - The driving characteristics, steering and braking may be greatly impaired. <p>You could then lose control of the vehicle.</p> <ul style="list-style-type: none"> ► Observe the recommended tyre pressures. ► Adjust the tyre pressure if necessary. </div> <ul style="list-style-type: none"> ► Stop the vehicle, paying attention to road and traffic conditions. ► Check the tyre pressure and the tyres. ► When the tyre pressure is correct, restart the tyre pressure loss warning system .
<p>Check tyre pressures then restart Run Flat Indicator</p>	<p>* The tyre pressure loss warning system generated a display message and has not been restarted since.</p> <ul style="list-style-type: none"> ► When the tyre pressure is correct, restart the tyre pressure loss warning system .
<p>Run Flat Indicator inoperative</p>	<p>* The tyre pressure loss warning system is malfunctioning.</p> <ul style="list-style-type: none"> ► Consult a qualified specialist workshop.



Display messages	Possible causes/consequences and ► Solutions
 <p data-bbox="57 298 314 329">Rectify tyre pressure</p>	<p data-bbox="466 184 1892 246">* The tyre pressure is too low in at least one of the tyres, or the tyre pressure difference between the wheels is too great.</p> <ul style="list-style-type: none"> <li data-bbox="486 256 1148 288">► Check the tyre pressure and add air, if necessary. <li data-bbox="486 298 1516 329">► When the tyre pressure is correct, restart the tyre pressure monitoring system .
 <p data-bbox="57 464 220 495">Check tyre(s)</p>	<p data-bbox="466 350 1688 381">* The tyre pressure in one or more tyres has dropped significantly. The wheel position is displayed.</p> <div data-bbox="494 401 1921 449" style="background-color: #e0e0e0; padding: 5px;"> <p data-bbox="515 412 1349 443">▲ WARNING Risk of an accident due to insufficient tyre pressure</p> </div> <p data-bbox="511 464 1263 495">Tyres with insufficient tyre pressure pose the following risks:</p> <ul style="list-style-type: none"> <li data-bbox="519 505 1434 536">• The tyres may burst, especially as the load and vehicle speed increase. <li data-bbox="519 547 1647 578">• The tyres may wear excessively and/or unevenly, which may greatly impair tyre traction. <li data-bbox="519 588 1479 619">• - The driving characteristics, steering and braking may be greatly impaired. <p data-bbox="511 644 1030 675">You could then lose control of the vehicle.</p> <ul style="list-style-type: none"> <li data-bbox="511 685 1087 716">► Observe the recommended tyre pressures. <li data-bbox="511 727 1017 758">► Adjust the tyre pressure if necessary. <ul style="list-style-type: none"> <li data-bbox="486 795 1324 826">► Stop the vehicle, paying attention to road and traffic conditions. <li data-bbox="486 837 1009 868">► Check the tyre pressure and the tyres.



Display messages	Possible causes/consequences and ► Solutions
 <p data-bbox="118 298 363 329">Warning tyre defect</p>	<p data-bbox="527 182 1719 213">* The tyre pressure in one or more tyres has dropped suddenly. The wheel position is displayed.</p> <div data-bbox="553 236 1984 565" style="border: 1px solid #ccc; padding: 10px;"> <p data-bbox="574 246 1351 277">▲ WARNING Risk of an accident from driving with a flat tyre</p> <p data-bbox="574 296 1150 327">Flat tyres are dangerous in the following ways:</p> <ul data-bbox="584 339 1545 412" style="list-style-type: none"> <li data-bbox="584 339 1116 370">• The tyres can overheat and cause a fire. <li data-bbox="584 381 1545 412">• - The driving characteristics, steering and braking may be greatly impaired. <p data-bbox="574 436 1095 467">You could then lose control of the vehicle.</p> <ul data-bbox="574 479 1013 552" style="list-style-type: none"> <li data-bbox="574 479 966 510">► Do not drive with a flat tyre. <li data-bbox="574 521 1013 552">► Observe the notes on flat tyres. </div> <p data-bbox="553 586 966 617">Notes on flat tyres (→ page 324).</p> <ul data-bbox="553 629 1391 702" style="list-style-type: none"> <li data-bbox="553 629 1391 660">► Stop the vehicle, paying attention to road and traffic conditions. <li data-bbox="553 671 803 702">► Check the tyres.
<p data-bbox="118 726 421 793">Tyre press. monitor currently unavailable</p>	<p data-bbox="527 721 1968 783">* No signals can be received from the tyre pressure sensors due to strong radio signal source interference. The tyre pressure monitoring system is temporarily unavailable.</p> <ul data-bbox="553 795 1841 857" style="list-style-type: none"> <li data-bbox="553 795 1841 857">► Drive on. The tyre pressure monitoring system restarts automatically as soon as the cause has been rectified.

Display messages	Possible causes/consequences and ► Solutions
 <p>Wheel sensor(s) missing</p>	<ul style="list-style-type: none"> * There is no signal from the tyre pressure sensor of one or more wheels. The pressure of the affected tyre is not displayed. <ul style="list-style-type: none"> ► Have the faulty tyre pressure sensor replaced at a qualified specialist workshop.
<p>Tyre press. monitor inoperative No wheel sensors</p>	<ul style="list-style-type: none"> * The wheels fitted do not have suitable tyre pressure sensors. The tyre pressure monitoring system is deactivated. <ul style="list-style-type: none"> ► Fit wheels with suitable tyre pressure sensors.
<p>Tyre press. monitor inoperative</p>	<ul style="list-style-type: none"> * The tyre pressure monitoring system is faulty. <div style="border: 1px solid black; padding: 10px; margin: 10px 0;"> <p>⚠ WARNING There is a risk of an accident if the tyre pressure monitoring system is malfunctioning</p> <p>If the tyre pressure monitoring system is malfunctioning, it is not able to issue a warning if there is pressure loss in one or more of the tyres.</p> <p>Tyres with insufficient tyre pressure may, for example, affect the vehicle's handling characteristics, steering and braking. -</p> <ul style="list-style-type: none"> ► Have the tyre pressure monitoring system checked at a qualified specialist workshop. </div> <ul style="list-style-type: none"> ► Consult a qualified specialist workshop.
<p>Tyre(s) overheated</p>	<ul style="list-style-type: none"> * At least one tyre is overheating. The affected tyres are displayed in red. At temperatures close to the limit value, the tyres are displayed in yellow. <ul style="list-style-type: none"> ► Drive more slowly.

Display messages	Possible causes/consequences and ► Solutions
Tyre(s) overheated Reduce speed	<p>* At least one tyre is overheating.</p> <div style="border: 1px solid black; padding: 5px; margin: 5px 0;"> <p>▲ WARNING Risk of an accident from driving with overheated tyres</p> <p>Overheated tyres may burst, particularly at high speeds.</p> <p>► Reduce speed so that the tyres cool down.</p> </div> <p>► Reduce speed so that the tyres cool down.</p>

Key

Display messages	Possible causes/consequences and ► Solutions
 <p>Replace key</p>	<p>* The key needs to be replaced.</p> <p>► Consult a qualified specialist workshop.</p>
 <p>Replace key See Owner's Manual</p>	<p>* Vehicles with a digital vehicle key: only a few or no authorisations remain for starting the engine.</p> <ul style="list-style-type: none"> ► Make sure that the internet connection is not limited by certain mobile phone settings. ► Open the Mercedes me connect web app http://www.mercedes.me. and call up the digital vehicle key service. ► Deactivate the service first and then activate it again. ► If the display message still appears, contact the Mercedes-Benz Customer Assistance Center (CAC).

Display messages	Possible causes/consequences and ► Solutions
 <p>Change key batteries</p>	<ul style="list-style-type: none"> * The key battery is discharged. <ul style="list-style-type: none"> ► Replace the battery .
 <p>Key not detected (white display message)</p>	<ul style="list-style-type: none"> * The key is currently undetected. <ul style="list-style-type: none"> ► Change the location of the key in the vehicle. ► If the key is still not recognised, start the engine with the key in the stowage compartment .
 <p>Key not detected (red display message)</p>	<ul style="list-style-type: none"> * The key cannot be detected and may no longer be in the vehicle. The key is no longer in the vehicle and you switch off the engine: <ul style="list-style-type: none"> • you can no longer start the engine. • you cannot centrally lock the vehicle. <ul style="list-style-type: none"> ► Ensure that the key is in the vehicle. <p>If the key detection function has a malfunction due to a strong radio signal source:</p> <ul style="list-style-type: none"> ► Pull over and stop the vehicle safely as soon as possible, paying attention to road and traffic conditions. ► Place the key in the stowage compartment for starting the engine with the key .

Display messages	Possible causes/consequences and ► Solutions
 <p data-bbox="118 298 461 391">Place the key in the marked space See Owner's Manual</p>	<ul style="list-style-type: none"> * The key detection function is malfunctioning. <ul style="list-style-type: none"> ► Change the location of the key in the vehicle. ► Start the vehicle with the key in the stowage compartment .

Vehicle

Display messages	Possible causes/consequences and ► Solutions
 <p data-bbox="118 682 461 713">Trailer coupling extending...</p>	<ul style="list-style-type: none"> * Retract or extend the ball neck. Do not attempt to speed up, slow down or initiate the retracting or extending process using your hand, foot or other aids. During the retracting or extending process, do not couple a trailer. When the ball neck has reached an operational position, the display message disappears.

Display messages



Check trailer hitch lock

Possible causes/consequences and ► Solutions

* The trailer hitch is not operational when you are driving with a trailer.

- Stop the vehicle immediately, paying attention to road and traffic conditions, and switch off the engine.
- Uncouple the trailer and safeguard it against rolling away.
- Initiate a new swivelling procedure .
- If the ball neck is extended, press and hold the button on the boot lid until the ball neck engages beneath the bumper.
- When the display message disappears, couple up the trailer and drive on.

⚠ WARNING Risk of an accident if the ball neck is not locked

If the ball neck is not in the locked position, the trailer may come loose.

- Pull over and stop the vehicle safely as soon as possible, paying attention to road and traffic conditions. Do not continue driving under any circumstances.
- Uncouple the trailer and secure it against rolling away.
- Initiate a new swivelling procedure and do not re-couple the trailer until the display message disappears.

If the display message does not disappear, the trailer hitch is defective and the ball neck is not locked.

- Do not couple up the trailer. Drive on without the trailer. Note the reduced ground clearance due to the unlocked ball neck.
- Consult a qualified specialist workshop.



The trailer hitch is not operational when the vehicle is at a standstill.

Display messages	Possible causes/consequences and ► Solutions
	<ul style="list-style-type: none"> ► Uncouple the coupled trailer and safeguard it against rolling away. ► Initiate a new swivelling procedure . ► If the ball neck is retracted: press and hold the button on the boot lid until the ball neck engages vertically in the locked position and then engages beneath the bumper. ► If the ball neck is extended: press and hold the button on the boot lid until the ball neck engages beneath the bumper. <p>If the display message does not disappear, the trailer hitch is defective and the ball neck is not locked.</p> <ul style="list-style-type: none"> ► Do not couple up the trailer. Drive on without the trailer. Note the reduced ground clearance due to the unlocked ball neck. ► Consult a qualified specialist workshop.
Apply brake to deselect Park (P) position	<p>* You have attempted to shift the transmission out of position P and into another transmission position.</p> <ul style="list-style-type: none"> ► Depress the brake pedal.
To shift out of P or N, depress brake and start engine	<p>* You have attempted to shift the transmission out of position P or N into another transmission position.</p> <ul style="list-style-type: none"> ► Depress the brake pedal. ► Start the engine.
Risk of vehicle rolling Driver door open and transmission not in P	<p>* The driver's door is not fully closed and the transmission is in position R, N or D.</p> <ul style="list-style-type: none"> ► Shift the transmission to position P when you park the vehicle.



Display messages	Possible causes/consequences and ► Solutions
<p>N permanently active Risk of vehicle rolling</p>	<ul style="list-style-type: none"> * While the vehicle is rolling or while you are driving, the transmission has been shifted to position N. <ul style="list-style-type: none"> ► Depress the brake pedal to stop and, when the vehicle is stationary, shift the transmission to position P. ► To continue your journey, shift the transmission to position D or R.
<p>Only select Park (P) when vehicle is stationary</p>	<ul style="list-style-type: none"> * The transmission can be shifted to position P only when the vehicle is stationary.
<p>Without changing gear, consult workshop</p>	<ul style="list-style-type: none"> * The transmission is malfunctioning. The transmission position can no longer be shifted. <ul style="list-style-type: none"> ► When the transmission is in position D, consult a qualified specialist workshop and do not shift the transmission position. ► For all other transmission positions, park the vehicle safely. ► Consult a qualified specialist workshop.
<div data-bbox="63 614 261 718" data-label="Image"> </div> <p>Vehicle is operational Switch off the ignition before exiting</p>	<ul style="list-style-type: none"> * You are leaving the vehicle when it is in a ready-to-drive state. <ul style="list-style-type: none"> ► When you leave the vehicle, switch off the ignition and take the key with you. ► If you do not leave the vehicle, switch off the electrical consumers, e.g. the seat heater. Otherwise, the 12 V battery may discharge and it will then be possible to start the vehicle only using a donor battery (starting assistance).



Display messages	Possible causes/consequences and ► Solutions
Transmission Malfunction Stop	<ul style="list-style-type: none"> * The transmission is malfunctioning. The transmission shifts to position N automatically. <ul style="list-style-type: none"> ► Pull over and stop the vehicle safely as soon as possible, paying attention to road and traffic conditions. ► Switch the transmission to position P. ► Consult a qualified specialist workshop.
Reversing not poss. Consult workshop	<ul style="list-style-type: none"> * The transmission is malfunctioning. Reverse gear can no longer be engaged. <ul style="list-style-type: none"> ► Consult a qualified specialist workshop.
Stop vehicle Leave engine running Wait Transmission cooling	<ul style="list-style-type: none"> * The transmission is overheating. Pulling away may be temporarily impaired or not possible. <ul style="list-style-type: none"> ► Pull over and stop the vehicle safely as soon as possible, paying attention to road and traffic conditions. Do not continue driving under any circumstances. ► Leave the engine running. ► Wait until the display message disappears before pulling away.
Auxiliary battery malfunction	<ul style="list-style-type: none"> * The auxiliary battery for the transmission is no longer being charged. <ul style="list-style-type: none"> ► Consult a qualified specialist workshop. ► Until then, always manually set the transmission to position P before you switch off the engine. ► Before leaving the vehicle, apply the electric parking brake.



Display messages	Possible causes/consequences and ► Solutions
<p>Depress clutch fully to start engine</p>	<ul style="list-style-type: none"> * You have attempted to start the engine without depressing the clutch pedal. <ul style="list-style-type: none"> ► Depress the clutch pedal and then start the engine. The engine has stalled while the vehicle was pulling away, e.g. because the clutch pedal was released too quickly. ► Depress the clutch pedal again. The engine starts automatically. ► Slowly release the clutch pedal to pull away.
<p>Clutch overheated Avoid pulling away for XX:XX mins</p>	<ul style="list-style-type: none"> * The clutch is under considerable load and is overheating. Avoid frequent pulling away and driving at walking pace over longer distances. <ul style="list-style-type: none"> ► Stop the vehicle, paying attention to road and traffic conditions, and leave the engine running. The clutch is cooled more quickly when the engine is running. <p>or</p> <ul style="list-style-type: none"> ► If possible, continue driving at a steady speed and remove your foot from the clutch pedal. Do not ride the clutch. The clutch is cooled while the vehicle is in motion. When the clutch has cooled down, the display message will disappear.
<p>Air conditioning Malfunction See Owner's Manual</p>	<ul style="list-style-type: none"> * Operation of the climate control system is temporarily restricted. Airflow and fresh air supply are set to automatic mode. <ul style="list-style-type: none"> ► Have the climate control system checked at a qualified specialist workshop.



Display messages	Possible causes/consequences and ► Solutions
<p>Apply brake to select R</p>	<ul style="list-style-type: none"> * You have attempted to shift the transmission out of position D and into transmission position R. <ul style="list-style-type: none"> ► Depress the brake pedal. ► Switch the transmission to position R.
 <p>Operation only possible in transmission position N</p>	<ul style="list-style-type: none"> * You have attempted to swivel the ball neck and the transmission is not in position N. <ul style="list-style-type: none"> ► Switch the transmission to position N.
 <p>Operation only possible in transmission position P</p>	<ul style="list-style-type: none"> * You have attempted to swivel the ball neck and the transmission is in position R, N or D. <ul style="list-style-type: none"> ► Depress the brake pedal. ► Switch the transmission to position P.
 <p>Before starting the engine, turn the steering wheel.</p>	<ul style="list-style-type: none"> * Vehicles with manual transmissions: the electric steering lock was unable to unlock the steering. <ul style="list-style-type: none"> ► Switch off the ignition. ► To unlock the steering, move the steering wheel slightly to the left and right. ► Switch the ignition back on.

Display messages	Possible causes/consequences and ► Solutions
 <p>Steering malfunction See Owner's Manual</p>	<p>* Vehicles with manual transmissions: the electric steering lock is malfunctioning. The steering may be locked by the electric steering lock.</p> <p>▲ WARNING Risk of accident if steering capability is impaired</p> <p>If the steering does not function as intended, the vehicle's operating safety is jeopardised.</p> <ul style="list-style-type: none"> ► Pull over and stop the vehicle safely as soon as possible, paying attention to road and traffic conditions. Do not continue driving under any circumstances. ► Consult a qualified specialist workshop. <p>► Pull over and stop the vehicle safely as soon as possible, paying attention to road and traffic conditions. Do not continue driving under any circumstances.</p> <p>► Consult a qualified specialist workshop.</p>
<p>Let fresh air into the vehicle interior! Air conditioning malf. Visit workshop</p>	<p>* The climate control system is malfunctioning.</p> <p>▲ WARNING Risk of injury and accident due to an insufficient supply of fresh air</p> <p>If the climate control system is malfunctioning, carbon dioxide levels may increase in the passenger compartment. Breathing in carbon dioxide may cause dizziness.</p> <ul style="list-style-type: none"> ► Open the window to ensure that there is a sufficient supply of fresh air. <p>► Open the window to ensure that there is an adequate supply of fresh air.</p> <p>► Consult a qualified specialist workshop immediately.</p>



Display messages	Possible causes/consequences and ► Solutions
 <p data-bbox="118 298 451 360">Steering malfunction Drive carefully Visit workshop</p>	<ul style="list-style-type: none"> * The power assistance for the steering is malfunctioning. You may need to use more force to steer. <ul style="list-style-type: none"> ► Drive on carefully. ► Consult a qualified specialist workshop.
 <p data-bbox="118 495 441 588">Steering malfunction Stop immediately See Owner's Manual</p>	<ul style="list-style-type: none"> * The steering is malfunctioning. Steering capability is considerably impaired. <div style="background-color: #e0e0e0; padding: 5px; margin: 5px 0;"> <p>⚠ WARNING Risk of accident if steering capability is impaired</p> </div> <p>If the steering does not function as intended, the vehicle's operating safety is jeopardised.</p> <ul style="list-style-type: none"> ► Pull over and stop the vehicle safely as soon as possible, paying attention to road and traffic conditions. Do not continue driving under any circumstances. ► Consult a qualified specialist workshop. ► Pull over and stop the vehicle safely as soon as possible, paying attention to road and traffic conditions. Do not continue driving under any circumstances. ► Consult a qualified specialist workshop.

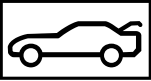



Display messages	Possible causes/consequences and ► Solutions
 <p>Steering malfunction Increased physical effort See Owner's Manual</p>	<p>* The power assistance for the steering is malfunctioning.</p> <div style="background-color: #f0f0f0; padding: 5px; border: 1px solid #ccc;"> <p>▲ WARNING Risk of an accident due to altered steering characteristics</p> <p>If the power assistance of the steering fails partially or completely, you will need to use more force to steer.</p> <ul style="list-style-type: none"> ▶ If safe steering is possible, drive on carefully. ▶ Visit or consult a qualified specialist workshop immediately. </div> <ul style="list-style-type: none"> ▶ If safe steering is possible, drive on carefully. ▶ Visit or consult a qualified specialist workshop immediately.
 <p>inoperative Battery low</p>	<p>* The on-board electrical system voltage is too low. The stationary heater has switched itself off.</p> <ul style="list-style-type: none"> ▶ Drive for an extended period until the battery has reached a sufficient charge level again.
 <p>inoperative Refuel vehicle</p>	<p>* There is too little fuel in the fuel tank. The stationary heater cannot be switched on.</p> <ul style="list-style-type: none"> ▶ Refuel the vehicle.
<p>Active bonnet malfunction See Owner's Manual</p>	<p>* The active bonnet (pedestrian protection) is malfunctioning or inoperative after having already been triggered.</p> <ul style="list-style-type: none"> ▶ Consult a qualified specialist workshop.

Display messages	Possible causes/consequences and ► Solutions
 <p data-bbox="118 298 425 360">inoperative See Owner's Man.</p>	<p data-bbox="527 182 1195 213">* The stationary heater is temporarily malfunctioning.</p> <ul style="list-style-type: none"> <li data-bbox="547 225 1964 288">► When the vehicle is on a level surface and the engine has cooled down, make up to four attempts to switch on the stationary heater, waiting several minutes between each attempt. <li data-bbox="547 301 1627 332">► If the stationary heater does not switch on, consult a qualified specialist workshop.
	<p data-bbox="527 376 799 407">* The bonnet is open.</p> <div data-bbox="553 430 1984 482" style="background-color: #e0e0e0; padding: 5px;"> <p data-bbox="574 441 1559 472">▲ WARNING Risk of accident due to driving with the engine bonnet unlocked</p> </div> <p data-bbox="568 493 1708 524">An unlocked engine bonnet may open up when the vehicle is in motion and block your view.</p> <ul style="list-style-type: none"> <li data-bbox="568 534 1187 565">► Never unlock the engine bonnet when driving. <li data-bbox="568 576 1340 607">► Before every trip, ensure that the engine bonnet is locked. <ul style="list-style-type: none"> <li data-bbox="547 638 1299 669">► Pull over and stop the vehicle safely as soon as possible. <li data-bbox="547 679 819 710">► Close the bonnet.
	<p data-bbox="513 731 870 762">* At least one door is open.</p> <ul style="list-style-type: none"> <li data-bbox="547 772 788 803">► Close all doors.

Display messages	Possible causes/consequences and ► Solutions
	<p>* The boot lid is open.</p> <p>▲ WARNING Risk of exhaust gas poisoning</p> <p>Combustion engines emit poisonous exhaust gases such as carbon monoxide. Exhaust gases can enter the vehicle interior if the boot lid is open when the engine is running, especially if the vehicle is in motion.</p> <ul style="list-style-type: none">▶ Always switch off the engine before opening the boot lid.▶ Never drive with the boot lid open. <p>► Close the boot lid.</p>
 <p>Rear left seat backrest not locked (example)</p>	<p>* The corresponding seat backrest of the rear bench seat is not engaged.</p> <p>► Fold the corresponding seat backrest back until it engages.</p>
 <p>Top up washer fluid</p>	<p>* The washer fluid level in the washer fluid reservoir has dropped below the minimum.</p> <p>► Top up the washer fluid .</p>

Lights

Display messages	Possible causes/consequences and ► Solutions
 <p>Left dipped beam (example)</p>	<ul style="list-style-type: none"> * The corresponding light source is defective. <ul style="list-style-type: none"> ► Consult a qualified specialist workshop. or ► Check whether you are permitted to replace the light source yourself . ⓘ LED light bulbs: the display message for the corresponding lamp appears only when all the light-emitting diodes in the lamp have failed.
 <p>Active Light System inoperative</p>	<ul style="list-style-type: none"> * The active headlamps are faulty. <ul style="list-style-type: none"> ► Consult a qualified specialist workshop.
 <p>Intelligent Light System inoperative</p>	<ul style="list-style-type: none"> * The Intelligent Light System is faulty. The lighting system continues to function properly without the functions of the Intelligent Light System. <ul style="list-style-type: none"> ► Consult a qualified specialist workshop.

Display messages	Possible causes/consequences and ► Solutions
 <p data-bbox="53 298 369 360">Malfunction See Owner's Manual</p>	<ul style="list-style-type: none"> <li data-bbox="461 184 850 213">* The exterior lighting is faulty. <ul style="list-style-type: none"> <li data-bbox="486 225 1024 254">► Consult a qualified specialist workshop. <li data-bbox="486 260 1167 289">Vehicles with a trailer hitch: a fuse may have blown. <li data-bbox="486 301 1821 330">► Pull over and stop the vehicle safely as soon as possible, paying attention to road and traffic conditions. <li data-bbox="486 342 1132 371">► Check the fuses and replace them if necessary .
 <p data-bbox="53 508 349 537">AUTO lights inoperative</p>	<ul style="list-style-type: none"> <li data-bbox="461 391 799 420">* The light sensor is faulty. <ul style="list-style-type: none"> <li data-bbox="486 433 1024 462">► Consult a qualified specialist workshop.
 <p data-bbox="53 669 257 698">Switch off lights</p>	<ul style="list-style-type: none"> <li data-bbox="461 552 1259 581">* You are leaving the vehicle and the lights are still switched on. <ul style="list-style-type: none"> <li data-bbox="486 593 1054 622">► Turn the light switch to the AUTO position.
 <p data-bbox="53 829 322 858">Switch on headlamps</p>	<ul style="list-style-type: none"> <li data-bbox="461 712 1095 741">* You are driving without dipped-beam headlamps. <ul style="list-style-type: none"> <li data-bbox="486 754 1156 783">► Turn the light switch to the  or AUTO position.
<p data-bbox="53 881 384 945">Adaptive Highbeam Assist Plus inoperative</p>	<ul style="list-style-type: none"> <li data-bbox="461 873 983 902">* Adaptive Highbeam Assist Plus is faulty. <ul style="list-style-type: none"> <li data-bbox="486 914 1024 943">► Consult a qualified specialist workshop.

Display messages	Possible causes/consequences and ► Solutions
<p>Adaptive Highbeam Assist Plus currently unavailable See Owner's Manual</p>	<p>* Adaptive Highbeam Assist Plus is temporarily unavailable. The system borders have been reached (→ page 134).</p> <p>► Drive on. Once the cause of the problem is no longer present, the system will be available again. The Adaptive Highbeam Assist Plus available again display message appears.</p>
<p>Adaptive Highbeam Assist Plus Camera view restricted See Owner's Manual</p>	<p>* The camera view is restricted. Possible causes:</p> <ul style="list-style-type: none"> • dirt on the windscreen in the camera's field of vision • heavy rain, snow or fog <p>Driving systems and driving safety systems may be malfunctioning or temporarily unavailable. Once the cause of the problem is no longer present, driving systems and driving safety systems will become available again.</p> <p>If the display message does not disappear:</p> <p>► Pull over and stop the vehicle safely as soon as possible, paying attention to road and traffic conditions. ► Clean the windscreen.</p>
<p>Adaptive Highbeam Assist inoperative</p>	<p>* Adaptive Highbeam Assist is malfunctioning.</p> <p>► Consult a qualified specialist workshop.</p>

Display messages	Possible causes/consequences and ► Solutions
<p>Adaptive Highbeam Assist currently unavailable See Owner's Manual</p>	<p>* Adaptive Highbeam Assist is temporarily unavailable. The system borders have been reached (→ page 132).</p> <p>► Drive on. Once the cause of the problem is no longer present, the system will be available again. The Adaptive Highbeam Assist available again display message appears.</p>
<p>Adaptive Highbeam Assist Camera view restricted See Owner's Manual</p>	<p>* The camera view is restricted. Possible causes:</p> <ul style="list-style-type: none"> • dirt on the windscreen in the camera's field of vision • heavy rain, snow or fog <p>Driving systems and driving safety systems may be malfunctioning or temporarily unavailable. Once the cause of the problem is no longer present, driving systems and driving safety systems will become available again.</p> <p>If the display message does not disappear:</p> <p>► Pull over and stop the vehicle safely as soon as possible, paying attention to road and traffic conditions.</p> <p>► Clean the windscreen.</p>

Warning and indicator lamps

Overview of warning and indicator lamps

Some systems perform a self-test when the ignition is switched on. Some warning and indicator

lamps may briefly light up or flash. This behaviour is non-critical. These warning and indicator lamps indicate a malfunction only if they light up or flash after the engine is started or during a journey.

Instrument display (standard)



Instrument display in the widescreen cockpit







Progressive setting in the widescreen cockpit



If you select the progressive display setting in vehicles with a widescreen cockpit, the positions of the indicator lamps on the instrument display change.

Warning and indicator lamps:

-  Dipped beam (→ page 127)
-  Standing lights (→ page 127)
-  Main beam (→ page 129)
-  Turn signal light (→ page 129)
-  Rear fog lights (→ page 127)



Seat belt is not fastened
(→ page 446)



Brakes (red) (→ page 440)



Brakes (yellow) (→ page 440)



ABS malfunction (→ page 440)



AIR BODY CONTROL malfunction
(→ page 447)



DYNAMIC BODY CONTROL malfunction
(→ page 447)



ESP® (→ page 440)



ESP® OFF (→ page 440)



Electric parking brake (→ page 440)



Steering assistance malfunction
(→ page 449)



Electrical fault (→ page 451)



Restraint system (→ page 440)



Engine diagnostics (→ page 451)



Fuel reserve with fuel filler flap location indicator
(→ page 451)



Coolant too hot/cold (→ page 451)



Distance warning (→ page 447)



Preglow



Tyre pressure monitoring system
(→ page 454)



Trailer hitch is not operational or is
swivelling (→ page 449)

Safety systems

Warning/indicator lamp	Possible causes/consequences and ► Solutions
 <p data-bbox="53 495 400 560">Brake system warning lamp (yellow)</p>	<p data-bbox="437 379 1324 410">The yellow brake system warning lamp is lit while the engine is running.</p> <div data-bbox="437 433 1929 625"><p data-bbox="451 443 1330 474">▲ WARNING Risk of an accident due to a brake system malfunction</p><p data-bbox="457 495 1438 526">If the brake system is malfunctioning, braking characteristics may be impaired.</p><ul data-bbox="457 536 1488 612" style="list-style-type: none"><li data-bbox="457 536 727 567">► Drive on carefully.<li data-bbox="457 578 1488 612">► Have the brake system checked immediately at a qualified specialist workshop.</div> <ul data-bbox="437 643 1712 763" style="list-style-type: none"><li data-bbox="437 643 1712 674">► Adjust your speed and continue to drive carefully, leaving a suitable distance to the vehicle in front.<li data-bbox="437 684 1398 715">► If the multifunction display shows a display message, please observe this.<li data-bbox="437 726 977 763">► Consult a qualified specialist workshop.

Warning/indicator lamp

Brake system warning lamp
(red)

Possible causes/consequences and ► Solutions

The red brake system warning lamp is lit while the engine is running.

Possible causes:

- The brake force boosting is malfunctioning and the braking characteristics may be affected.
- There is insufficient brake fluid in the brake fluid reservoir.

▲ WARNING There is a risk of an accident if brake force boosting is malfunctioning

If brake force boosting is malfunctioning, increased brake pedal force may be necessary for braking. Braking characteristics may be impaired. The braking distance may increase in an emergency braking situation.



- Pull over and stop the vehicle safely as soon as possible, paying attention to road and traffic conditions. Do not continue driving under any circumstances.
- Consult a qualified specialist workshop.

▲ WARNING Risk of an accident due to low brake fluid level

If the brake fluid level is too low, the braking effect and the braking characteristics may be impaired.

- Pull over and stop the vehicle safely as soon as possible, paying attention to road and traffic conditions. Do not continue driving under any circumstances.
- Consult a qualified specialist workshop.
Do not top up the brake fluid.

Warning/indicator lamp	Possible causes/consequences and ► Solutions
	<ul style="list-style-type: none"> ► Pull over and stop the vehicle safely as soon as possible, paying attention to road and traffic conditions. Do not continue driving under any circumstances. ► Observe the messages on the multifunction display. ► Consult a qualified specialist workshop.
<div style="border: 1px solid black; padding: 5px; display: inline-block; margin-bottom: 5px;">  </div> <p>ABS warning lamp</p>	<p>The yellow ABS warning lamp is lit while the engine is running. ABS is malfunctioning. If there is an additional acoustic warning signal, EBD is malfunctioning. Other driving systems and driving safety systems may also be faulty.</p> <div style="background-color: #f0f0f0; padding: 5px; border: 1px solid #ccc; margin: 10px 0;"> <p>▲ WARNING There is risk of skidding if EBD or ABS is malfunctioning</p> <p>If EBD or ABS is malfunctioning, the wheels could lock when braking The steering capability and braking characteristics are thus severely impaired. The braking distance may increase in an emergency braking situation. In addition, other driving safety systems are switched off.</p> <ul style="list-style-type: none"> ► Drive on carefully. ► Have the brake system checked immediately at a qualified specialist workshop. </div> <ul style="list-style-type: none"> ► Drive on carefully. ► Observe the messages in the multifunction display. ► Consult a qualified specialist workshop.

Warning/indicator lamp	Possible causes/consequences and ► Solutions
 <p>ESP® warning lamp flashes</p>	<p>The yellow ESP® warning lamp flashes while the vehicle is in motion. ESP® is intervening .</p> <ul style="list-style-type: none">► Adapt your driving style to suit the road and weather conditions.
 <p>ESP® warning lamp lights up</p>	<p>The yellow ESP® warning lamp is lit while the engine is running. ESP® is malfunctioning. Other driving and driving safety systems may also be faulty.</p> <p>⚠ WARNING Risk of skidding if ESP® is malfunctioning</p> <p>If ESP® is malfunctioning, ESP® cannot carry out vehicle stabilisation. In addition, other driving safety systems are switched off.</p> <ul style="list-style-type: none">► Drive on carefully.► Have ESP® checked at a qualified specialist workshop. <ul style="list-style-type: none">► Drive on carefully.► Observe the messages in the multifunction display.► Consult a qualified specialist workshop.

Warning/indicator lamp



ESP[®] OFF warning lamp

Possible causes/consequences and ► Solutions

The yellow ESP[®] OFF warning lamp is lit while the engine is running.
ESP[®] is deactivated.

▲ WARNING Risk of skidding when driving with ESP[®] deactivated



If ESP[®] is deactivated, ESP[®] cannot carry out vehicle stabilisation. The availability of further driving safety systems is also limited.

- ▶ Drive on carefully.
- ▶ Only deactivate ESP[®] for as long as the situation requires.

If ESP[®] cannot be activated, ESP[®] is malfunctioning.

- ▶ Have ESP[®] checked immediately at a qualified specialist workshop.

- ▶ Observe the notes on deactivating ESP[®] .

Warning/indicator lamp	Possible causes/consequences and ► Solutions
 <p data-bbox="118 298 461 363">Red indicator lamp, electric parking brake applied</p>  <p data-bbox="118 481 461 570">Yellow electric parking brake indicator lamp is malfunctioning</p>	<p data-bbox="500 184 1970 239">The red electric parking brake indicator lamp flashes or is lit. The yellow indicator lamp is also lit if the electric parking brake malfunctions.</p> <ul data-bbox="500 256 1181 288" style="list-style-type: none"><li data-bbox="500 256 1181 288">► Observe the messages in the multifunction display.

Warning/indicator lamp	Possible causes/consequences and ► Solutions
 <p data-bbox="57 298 369 360">Restraint system warning lamp</p>	<p data-bbox="441 182 1324 256">The red restraint system warning lamp is lit while the engine is running. The restraint system is malfunctioning.</p> <div data-bbox="441 277 1923 459"><p data-bbox="455 288 1545 322">▲ WARNING Risk of injury or fatal injury due to a malfunction in the restraint system</p><p data-bbox="461 339 1902 405">If the restraint system is malfunctioning, restraint system components may be triggered unintentionally or might not be triggered at all in the event of an accident. This may affect the seat belt tensioner or airbag, for example.</p><p data-bbox="461 415 1688 449">► Have the restraint system checked and repaired immediately at a qualified specialist workshop.</p></div> <ul data-bbox="441 480 1136 594" style="list-style-type: none"><li data-bbox="441 480 707 514">► Drive on carefully.<li data-bbox="441 525 1116 559">► Observe the messages in the multifunction display.<li data-bbox="441 569 1136 594">► Consult a qualified specialist workshop immediately.

Seat belt

Warning/indicator lamp	Possible causes/consequences and ► Solutions
 <p data-bbox="57 886 343 948">Seat belt warning lamp lights up</p>	<p data-bbox="441 770 1275 845">The red seat belt warning lamp lights up after the engine is started. In addition, an acoustic warning tone may sound.</p> <p data-bbox="441 855 1586 889">The seat belt warning lamp reminds the driver and front passenger to fasten their seat belts.</p> <ul data-bbox="441 900 758 928" style="list-style-type: none"><li data-bbox="441 900 758 928">► Fasten your seat belt . <p data-bbox="441 948 1647 983">If you have placed objects on the front passenger seat, the seat belt warning lamp may remain lit.</p>

Warning/indicator lamp	Possible causes/consequences and ► Solutions
 <p data-bbox="118 298 408 360">Seat belt warning lamp flashes</p>	<p data-bbox="502 182 1504 213">The red seat belt warning lamp flashes and an intermittent warning tone sounds.</p> <p data-bbox="502 223 1631 254">The driver or front passenger has not fastened their seat belt while the vehicle is in motion.</p> <ul data-bbox="502 265 1177 376" style="list-style-type: none"><li data-bbox="502 265 823 296">► Fasten your seat belt .<li data-bbox="502 301 1079 332">There are objects on the front passenger seat.<li data-bbox="502 342 1177 376">► Remove the objects from the front passenger seat.

Driving systems

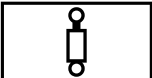
Warning/indicator lamp	Possible causes/consequences and ► Solutions
 <p data-bbox="118 662 439 693">Suspension warning lamp</p>	<p data-bbox="502 545 1146 577">The yellow AIR BODY CONTROL warning lamp is on.</p> <p data-bbox="502 587 1222 618">The yellow DYNAMIC BODY CONTROL warning lamp is on.</p> <p data-bbox="502 628 866 659">AIR BODY CONTROL is faulty.</p> <p data-bbox="502 670 1111 701">There is a fault in the DYNAMIC BODY CONTROL.</p> <ul data-bbox="502 711 1187 749" style="list-style-type: none"><li data-bbox="502 711 1187 749">► Observe the messages on the multifunction display.

Warning/indicator lamp



Distance warning warning lamp

Possible causes/consequences and ► Solutions

The red distance warning lamp lights up while the vehicle is in motion.

The distance to the vehicle in front is too small for the speed selected.

If there is an additional warning tone, you are approaching an obstacle at too high a speed.

► Be prepared to brake immediately.

► Increase the distance.

Active Brake Assist .

Vehicle

Warning/indicator lamp	Possible causes/consequences and ► Solutions
 <p>Trailer hitch warning lamp</p>	<p>The red trailer hitch warning lamp is on. The trailer hitch is not operational or swivels.</p> <p>⚠ WARNING Risk of an accident if the ball neck is not locked</p> <p>If the ball neck is not in the locked position, the trailer may come loose.</p> <ul style="list-style-type: none">▶ Pull over and stop the vehicle safely as soon as possible, paying attention to road and traffic conditions. Do not continue driving under any circumstances.▶ Uncouple the trailer and secure it against rolling away.▶ Initiate a new swivelling procedure and do not re-couple the trailer until the display message disappears. <p>► Observe the messages in the multifunction display.</p> <p>If the trailer hitch swivels:</p> <ul style="list-style-type: none">► Wait until the ball neck has reached the operational position.

Warning/indicator lamp



Power steering system warning lamp

Possible causes/consequences and ► Solutions

The red power steering system warning lamp is lit while the engine is running.
The power steering assistance or the steering itself is malfunctioning.



▲ WARNING Risk of accident if steering capability is impaired

If the steering does not function as intended, the vehicle's operating safety is jeopardised.

- Pull over and stop the vehicle safely as soon as possible, paying attention to road and traffic conditions. Do not continue driving under any circumstances.
- Consult a qualified specialist workshop.

- Observe the messages in the multifunction display.

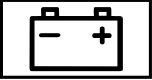
Engine

Warning/indicator lamp	Possible causes/consequences and ► Solutions
 <p data-bbox="118 350 437 412">Engine diagnosis warning lamp</p>	<p data-bbox="502 236 1453 265">The yellow engine diagnostics warning lamp is lit while the engine is running.</p> <p data-bbox="502 277 1504 306">A malfunction has occurred in the engine, the exhaust system or the fuel system.</p> <p data-bbox="502 319 1913 348">The emissions limit value may have been exceeded and the engine may be running in emergency operation mode.</p> <ul style="list-style-type: none"> <li data-bbox="502 360 1541 389">► Have the vehicle checked as soon as possible at a qualified specialist workshop. <p data-bbox="502 401 1361 430">Vehicles with a diesel engine: the fuel tank may have been run dry.</p> <ul style="list-style-type: none"> <li data-bbox="502 443 1958 534">► Start the engine three to four times after refuelling. If the yellow engine diagnostics warning lamp goes out, emergency operation mode is cancelled. The vehicle need not be checked.
 <p data-bbox="118 671 404 733">Electrical fault warning lamp</p>	<p data-bbox="502 557 1024 586">The red electrical fault warning lamp is lit.</p> <p data-bbox="502 598 887 627">There is a fault in the electrics.</p> <ul style="list-style-type: none"> <li data-bbox="502 640 1177 669">► Observe the messages in the multifunction display.
 <p data-bbox="118 862 445 891">Fuel reserve warning lamp</p>	<p data-bbox="502 749 1371 778">The yellow fuel reserve warning lamp is lit while the engine is running.</p> <p data-bbox="502 790 1140 819">The fuel supply has dropped into the reserve range.</p> <ul style="list-style-type: none"> <li data-bbox="502 831 635 860">► Refuel.

Warning/indicator lamp



Coolant warning lamp

Possible causes/consequences and ► Solutions

The red coolant warning lamp is lit while the engine is running.

Possible causes:

- The temperature sensor is malfunctioning
- Coolant level too low
- The air supply to the radiator is obstructed
- The radiator fan is faulty

If there is an additional warning tone, the coolant temperature has exceeded 120 °C.

▲ WARNING Danger of burns when opening the bonnet

If you open the engine bonnet when the engine has overheated or during a fire in the engine compartment, you could come into contact with hot gases or other escaping operating fluids.

- Before opening the bonnet, allow the engine to cool down.
- In the event of a fire in the engine compartment, keep the engine bonnet closed and call the fire service.

- Stop the vehicle immediately, paying attention to road and traffic conditions, and switch off the engine. Do not continue driving under any circumstances.
- Observe the messages in the multifunction display.

If the coolant temperature display is at the lower end of the temperature scale:

- Consult a qualified specialist workshop.

Warning/indicator lamp	Possible causes/consequences and ► Solutions
	<p>Otherwise:</p> <ul style="list-style-type: none"><li data-bbox="506 215 1708 246">► Leave the vehicle and keep a safe distance from the vehicle until the engine has cooled down.<li data-bbox="506 256 854 288">► Check the coolant level .<li data-bbox="506 298 1320 329">► Make sure that the air supply to the radiator is not obstructed.<li data-bbox="506 339 1984 407">► Avoiding high loads on the engine, drive on to the nearest qualified specialist workshop. In doing so, ensure that the coolant temperature display remains below 120 °C.

Tyres

Warning/indicator lamp



Tyre pressure monitoring system warning lamp lights up

Possible causes/consequences and ► Solutions

The yellow tyre pressure monitoring system warning lamp (pressure loss/malfunction) is lit.
The tyre pressure monitoring system has detected tyre pressure loss in at least one of the tyres.

▲ WARNING Risk of an accident due to insufficient tyre pressure

Tyres with insufficient tyre pressure pose the following risks:

- The tyres may burst, especially as the load and vehicle speed increase.
- The tyres may wear excessively and/or unevenly, which may greatly impair tyre traction.
- - The driving characteristics, steering and braking may be greatly impaired.

You could then lose control of the vehicle.

- Observe the recommended tyre pressures.
- Adjust the tyre pressure if necessary.

- Stop the vehicle, paying attention to road and traffic conditions.
- Check the tyre pressure and the tyres.

Warning/indicator lamp	Possible causes/consequences and ► Solutions
 <p data-bbox="118 301 431 394">Tyre pressure monitoring system warning lamp flashes</p>	<p data-bbox="502 184 1947 246">The yellow tyre pressure monitoring system warning lamp (pressure loss/malfunction) flashes for approximately one minute and then remains lit.</p> <p data-bbox="502 260 1069 291">The tyre pressure monitoring system is faulty.</p> <div data-bbox="502 311 1988 567" style="border: 1px solid black; padding: 5px;"><p data-bbox="519 322 1780 353">▲ WARNING There is a risk of an accident if the tyre pressure monitoring system is malfunctioning</p><p data-bbox="519 373 1947 436">If the tyre pressure monitoring system is malfunctioning, it is not able to issue a warning if there is pressure loss in one or more of the tyres.</p><p data-bbox="519 451 1913 513">Tyres with insufficient tyre pressure may, for example, affect the vehicle's handling characteristics, steering and braking. -</p><ul data-bbox="519 524 1627 555" style="list-style-type: none"><li data-bbox="519 524 1627 555">► Have the tyre pressure monitoring system checked at a qualified specialist workshop.</div> <p data-bbox="502 586 1038 617">► Consult a qualified specialist workshop.</p>

- 1, 2, 3 ...
- 12 V socket**
see Socket (12 V)
- 230 V socket**
see Socket (230 V)
- 360° Camera** 223
Care 317
Function 223
Selecting a view 226
- A**
- A/C function**
Activating/deactivating (control panel) 149
Activating/deactivating (multimedia system) 149
- ABS (Anti-lock Braking System)** 191
- Acceleration**
see Kickdown
- Access data**
Editing 294
Setting 293
- Acoustic locking verification signal**
Switching on/off 68
- Active Blind Spot Assist** 239
Activating/deactivating 241
Brake application 239
Function 239
System limitations 239
Trailer operation 239
- Active bonnet (pedestrian protection)** .. 307
Operation 307
Resetting 307
- Active Brake Assist**
Function/notes 196
Setting 201
- Active Distance Assist DISTRONIC** 205
Calling up a speed 207
Function 205
Increasing/decreasing speed 207
Lever 207
Requirements: 207
Selecting 207
Storing a speed 207
Switching off/deactivating 207
Switching on/activating 207
- System limitations 205
- Active headlamps function** 131
- Active Lane Keeping Assist** 241
Activating/deactivating 243
Function 241
Sensitivity (function/notes) 244
Setting the sensitivity 244
System limitations 241
- Active Parking Assist** 226
Cross Traffic Alert 237
Drive Away Assist 236
Exiting a parking space 230
Function 226
Parking 228
System limitations 226
- Active Steering Assist** 210
Activating/deactivating 211
Function 210
System limitations 210
- Adaptive brake lights** 201
- Adaptive cruise control**
see Active Distance Assist DISTRONIC

- Adaptive functions, MULTIBEAM LED**
see Intelligent Light System
- Adaptive Highbeam Assist**
Activating/deactivating 133
Function 132
- Adaptive Highbeam Assist Plus**
Activating/deactivating 135
Function 134
- AdBlue®** 372
Additives 372
Filling capacity 373
Notes 179
Purity 372
Topping up 179
- Additional door lock** 71
- Additives** 373
AdBlue® 372
Engine oil 373
Fuelling 371
- Additives (AdBlue®)**
see AdBlue®
- Additives (engine oil)**
see Additives
- Additives (fuel)**
see Fuelling
- Adjusting the balance/fader**
Burmester® surround sound system ... 305
- Adjusting the headlamp range** 128
- Adjusting the sound optimisation**
Burmester® surround sound system ... 305
- ADS PLUS damping system**
see AIR BODY CONTROL
- Adverse weather light** 132
- After-sales service centre**
see ASSYST PLUS
- AIR BODY CONTROL** 213
Setting 215
Suspension 213
- Air conditioning system**
see Climate control
- Air distribution** 147
- Air freshener system**
see Fragrance system
- Air suspension**
see AIR BODY CONTROL
- Air vents** 157
Adjusting (front) 157
Adjusting (rear) 158
Glove box 158
- Air vents**
see Air vents
- Air-recirculation mode** 150
- Airbag** 38
Activation 32
Belt airbag 36
Front airbag (driver, front passenger) 38
Installation locations 38
Knee airbag 38
Overview 38
Protection 39
Reduced protection 40
Side impact airbag 38
Windowbag 38
- Airflow** 147
- AIRPANEL (Care)** 317
- Alarm**
see Panic alarm

- Alarm system**
see ATA (anti-theft alarm system)
- Ambient lighting** 136
- Animals**
Pets in the vehicle 65
- Anti-lock braking system**
see ABS (Anti-lock Braking System)
- Anti-skid chains**
see Snow chains
- Anti-theft alarm system**
see ATA (anti-theft alarm system)
- Anti-theft protection**
Additional door lock 71
Immobiliser 91
- Anti-theft protection**
see ATA (anti-theft alarm system)
- Anticipatory occupant protection**
see PRE-SAFE® (anticipatory occupant protection)
see PRE-SAFE® PLUS (anticipatory occupant protection plus)
- Ashtray**
Front centre console 120
- Rear passenger compartment 121
- Assistance graphic**
Menu (on-board computer) 256
- Assistance systems**
see Driving safety system
- ASSYST PLUS** 306
Battery disconnection periods 307
Displaying the service due date 306
Function/notes 306
Regular maintenance work 306
Special service requirements 306
- ATA (anti-theft alarm system)** 91
Deactivating the alarm 92
Function 91
Function of interior protection 93
Tow-away protection function 92
- ATTENTION ASSIST** 237, 238
Activating/deactivating 238
Function 237
System limitations 237
- Attention assistant**
see ATTENTION ASSIST
- Audio 20**
see Multimedia system
- Audio mode**
Activating media mode 296
Connecting USB devices 297
Copyright 296
Information 295
Inserting/removing SD memory card
..... 296
Media search 298
Overview 297
Pause and playback function 298
Selecting a track 297
Selecting playback options 297
Track list 297
- Authorised workshop**
see Qualified specialist workshop
- Automatic distance control**
see Active Distance Assist DISTRONIC
- Automatic driving lights** 128
- Automatic engine start (ECO start/stop function)** 166
- Automatic engine stop (ECO start/stop function)** 166









- Automatic front passenger airbag shutoff** 41
 Function of the automatic front passenger airbag shutoff 41
- Automatic front passenger front airbag deactivation system** 41, 42
 PASSENGER AIR BAG indicator lamp 42
- Automatic front passenger front airbag deactivation system**
 see Automatic front passenger front airbag deactivation system
- Automatic mirror folding function**
 Activating/deactivating 145
- Automatic transmission**
 DIRECT SELECT lever 172
 Drive program display 170
 Drive programs 170
 DYNAMIC SELECT switch 170
 Engaging drive position 173
 Engaging reverse gear 173
 Kickdown 175
 Manual gearshifting 174
 Selecting park position 173
 Shifting to neutral 173
- Steering wheel gearshift paddles 174
 Transmission position display 172
 Transmission positions 172
- Axle load**
 Permissible 366
 Trailer operation 380
- B**
- Ball neck**
 Extending/retracting 245
- BAS (Brake Assist System)** 191
- Battery**
 Charging (Remote Online) 163
 Key 69
 Remote control (stationary heater) 156
- Battery (vehicle)**
 Charging 332
 Notes 330
 Starting assistance 332
- Belt**
 see Seat belt
- Belt airbag**
 Activation 32
- Function/notes 36
- Bicycle rack**
 Trailer operation 248
- Blind Spot Assist** 239
 Activating/deactivating 241
 Function 239
 System limitations 239
- Blower**
 see Climate control
- BlueTEC**
 see AdBlue®
- Bluetooth®**
 Activating/deactivating 275
 Settings 274
- Bluetooth® Audio**
 Activating 300
 Adjusting the volume 300
 Displaying device details 301
 Information 299
 Overview 299
 Searching for and authorising the device 299

















- Boot box**
see EASY-PACK boot box
- Boot lid**
Activating/deactivating the boot lid opening limiter 81
Closing 77
HANDS-FREE ACCESS 79
Locking separately 81
Opening 76
Opening dimensions 376
- Brake Assist System**
see BAS (Brake Assist System)
- Brake fluid**
Notes 374
- Brake force distribution**
EBD (Electronic Brake force Distribution) 196
- Brakes**
ABS (Anti-lock Braking System) 191
Active Brake Assist 196
Adaptive brake lights 201
BAS (Brake Assist System) 191
Driving tips 164
- EBD (Electronic Brake force Distribution) 196
HOLD function 212
Limited braking effect (salt-treated roads) 164
New/replaced brake linings/brake discs 164
Running-in notes 164
- Braking assistance**
see BAS (Brake Assist System)
- Breakdown**
Assistance overview 18
Tow-starting 340
Towing away 336
Transporting the vehicle 338
Wheel change 357
- Breakdown**
see Flat tyre
- Breakdown assistance call**
see Service call
- Breakdown management**
see Service call
- Burmester® surround sound system** 305
Adjusting the balance/fader 305
- Adjusting the sound optimisation 305
Adjusting treble, mid and bass 305
Calling up the sound menu 305
Information 305
Switching the surround sound on/off 305
- Buttons**
Steering wheel 252
- C**
- Call lists**
Calling up the speed dial list 285
Deleting speed dial presets 285
Displaying details from a list entry 285
Making a call 285
Overview 285
Setting up a speed dial list 285
- Calling up the sound menu**
Burmester® surround sound system ... 305
- Calls** 282
Accepting 282
Activating functions during a call 282
Calls with several participants 282
Declining 282

























- Ending a call 282
- Incoming call during an existing call 283
- Making 282
- Via the overhead control panel
(Mercedes me connect) 288
- Camera**
see 360° Camera
see Reversing camera
- Car key**
see Key
- Car wash**
see Care
- Car wash (care)** 314
- Care** 319
 - AIRPANEL 317
 - Car wash 314
 - Carpet 319
 - Display 319
 - EASY-PACK boot box 319
 - Exhaust pipes 317
 - Exterior lighting 317
 - Genuine wood/trim elements 319
 - High-pressure cleaner 314
 - Matt finish 316
 - Paintwork 316
 - Plastic trim 319
 - Reversing camera/360° Camera 317
 - Roof lining 319
 - Seat belt 319
 - Seat cover 319
 - Sensors 317
 - Trailer tow hitch 317
 - Washing by hand 315
 - Wheels/rims 317
 - Windows 317
 - Wiper blades 317
- Carpet (Care)** 319
- Changing bulbs** 137
 - Dipped beam 138
 - Fitting/removing cover (front wheel arch) 138
 - Main beam 138
 - Notes 137
 - Opening/closing the side trim panels 139
 - Overview 137
 - Reversing light 139
 - Turn signal light (front) 138
 - Turn signal light (rear) 139
- Changing hub caps** 357
- Changing the lights**
Driving abroad (symmetrical dipped beam) 127
- Channel tracking**
Setting 303
- Charging**
Battery (vehicle) 332
Mobile phone (wireless) 124
USB port 124
- Chassis level (AIR BODY CONTROL)**
Setting 215
- Child safety lock**
Rear side windows 65
- Child seat**
Attaching (notes) 54
Front passenger seat (notes) 52
Front passenger seat (rearward-facing/forward-facing) 54
Front passenger seat (without airbag shutoff) 53
ISOFIX/i-Size (fitting) 50
Notes 46
Recommended child restraint systems .. 61



























- Seats suitable for belt-secured child restraint systems 55
- Seats suitable for i-Size child restraint systems 60
- Seats suitable for ISOFIX child restraint systems 58
- Top Tether 51
- Child seat**
 - see i-Size child seat securing system
 - see ISOFIX child seat securing system
- Child-safety lock**
 - Rear door 63
- Children**
 - Restraint systems 46
- Chock** 356
 - Storage location 356
- Cigarette lighter**
 - Front centre console 121
- City lighting** 132
- Cleaning**
 - see Care
- Climate control** 147
 - Activating/deactivating the A/C function (control panel) 149
 - Activating/deactivating the A/C function (multimedia system) 149
 - Activating/deactivating the synchronisation function (control panel) 150
 - Activating/deactivating the synchronisation function (multimedia system) 150
 - Air distribution settings 150
 - Air-recirculation mode 150
 - Automatic control 149
 - Climate style function 149
 - Demisting the windows 150
 - Demisting the windscreen 147
 - Fragrance system 151
 - Front air vents 157
 - Glove box air vent 158
 - Inserting/removing the flacon (fragrance system) 151
 - ionisation 151
 - Note 147
 - Rear air vents 158
 - Rear operating unit 147
 - Residual heat 151
- Setting the air distribution 147
- Setting the airflow 147
- Setting the climate style 149
- Setting the temperature 147
- Stationary heater/ventilation 153
- Switching on/off 148
- Switching the rear window heater on/off 147
- THERMATIC control panel 147
- THERMOTRONIC control panel 147
- Ventilating the vehicle (convenience opening) 84
- Windscreen heater 152
- Climate style**
 - Function 149
 - Setting 149
- Cockpit** 6
 - Overview 6
- Combination switch**
 - see Turn signal light
- Computer**
 - On-board computer 253
- Connection status**
 - Displays 295



- Overview 295
 - Controller**
 - Operating 266
 - Convenience closing** 85
 - Convenience opening** 84
 - Coolant (engine)**
 - Level check 312
 - Notes 375
 - Cooling**
 - see Climate control
 - Copyright** 30
 - Cornering light** 131
 - Cover** 81
 - Cross Traffic Alert** 237
 - Crosswind Assist**
 - Function/notes 195
 - Cruise control**
 - Activating 203
 - Calling up a speed 203
 - Deactivating 203
 - Lever 203
 - Requirements 203
 - Selecting 203
 - Setting a speed 203
 - Storing a speed 203
 - Cruise control:** 201
 - Function 201
 - System limitations 201
 - Cup holder**
 - Rear 120
 - Cup holder in the centre console**
 - Installing/removing 119
 - installing/removing (automatic transmission) 118
- D**
- Damage detection (parked vehicle)** 189
 - Dashboard**
 - see Cockpit
 - Dashboard lighting**
 - see Instrument lighting
 - Data acquisition**
 - Vehicle 28
 - Data import/export**
 - Importing/exporting 275
 - Deactivating the alarm (ATA)** 92
 - Declaration of conformity**
 - Electromagnetic compatibility 24
 - Jack 24
 - TIREFIT kit 25
 - Wireless vehicle components 24
 - Designs**
 - Menu (on-board computer) 262
 - Diagnostics connection** 26
 - Diesel**
 - Low outside temperatures 371
 - Notes 371
 - Digital Car Key sticker**
 - Locking the vehicle 72
 - Starting the vehicle 161
 - Unlocking the vehicle 72
 - Digital Owner's Manual** 20
 - Digital speedometer** 257
 - Dipped beam**
 - Activating/deactivating 127
 - Changing bulbs 138
 - Setting 135
 - PIN protection for data export** 276

- Setting for abroad 127
- DIRECT SELECT lever** 172
- Engaging drive position 173
- Engaging park position automatically .. 173
- Engaging reverse gear 173
- Function 172
- Selecting park position 173
- Shifting to neutral 173
- Display**
- Care 319
- Display (multimedia system)**
- Notes 264
- Settings 273
- Switching off 273
- Display (on-board computer)**
- Displays in the multifunction display ... 255
- Display content**
- (Additional value range) 254
- Display message** 381
- Calling up (on-board computer) 381
- Notes 381
- Display messages**
-  415
-  433
-  433
-  434
-  408
-  405
- Active Blind Spot Assist currently unavailable See Owner's Manual 403
- Active Blind Spot Assist inoperative 403
- Active Blind Spot Assist not available when towing a trailer See Owner's Manual 403
- Active bonnet malfunction See Owner's Manual 432
- Active Brake Assist Functions currently limited See Owner's Manual 393
- Active Brake Assist Functions limited See Owner's Manual 394
- Active Distance Assist available again 404
- Active Distance Assist currently unavailable See Owner's Manual 404
- Active Distance Assist inoperative 404
- Active Lane Keeping Assist Camera view restricted See Owner's Manual ... 402
- Active Lane Keeping Assist currently unavailable See Owner's Manual 401
- Active Lane Keeping Assist inoperative 401
-  Active Light System inoperative 435
- Active Parking Assist and PARKTRONIC inoperative See Owner's Manual 404
-  Active Steering Assist currently unavailable See Owner's Manual 405
-  Active Steering Assist inoperative 405
- Adaptive Highbeam Assist Camera view restricted See Owner's Manual ... 438

- Adaptive Highbeam Assist currently unavailable See Owner's Manual 438
- Adaptive Highbeam Assist inoperative 437
- Adaptive Highbeam Assist Plus Camera view restricted See Owner's Manual 437
- Adaptive Highbeam Assist Plus currently unavailable See Owner's Manual 437
- Adaptive Highbeam Assist Plus inoperative 436
-  Add 1 litre engine oil when next refuelling 413
- Air conditioning Malfunction See Owner's Manual 428
- Apply brake to deselect Park (P) position 425
- Apply brake to select R 429
-  ATTENTION ASSIST inoperative 399
-  ATTENTION ASSIST: Take a break! 399
-  AUTO lights inoperative 436
- Auxiliary battery malfunction 427
-  Before starting the engine, turn the steering wheel. 429
- Blind Spot Assist currently unavailable See Owner's Manual 402
- Blind Spot Assist inoperative 403
- Blind Spot Assist not available when towing a trailer See Owner's Manual ... 403
- Brake immediately 391
-  Change key batteries 422
-  Check AdBlue See Owner's Manual 416
-  Check brake fluid level 391
-  Check eng. oil lev. when next refuelling 411
-  Check trailer hitch lock 424
-  Check tyre(s) 418
-  Clean the fuel filter 414
- Clutch overheated Avoid pulling away for XX:XX mins 428
-  Coolant Stop vehicle Switch engine off 407
- Cruise control and Limiter inoperative 406
- Cruise control inoperative 405
- Cruise control off 405
-  currently unavailable See Owner's Manual 383
-  currently unavailable See Owner's Manual 384
- Depress clutch fully to start engine 428
- LIM** 406
-  Eng. start not possible in XXX km 416
-  Eng. start not possible 416

- | | | |
|--|---|--|
|  Engine oil level cannot be measured 414 |  Intelligent Light System inoperative 435 | Only select Park (P) when vehicle is stationary 426 |
|  Engine oil level Reduce oil level .. 412 |  Key not detected (red display message) 422 |  Operation only possible in transmission position N 429 |
|  Engine oil level Stop vehicle Switch engine off 412 |  Key not detected (white display message) 422 |  Operation only possible in transmission position P 429 |
|  Engine oil pressure Stop Switch off engine 413 |  Left dipped beam (example) 435 |  Parking brake See Owner's Manual 388 |
|  Front left malfunction Consult workshop (example) 396 |  Left windowbag malfunction Consult workshop (example) 396 |  Place the key in the marked space See Owner's Manual 423 |
| Front-passenger airbag disabled See Owner's Manual 397 | Let fresh air into the vehicle interior! Air conditioning malf. Visit workshop .. 430 | PRE-SAFE impulse side inoperative See Owner's Manual 394 |
| Front-passenger airbag enabled See Owner's Manual 398 | Limiter inoperative 406 | PRE-SAFE inoperative See Owner's Manual 394 |
|  inoperative See Owner's Manual 382 | Limiter passive 405 | Radar sensors dirty See Owner's Manual 392 |
|  inoperative See Owner's Manual 385 |  Lowering 399 |  Rear left seat backrest not locked (example) 434 |
|  inoperative See Owner's Manual 386 |  Malfunction See Owner's Manual 436 |  Rectify tyre pressure 418 |
|  Inoperative 392 |  Maximum speed exceeded 406 | |
| | N permanently active Risk of vehicle rolling 426 | |
| |  Off 404 | |

 Refill AdBlue Eng. start not possible 415	 Start engine See Owner's Manual 408	To shift out of P or N, depress brake and start engine 425
 Refill AdBlue No start in XXX km 415	 Steering malfunction Drive carefully Visit workshop 431	Top up coolant See Owner's Manual ... 407
 Refill AdBlue See Owner's Manual 415	 Steering malfunction Increased physical effort See Owner's Manual 432	 Top up washer fluid 434
 Release parking brake 387	 Steering malfunction See Owner's Manual 430	 Trailer coupling extending... 423
 Replace air cleaner 414	 Steering malfunction Stop immediately See Owner's Manual 431	Transmission Malfunction Stop 427
 Replace key See Owner's Manual 421	Stop vehicle Leave engine running Wait Transmission cooling 427	 Turn on the ignition to release the parking brake 386
 Replace key 421	 Steering malfunction Stop vehicle Leave engine running 411	Tyre press. monitor currently unavailable 419
 Reserve fuel level 414	 Stop vehicle See Owner's Manual 409	Tyre press. monitor inoperative 420
 Restraint sys. malfunction Consult workshop 395	 Stop vehicle Vehicle too low 400	Tyre press. monitor inoperative No wheel sensors 420
Reversing not poss. Consult workshop 427	 Switch off lights 436	Tyre pressure Check tyres 417
Risk of vehicle rolling Driver door open and transmission not in P 425	 Switch on headlamps 436	Tyre(s) overheated 420
 See Owner's Manual 408		Tyre(s) overheated Reduce speed 421
Speed limit (winter tyres) XXX km/h ... 406		 Vehicle is operational Switch off the ignition before exiting 426
		 Vehicle rising Please wait 400
		 Vehicle rising 399

-  **Warning tyre defect** 419
-  **Wheel sensor(s) missing** 420
- Without changing gear, consult workshop** 426
- Display on the windscreen**
see Head-up display
- Distance control**
see Active Distance Assist DISTRONIC
- Distance recorder**
see Trip distance
- DISTRONIC**
see Active Distance Assist DISTRONIC
- Door**
 - Additional door lock 71
 - Locking (emergency key) 76
 - Opening (from the inside) 71
 - Unlocking (emergency key) 76
 - Unlocking (from the inside) 71
- Door control panel** 16
- Drive Away Assist** 236
- Drive position**
 - Selecting 173
- Drive program display** 170
- Drive programs**
see DYNAMIC SELECT
- Driver's seat**
see Seat
- Driving lights**
see Automatic driving lights
- Driving safety system** 190
 - ABS (Anti-lock Braking System) 191
 - Active Brake Assist 196
 - Adaptive brake lights 201
 - BAS (Brake Assist System) 191
 - EBD (Electronic Brake force Distribution) 196
 - ESP® (Electronic Stability Program)
Crosswind Assist 195
 - ESP® (Electronic Stability Program)
trailer stabilisation 195
 - Overview 191
 - Radar sensors 190
 - Responsibility 190
 - STEER CONTROL 196
- Driving system**
DYNAMIC BODY CONTROL 213
- Driving system**
 - see 360° Camera
 - see Active Blind Spot Assist
 - see Active Distance Assist DISTRONIC
 - see Active Lane Keeping Assist
 - see Active Parking Assist
 - see Active Steering Assist
 - see AIR BODY CONTROL
 - see ATTENTION ASSIST
 - see Blind Spot Assist
 - see Cruise control:
 - see Driving safety system
 - see HOLD function
 - see Limiter
 - see Parking Assist PARKTRONIC
 - see Remote Parking Assist
 - see Reversing camera
- Driving tips**
 - Driving abroad (changing the lights) 127
 - General driving tips 164
 - Running-in notes 164
- Drowsiness detection**
see ATTENTION ASSIST
- DYNAMIC BODY CONTROL**
 - Suspension 213

- Dynamic handling control system**
see ESP® (Electronic Stability Program)
- DYNAMIC SELECT** 170
Configuring drive program I 170
Drive program display 170
Drive programs 170
Function 170
Operating (DYNAMIC SELECT switch)
..... 170
Selecting the drive program 170
- E**
- E-mails**
see Messages
- E10** 370
- Easy entry feature**
Function/notes 105
Setting 106
- Easy exit feature**
Function/notes 105
Setting 106
- EASY-PACK boot box** 116
Adjusting the height to any position 114
Care 319
- Installing/removing 116
- EBD (Electronic Brake force Distribution)**
Function/notes 196
- ECO Assist**
Displaying 169
Function/notes 168
- ECO display**
Function 168
Resetting 258
- ECO start/stop function** 166, 167
Automatic engine start 166
Automatic engine stop 166
Operation 166
Switching off/on 167
- Electric parking brake** 186, 187, 188, 189
Applying automatically 186
Applying or releasing manually 188
Emergency braking 189
Releasing automatically 187
- Electrical fuses**
see Fuses
- Electromagnetic compatibility**
Declaration of conformity 24
- Electronic Stability Program**
see ESP® (Electronic Stability Program)
- Electronics** 364
- Emergency**
Assistance overview 18
Fire extinguisher 324
First-aid kit (soft sided) 323
Removing the warning triangle 323
Safety vest 322
Setting up the warning triangle 323
- Emergency braking** 189
- Emergency call system**
see Mercedes-Benz emergency call system
- Emergency engine start** 340
- Emergency key element**
Inserting/removing 69
Locking a door 76
Unlocking a door 76
- Emergency operation mode**
Starting the vehicle 162

- | | | | | | |
|---|-----|--|-----|---|-----|
| Emergency spare wheel | 362 | Engine oil | 311 | Exhaust pipes (Care) | 317 |
| Notes | 362 | Additives | 373 | Exterior lighting | |
| Removing | 363 | Checking the oil level using the oil dipstick | 310 | Care | 317 |
| Energy consumption | | Checking the oil level using the on-board computer | 310 | Exterior lighting | |
| Key | 68 | Filling capacity | 374 | see Lights | |
| Engine | | MB-Freigabe or MB-Approval | 374 | | |
| ECO start/stop function | 166 | Quality | 374 | | |
| Engine number | 366 | Topping up | 311 | | |
| Starting (Digital Car Key sticker) | 161 | Entering characters | | | |
| Starting (emergency operation mode) | 162 | Function/notes | 271 | | |
| Starting (mobile phone) | 161 | On the touchpad | 272 | | |
| Starting (Remote Online) | 163 | Using the controller | 272 | | |
| Starting (start/stop button) | 160 | ESC (Electronic Stability Control) | | | |
| Starting assistance | 332 | see ESP® (Electronic Stability Program) | | | |
| Switching off (start/stop button) | 181 | ESP® | | | |
| Engine bonnet | | Crosswind Assist | 195 | | |
| Function (active bonnet) | 307 | Trailer stabilisation | 195 | | |
| Opening/closing | 308 | ESP® (Electronic Stability Program) | 192 | | |
| Resetting (active bonnet) | 307 | Function/notes | 192 | | |
| Engine electronics | | Switching on/off | 195 | | |
| Notes | 364 | EU general operating permit number | 366 | | |
| Engine number | 366 | | | Fatigue detection | |
| | | | | see ATTENTION ASSIST | |
| | | | | Fault message | |
| | | | | see Display message | |
| | | | | Favourites | |
| | | | | Adding | 270 |
| | | | | Calling up | 269 |
| | | | | Deleting | 270 |
| | | | | Moving | 270 |
| | | | | Overview | 269 |
| | | | | Renaming | 270 |
| | | | | Fire extinguisher | 324 |
| | | | | First-aid kit (soft sided) | 323 |
| | | | | Flacon | |
| | | | | Inserting/removing | 151 |

F

- | | | | | | |
|---|-----|----------------------------------|-----|--|-----|
| Flat tyre | 324 | Front passenger seat | | Fuse insert | |
| MOExtended tyres | 325 | see Seat | | see Fuses | |
| Notes | 324 | Front wheel arch | | Fuses | 341 |
| TIREFIT kit | 326 | Fitting/removing the cover | 138 | Assignment diagram | 341 |
| Wheel change | 357 | Front wheel arch cover | | Before replacing a fuse | 341 |
| Floor mats | 126 | Fitting/removing | 138 | Fuse box in the boot | 343 |
| Fog light (extended range) | 132 | Fuel | | Fuse box in the engine compartment .. | 342 |
| Fragrance | | E10 | 370 | Fuse box in the front-passenger foot- | |
| see Fragrance system | | Petrol | 370 | well | 343 |
| Fragrance system | 151 | Quality (petrol) | 370 | Fuse box on the dashboard | 343 |
| Adjusting the fragrance intensity | 151 | Reserve fuel level | 372 | Notes | 341 |
| Inserting/removing the flacon | 151 | Sulphur content | 370 | | |
| Switching on/off | 151 | Tank capacity | 372 | | |
| Free software | 30 | Fuel consumption | | | |
| Frequencies | | On-board computer | 257 | G | |
| Mobile phone | 365 | Fuelling | 371 | Garage door opener | |
| Two-way radio | 365 | Additives | 371 | Clearing the memory | 185 |
| Frequency band | | Diesel | 371 | Opening/closing the garage door | 184 |
| Selecting (on-board computer) | 259 | Low outside temperatures | 371 | Programming buttons | 182 |
| Front airbag (driver, front passenger) | 38 | Quality (diesel) | 371 | Radio equipment approval numbers | 185 |
| Front passenger seat | | Refuelling | 176 | Resolving problems | 184 |
| Adjusting from the driver's seat | 98 | Function seat | | Synchronising the rolling code | 183 |
| | | see Door control panel | | Garmin® MAP PILOT navigation mod- | |
| | | | | ule | |
| | | | | Activating | 277 |
| | | | | Overview | 276 |

Gearshift paddles	
see Steering wheel gearshift paddles	
Gearshift recommendation	171, 174
General operating permit number (EU)	366
Genuine parts	22
Genuine wood (Care)	319
Glide mode	175
Glove box	
Air vent	158
Locking/unlocking	109
Gross weight	366

H

Handbrake	
see Electric parking brake	
Handling characteristics (unusual)	344
HANDS-FREE ACCESS	79
Hazard warning lights	130
Head restraint	99
Front (adjusting manually)	99
Front (luxury head restraint)	100
Rear (adjusting)	101
Rear (fitting/removing)	101
Head-up display	261
Adjusting brightness (on-board computer)	261
Adjusting display elements (on-board computer)	261
Function	262
Menu (on-board computer)	261
Setting the position (on-board computer)	261
Switching on/off	263
Using the memory function	106
Headlamp flasher	129
Heating	
see Climate control	
High-pressure cleaner (care)	314
Hill Start Assist	211
HOLD function	212
Activating/deactivating	212
Function/notes	212
Hooking the luggage net	114

I

i-Size child seat securing system	49
Fitting	50
Notes	49
Seats suitable for attaching	60
Identification plate	
Engine	366
Vehicle	366
Ignition	
Switching on (Start/Stop button)	159
Ignition key	
see Key	
Immobiliser	91
Implied warranty	
Vehicle	27
Inattentiveness assistant	
see ATTENTION ASSIST	
Indicator lamp	
see Warning/indicator lamps	
Individual drive program	
Configuring	170
Selecting	170

- Instrument cluster**
 - see Instrument Display
 - see Warning/indicator lamps
 - Instrument Display** 251
 - Adjusting the lighting 255
 - Function/notes 251
 - Overview 10, 251
 - Warning/indicator lamps 438
 - Instrument lighting** 255
 - Intelligent Light System** 130
 - Active headlamps function 131
 - Adaptive Highbeam Assist Plus 134
 - Adverse weather light 132
 - City lighting 132
 - Cornering light 131
 - Fog light (extended range) 132
 - Motorway mode 131
 - Overview 130
 - Switching on/off 132
 - Interior lighting** 136
 - Ambient lighting 136
 - Setting 136
 - Switch-off delay time 136
 - Interior lighting**
 - see Interior lighting
 - see Lighting
 - see Lights
 - Interior protection**
 - Function 93
 - Switching on/off 93
 - Internet connection**
 - Cancelling permission 294
 - Closing 294
 - Connection status 295
 - Displaying the connection status 295
 - Editing access data 294
 - Establishing 294
 - Mobile phone details 294
 - Restrictions 293
 - Setting access data 293
 - Setting up 293
 - Ionisation** 151
 - ISOFIX child seat securing system** 49
 - Fitting 50
 - Notes 49
 - Seats suitable for attaching 58
- J**
- Jack**
 - Declaration of Conformity 24
 - Storage location 356
 - Jump-start connection** 332
- K**
- Key** 67
 - Battery 69
 - Emergency key element 69
 - Energy consumption 68
 - Features 67
 - Key ring attachment 69
 - Overview 67
 - Panic alarm 68
 - Problem 70
 - Unlocking setting 68
 - KEYLESS-GO**
 - Locking the vehicle 73
 - Problem 74
 - Unlocking setting 68
 - Unlocking the vehicle 73
 - Kickdown** 175
 - Using 175

Knee airbag 38

L

Laden 113

Stowage space under the boot floor 117

Tie-down eyes 113

Lamp (instrument display)

see Warning/indicator lamps

Lamps

see Interior lighting

Lane Keeping Assist

see Active Lane Keeping Assist

Language

Setting 275

LED light

see Intelligent Light System

Level control system

see AIR BODY CONTROL

Light switch

Overview 127

Lighting 136

Lighting

see Lights

Lights 127, 136

Active headlamps function 131

Adaptive Highbeam Assist 132

Adaptive Highbeam Assist Plus 134

Adjusting the instrument lighting 255

Adverse weather light 132

Automatic driving lights 128

Changing bulbs 137

City lighting 132

Combination switch 129

Cornering light 131

Dipped beam 127

Driving abroad 127

Fog light (extended range) 132

Hazard warning lamps 130

Headlamp flasher 129

Headlamp range 128

Intelligent Light System 130

Light switch 127

Main beam 129

Motorway mode 131

Parking lights 127

Rear fog light 128

Responsibility for lighting systems 127

Setting the dipped beam 135

Standing lights 127

Turn signal light 129

Limiter 202

Activating 203

Calling up a speed 203

Deactivating 203

Function 202

Lever 203

Passive mode 202

Permanent setting 204

Requirements 203

Selecting 203

Setting a speed 203

Storing a speed 203

System limitations 202

Limiting speed

see Limiter

Loading

Notes 107

Roof rack 117

Loading guidelines 107

Loads	
Securing	107
Locator lighting	
Switching on/off	135
Locking/unlocking	
Additional door lock	71
Digital Car Key sticker	72
KEYLESS-GO	73
Mobile phone	72
Smartphone	72
Unlocking/opening the doors from the inside	71
Lubricant additives	
see Additives	
Luggage	
Luggage net	114
Securing	107
Lumbar support	
see Lumbar support (4-way)	
Lumbar support (4-way)	99

M

Main beam	
Activating/deactivating	129
Adaptive Highbeam Assist	132
Adaptive Highbeam Assist Plus	134
Changing bulbs	138
Maintenance	
see ASSYST PLUS	
Malfunction	
Restraint system	32
Manual transmission	
Operating the gearshift lever	170
Matt finish (cleaning instructions)	316
Maximum gross vehicle weight	366
Maximum speed	
see Limiter	
MB Info call	
see Service call	
Media	
Menu (on-board computer)	260
Searching	298

Media Interface	
Information	298
Overview	299
Switching on	299
Media mode	
Activating	296
Media playback	
Operating (on-board computer)	260
Media search	
Starting	298
Media source	
Dialling (on-board computer)	260
Memory function	
Head-up display – Calling up saved settings	106
Head-up Display – Saving settings	106
Operating	106
Outside mirror – Calling up saved settings	106
Outside mirror – Saving settings	106
Seat – Calling up saved settings	106
Seat – Saving settings	106
Steering wheel – Calling up saved settings	106

- Steering wheel – Saving settings 106
- Menu (on-board computer)**
- Assistance graphic 256
 - Designs 262
 - Media 260
 - Navigation 258
 - Overview 253
 - Radio 259
 - Service 256
 - Telephone 260
 - Trip 257
- Mercedes me connect**
- accident management 289
 - Arranging a service appointment 289
 - Breakdown assistance call 289
 - Calling the Mercedes-Benz Customer Centre 287
 - Consenting to data transfer 289
 - Information 287
 - Making a call via the overhead control panel 288
 - MB Info call 288
 - Transferred data 290
- Mercedes-AMG vehicles**
- Notes 159
- Mercedes-Benz emergency call system** 290
- Automatic emergency call 291
 - Information 290
 - Manual emergency call 291
 - Overview 290
 - Transferred data 292
- Mercedes-Benz Service Centre**
- see Qualified specialist workshop
- Message (multifunction display)**
- see Display message
- Message memory** 381
- Messages** 286
- Making a call 286
 - Notes 286
 - Reading 286
 - Settings 286
- Mirrors**
- see Outside mirrors
- Mobile phone**
- Authorising (Remote Parking Assist) ... 236
 - Cancelling permission for Internet connection 294
 - Damage detection (parked vehicle) 189
 - Frequencies 365
 - Locking the vehicle 72
 - Starting the vehicle 161
 - Transmission output (maximum) 365
 - Unlocking the vehicle 72
 - Wireless charging 125
- Mobile phone**
- see Telephone
- Model series** 366
- MOExtended tyres** 325
- Motorway mode** 131
- MULTIBEAM LED**
- see Intelligent Light System
- Multifunction display (on-board computer)** 255
- Multifunction steering wheel**
- Overview of buttons 252
- Multifunction steering wheel**
- see Steering wheel
- Multimedia system** 264, 273
- Activating/deactivating standby mode 190
 - Adjusting the volume 271

- Calling up menus 268
 - Central control elements 264
 - Configuring display settings 273
 - Main functions 268
 - Overview 264
 - Restoring the factory settings 276
 - Switching the sound on/off 271
- N**
- Navigation**
 - Menu (on-board computer) 258
 - Navigation messages**
 - On-board computer 258
 - Near Field Communication (NFC)**
 - Locking the vehicle (digital vehicle key sticker) 72
 - Locking the vehicle (mobile phone) 72
 - Starting the vehicle (Digital Car Key sticker) 161
 - Starting the vehicle (mobile phone) 161
 - Unlocking the vehicle (digital vehicle key sticker) 72
 - Unlocking the vehicle (mobile phone) 72
- Neutral**
- Selecting 173
- O**
- Occupant safety**
 - Pets in the vehicle 65
 - Occupant safety**
 - see Airbag
 - see Automatic front passenger air-bag shutoff
 - see PRE-SAFE® (anticipatory occupant protection)
 - see PRE-SAFE® Impulse Side
 - see PRE-SAFE® PLUS (anticipatory occupant protection plus)
 - see Restraint system
 - see Seat belt
 - Odometer**
 - see Total distance recorder
 - Oil**
 - see Engine oil
 - On-board computer** 261
 - Assistance graphic menu 256
 - Displaying the service due date 306
 - Media menu 260
 - Menu designs 262
 - Menus 253
 - Multifunction display 255
 - Navigation menu 258
 - Operating 253
 - Radio menu 259
 - Service menu 256
 - Telephone menu 260
 - Trip menu 257
- On-board diagnostics interface**
- see Diagnostics connection
- On-board electronics**
- Engine electronics 364
 - Notes 364
 - Two-way radios 364
- Open-source software** 30
- Opening the boot lid using your foot**
- HANDS-FREE ACCESS 79
- Operating fluids**
- AdBlue® 372
 - Brake fluid 374
 - Coolant (engine) 375
 - Fuel (petrol) 370

- Notes 368
- windscreen washer fluid 376
- Operating safety**
 - Declaration of Conformity (electromagnetic compatibility) 24
 - Declaration of conformity (jack) 24
 - Declaration of conformity (TIREFIT kit) .. 25
 - Declaration of conformity (wireless vehicle components) 24
 - Information 23
- Operating system**
 - On-board computer 253
- Outside mirrors** 142, 143, 144
 - Anti-dazzle mode (automatic) 143
 - Automatic mirror folding function 145
 - Folding in/out 142
 - Parking position 144
 - Setting 142
 - Using the memory function 106
- Overhead control panel**
 - Making calls (Mercedes me connect) 288
 - Overview 14
- Owner's Manual**
 - Vehicle equipment 23
- Owner's Manual (digital)** 20
- P**
- Paint code** 366
- Paintwork (cleaning instructions)** 316
- Panic alarm** 68
 - Activating/deactivating 68
- Panoramic sliding sunroof**
 - see Sliding sunroof
- Park position**
 - Selecting 173
 - Selecting automatically 173
- Parking**
 - see Electric parking brake
- Parking aid**
 - see Parking Assist PARKTRONIC
- Parking Assist**
 - Manoeuvring assistance 237
- Parking Assist PARKTRONIC** 216
 - Adjusting warning tones 219
- Function 216
- Side impact protection 217
- Switching off 218
- Switching on 218
- System limitations 216
- Parking assistance systems**
 - see Active Parking Assist
- Parking brake**
 - see Electric parking brake
- Parking lights** 127
- Parking position**
 - Outside mirrors 144
 - Storing the position of the passenger outside mirror using reverse gear 144
- Parking up** 189
- PASSENGER AIR BAG status display**
 - see Automatic front passenger front airbag deactivation system
- Pedestrian protection**
 - see Active bonnet (pedestrian protection)
- Perfume**
 - see Fragrance system

- Perfume vial**
see Fragrance system
- Period out of use**
Activating/deactivating standby mode 190
- Permissible axle load** 366
- Permitted towing methods** 335
- Petrol** 370
- Pets in the vehicle** 65
- Phone book**
Deleting a contact 285
Display and sorting criteria 284
Downloading mobile phone contacts .. 283
Importing contacts 284
Overview 283
Saving a contact 284
Searching for a contact 284
- PIN protection for data export** 276
- Plastic trim (Care)** 319
- Playback options**
Selecting 297
- Plug-in hybrid operation**
Displaying ECO Assist 169
- Power supply**
Switching on (Start/Stop button) 159
- Power windows**
see Side windows
- PRE-SAFE® (anticipatory occupant protection)** 45
Function 45
PRE-SAFE® Sound 45
Reversing measures 45
- PRE-SAFE® Impulse Side** 46
Activation 32
Function 46
- PRE-SAFE® PLUS (anticipatory occupant protection plus)** 46
Function 46
Reversing measures 45
- Presets menu view**
Activating/deactivating 303
- Preventative occupant protection system**
see PRE-SAFE® (anticipatory occupant protection)
- Programs**
see DYNAMIC SELECT
- Protection of the environment**
Notes 21
Take-back of end-of-life vehicles 21
- Q**
- QR code**
Rescue card 27
- Qualified specialist workshop** 26
- R**
- Radar sensors** 190
- Radiator shutters**
see AIRPANEL (Care)
- Radio**
Activating 301
Activating/deactivating the presets view 303

- Calling up the station list 302
- Deleting stations 303
- Displaying information 304
- Displaying radio text 304
- Displaying the artist and track 304
- Editing station presets 303
- Frequency fix 303
- Menu (on-board computer) 259
- Moving stations 303
- Overview 301
- Searching for stations 301
- Setting a station 301
- Setting station tracking 303
- Setting the frequency band 301
- Sorting the station list 302
- Storing radio stations 302
- Switching traffic announcements
on/off 304
- Tagging music tracks 303
- Radio station list**
 - Sorting 302
- Radio stations**
 - Selecting (on-board computer) 259
- Rain-closing feature**
 - Sliding sunroof 89
- Range**
 - Displaying 257
- Reading light**
 - see Interior lighting
- Rear door (child safety lock)** 63
- Rear fog light** 128
- Rear seat**
 - see Seat
- Rear seat belt**
 - Status display 37
- Rear seat belt status display** 37
- Rear window**
 - Roller sunblind 82
- Rear window heater** 147
- Rear-view mirror**
 - see Outside mirrors
- Recycling**
 - see Take-back of end-of-life vehicles
- Reducing agent**
 - see AdBlue®
- Refuel**
 - Refuelling the vehicle 176
- Refuelling**
 - Topping up AdBlue® 179
- Registration**
 - Vehicle 27
- Remote control (stationary heater)**
 - Displays 155
 - Problems 157
 - Replacing the battery 156
 - Setting 154
- Remote Online**
 - Charging the battery 163
 - Cooling or heating the vehicle interior 162
 - Starting the vehicle 163
- Remote Parking Assist** 231
 - Authorising a mobile phone 236
 - Function 231
 - Operating 233
 - System limitations 231
- Replacing a bulb**
 - see Changing bulbs
- Rescue card** 27

Reserve	
Fuel	372
Reset function (multimedia system)	276
Residual heat	151
Restoring (factory settings)	
see Reset function (multimedia system)	
Restraint system	31
Children	46
Function in an accident	32
Functionality	32
Malfunction	32
Protection	31
Reduced protection	31
System self-test	32
Warning lamp	32
Reverse gear	
Selecting	173
Reversing camera	220
Care	317
Function	220
Opening the camera cover	223
Switching automatic mode on/off	222

Reversing camera (Active Parking Assist)	
Opening the camera cover	226
Switching automatic mode on/off	226
Reversing light (changing bulbs)	139
Rims (Care)	317
Roll away protection	
see HOLD function	
Roller sunblind	
Rear window	82
Side windows	81
Roller sunblind	
see Cover	
Roof lining (care)	319
Roof load	378
Roof rack	117
Run-flat characteristics	
MOExtended tyres	325
Running-in notes	164

S

Safety systems	
see Driving safety system	
Safety vest	322
SD memory card	
Inserting/removing	296
Seat	95, 110
4-way lumbar support	99
Adjusting (electrically)	98
Adjusting (manually and electrically)	95
Adjusting (Seat Comfort)	97
Backrest (rear) locking	112
Correct driver's seat position	94
Folding backrest (rear) forwards	110
Folding the backrest (rear) back	111
Setting options	16
Using the memory function	106
Seat	
see Head restraint	
Seat belt	33, 37
Activating/deactivating seat belt	
adjustment	37
Adjusting the height	36

- Belt airbag 36
- Care 319
- Fastening 36
- Protection 33
- Rear seat belt status display 37
- Reduced protection 34
- Releasing 37
- Seat belt adjustment (function) 36
- Warning lamp 37
- Seat belt adjustment**
 - Activating/deactivating 37
 - Function 36
- Seat belt tensioners**
 - Activation 32
- Seat belt warning**
 - see Seat belt
- Seat cover (Care)** 319
- Seat heater**
 - Activating/deactivating 101
- Seat ventilation**
 - Activating/deactivating 103
- Selecting a gear**
 - see Shifting gears
- Selector lever**
 - see DIRECT SELECT lever
- Sensors (Care)** 317
- Service**
 - Menu (on-board computer) 256
- Service**
 - see ASSYST PLUS
- Service call** 289
 - Breakdown assistance call 289
 - MB Info call 288
- Service Centre**
 - see Qualified specialist workshop
- Service interval display**
 - see ASSYST PLUS
- Service product**
 - Engine oil 373
- Service products**
 - Additives (fuel) 371
 - Fuel (diesel) 371
- Setting a speed**
 - see Cruise control:
- Setting summer time** 273
- Setting the date format** 274
- Setting the distance unit and temperature unit** 275
- Settings**
 - Messages 286
- Shifting gears** 174
 - Gearshift recommendation 171, 174
 - Manual 174
- Short text messages**
 - see Messages
- Side impact airbag** 38
- Side impact protection** 217
- Side windows** 83
 - Child safety lock in the rear 65
 - Closing 83
 - Closing using the key 85
 - Convenience closing 84
 - Convenience opening 84
 - Opening 83
 - Opening with the key 84
 - Problem 85
 - Roller sunblind 81
- Ski/snowboard bag** 112

- Sliding sunroof** 86
 - Automatic features 89
 - Closing 86
 - Closing using the key 85
 - Opening 86
 - Opening with the key 84
 - Problem 90
 - Rain-closing feature 89
- Smartphone**
 - Locking the vehicle 72
 - Unlocking the vehicle 72
- Smartphone**
see Telephone
- Snow chains** 345
- Socket (12 V)** 121
 - Boot 123
 - Front centre console 121
 - Rear passenger compartment 122
- Socket (230 V)** 122
 - Rear passenger compartment 122
- Sound**
 - PRE-SAFE® Sound 45
 - wheels and tyres 344
- Sound**
 - see Burmester® surround sound system
 - see Tone settings
- Spare wheel**
see Emergency spare wheel
- Spectacles compartment** 109
- Speed dial list**
 - Calling up 285
 - Deleting speed dial presets 285
 - Setting up 285
- Speed limit for winter tyres**
 - Setting 205
- Speedometer**
 - Digital 257
- Standby mode**
 - Activating/deactivating 190
 - Function 189
- Standing lights** 127
- Start/stop button**
 - Starting the vehicle 160
 - Switching off the vehicle 181
 - Switching on the power supply or ignition 159
- Start/stop function**
see ECO start/stop function
- Starting assistance**
see Jump-start connection
- Starting the engine**
see Vehicle
- Starting-off aid**
see Hill Start Assist
- Station**
 - Deleting 303
 - Frequency fix 303
 - Moving 303
 - Searching 301
 - Setting 301
 - Storing 302
- Station list**
 - Calling up 302
- Station presets**
 - Editing 303
- Stationary heater/ventilation**
 - Displays (remote control) 155
 - Problems (remote control) 157
 - Setting (remote control) 154

- Setting (using the multimedia system) 154
 Switching on/off (control panel) 153
- STEER CONTROL**
 Function/notes 196
- Steering wheel** 252
 Adjusting (electrically) 104
 Adjusting (manually) 103
 Buttons 252
 Steering wheel heater 105
 Using the memory function 106
- Steering wheel gearshift paddles** 174
- Steering wheel heater**
 Switching on/off 105
- Stowage areas**
 see Laden
 see Stowage compartment
- Stowage compartment** 108
 Armrest 108
 Centre console 108
 Door 108
 Glove box 108
 Rear armrest 109
 Spectacles compartment 109
- Stowage compartments**
 see Laden
 see Stowage compartment
- Stowage space under the boot floor** 117
- Sulphur content** 370
- Sun visor**
 Operating 145
- Surround View**
 see 360° Camera
- Suspension**
 Adjusting the chassis level (AIR BODY CONTROL) 215
 Damping characteristics 213
 DYNAMIC BODY CONTROL 213
- Suspension**
 see AIR BODY CONTROL
- Switch-off delay time**
 Exterior 135
 Interior 136
- Switching the surround sound on/off**
 Burmester® surround sound system ... 305
- Synchronisation function**
 Activating/deactivating (control panel) 150
 Activating/deactivating (multimedia system) 150
- System self-test**
 Automatic front passenger front air-bag deactivation system 42
- System settings**
 Language 275
 Reset function (multimedia system) 276
 Setting the distance unit and temperature unit 275
- System settings**
 see Multimedia system
- T**
- Take-back of end-of-life vehicles** 21
 Protection of the environment 21
- Tank capacity**
 AdBlue® 373
 Fuel 372
 Reserve (fuel) 372

Technical data

Axle load (trailer operation)	380
Fastening point (trailer hitch)	378
Information	364
Mounting dimensions (trailer hitch)	378
Notes (trailer hitch)	378
Overhang dimension (trailer hitch)	378
Tongue weight	379
Towing weight (towing a trailer)	379
Tyre pressure monitoring system	349
Vehicle identification plate	366
Telephone	260, 277
Activating functions during a call	282
Authorising a mobile phone (Remote Parking Assist)	236
Calls with several participants	282
Connecting a mobile phone (Pass- key)	279
Connecting a mobile phone (Secure Simple Pairing)	279
Disconnecting a mobile phone	280
Incoming call during an existing call	283
Information	279
Locking the vehicle (mobile phone)	72
Menu (on-board computer)	260

Notes	278
Reception and transmission volume	280
Starting the vehicle (mobile phone)	161
Switching mobile phones	280
Telephone menu overview	277
Telephone operation	282
Unlocking the vehicle (mobile phone)	72
Wireless charging (mobile phone)	125
Telephone number	
Dialling (on-board computer)	260
Telephone operation	
see Calls	
Temperature	147
Text messages	
see Messages	
Through-loading feature	
see Seat	
Tie-down eyes	113
Time	
Manual time setting	274
Setting summer time	273
Setting the time and date automati- cally	273

Setting the time zone	273
Setting the time/date format	274
TIREFIT kit	326
Declaration of Conformity	25
Storage location	326
Using	326
Tone settings	304
Adjusting the balance/fader	304
Adjusting treble, mid and bass	304
Calling up the sound menu	304
Information	304
Tongue weight	379
Tool	
see Vehicle tool kit	
Top Tether	51
Total distance recorder	257
Displaying	257
Touch Control	
On-board computer	253
Operating	265
Setting the sensitivity	266
Touchpad	
Operating	267

- Reading the handwriting recognition
 - aloud 268
 - Selecting a station and track 268
 - Selecting an input language 268
 - Switching on/off 266
- Tow-away protection**
 - Function 92
 - Switching on/off 93
- Tow-starting** 340
- Towing a trailer**
 - Extending/retracting the ball neck 245
- Towing away** 336
- Towing eye**
 - Installing 340
 - Storage location 339
- Towing methods** 335
- Track**
 - Selecting (audio mode) 297
- Traffic announcements**
 - Activating/deactivating 304
- Trailer hitch**
 - Axle load 380
 - Bicycle rack 248
 - Extending/retracting the ball neck 245
 - Fastening point 378
 - General notes 378
 - Mounting dimensions 378
 - Notes 244
 - Overhang dimension 378
 - Power socket 246
 - Tongue weight 379
- Trailer operation**
 - Active Blind Spot Assist 239
 - Bicycle rack 248
 - Coupling up/uncoupling a trailer 246
 - Notes 244
 - Power socket 246
- Trailer stabilisation**
 - Function/notes 195
- Trailer tow hitch**
 - Care 317
 - Towing weight 379
- Transmission position display** 172
- Transporting**
 - Vehicle 338
- Trim element (Care)** 319
- Trip**
 - Menu (on-board computer) 257
- Trip computer**
 - Displaying 257
 - Resetting 258
- Trip distance** 257
 - Displaying 257
 - Resetting 258
- Trip meter**
 - see Trip distance
- Turn signal indicator**
 - see Turn signal light
- Turn signal light** 129
 - Activating/deactivating 129
 - Changing bulbs (front) 138
 - Changing bulbs (rear) 139
- Two-way radios**
 - Frequencies 365
 - Notes on installation 364
 - Transmission output (maximum) 365
- Tyre inflation compressor**
 - see TIREFIT kit

- Tyre pressure**
 - Checking (tyre pressure monitoring system) 348
 - Notes 345
 - Restarting the tyre pressure loss warning system 352
 - Restarting the tyre pressure monitoring system 348
 - TIREFIT kit 326
 - Tyre pressure loss warning system (function) 351
 - Tyre pressure monitoring system (function) 347
 - Tyre pressure table 346
 - Tyre pressure loss warning system**
 - Function 351
 - Restarting 352
 - Tyre pressure monitor**
 - Checking the tyre pressures 348
 - Checking the tyre temperature 348
 - Function 347
 - Tyre pressure monitoring system**
 - Restarting 348
 - Technical data 349
 - Tyre pressure table** 346
 - Tyre temperature**
 - Checking (tyre pressure monitoring system) 348
 - Tyre pressure monitoring system (function) 347
 - Tyre tread** 344
 - Tyre-change tool kit**
 - Overview 356
 - Tyres**
 - Changing hub caps 357
 - Checking 344
 - Checking the tyre pressure (tyre pressure monitoring system) 348
 - Fitting 360
 - Flat tyre 324
 - MOExtended tyres 325
 - Noise 344
 - Notes on fitting 352
 - Removing 360
 - Replacing 352, 357
 - Restarting the tyre pressure loss warning system 352
 - Restarting the tyre pressure monitoring system 348
 - Selection 352
 - Snow chains 345
 - Storing 356
 - TIREFIT kit 326
 - Tyre pressure (Notes) 345
 - Tyre pressure loss warning system (function) 351
 - Tyre pressure monitoring system (function) 347
 - Tyre pressure table 346
 - Unusual handling characteristics 344
- U**
- Universal smartphone cradle**
 - Adjusting 281
 - Adjusting inclination adjuster 281
 - Features 281
 - Inserting a mobile phone 281
 - Mounting 281
 - Removing 281
 - Using 281
 - Unlocking setting** 68

USB devices

Connecting 297

USB port 124**V****Vehicle** 160, 162, 163

Activating/deactivating standby

mode 190

Additional door lock 71

Correct use 27

Damage detection (parking) 189

Data acquisition 28

Diagnostics connection 26

Equipment 23

Implied warranty 27

Locking (automatically) 75

Locking (digital vehicle key sticker) 72

Locking (emergency key) 75

Locking (from the inside) 72

Locking (KEYLESS-GO) 73

Locking (mobile phone) 72

Lowering 361

Parking up 189

QR code rescue card 27

Qualified specialist workshop 26

Raising 358

Registration 27

Starting (Digital Car Key sticker) 161

Starting (emergency operation

mode) 162

Starting (mobile phone) 161

Starting (Remote Online) 163

Starting (start/stop button) 160

Switching off (start/stop button) 181

Unlocking (digital vehicle key sticker) 72

Unlocking (from the inside) 72

Unlocking (KEYLESS-GO) 73

Unlocking (mobile phone) 72

Ventilating (convenience opening) 84

Vehicle data

Roof load 378

Vehicle height 376

Vehicle length 376

Vehicle width 376

Wheelbase 376

Vehicle data storage

Electronic control units 28

Service providers 29

Vehicle dimensions 376**Vehicle identification number**

see VIN

Vehicle identification plate

EU general operating permit number .. 366

Maximum gross vehicle weight 366

Paint code 366

Permissible axle load 366

VIN 366

Vehicle identification plate

see Model series

Vehicle interior

Cooling or heating (Remote Online) 162

Vehicle key

see Key

Vehicle maintenance

see ASSYST PLUS

Vehicle tool kit 326

TIREFIT kit 326





















Towing eye 339

Ventilating

Convenience opening 84

Ventilation

see Climate control

- Vents**
see Air vents
- VIN** 366
Identification plate 366
Seat 366
Windscreen 366
- Visibility**
Demisting the windows 150
Windscreen heater 152
- W**
- Warning lamp**
see Warning/indicator lamps
- Warning system**
see ATA (anti-theft alarm system)
- Warning triangle**
Removing 323
Setting up 323
- Warning/indicator lamp**
 ABS warning lamp 442
 Brake system warning lamp
(red) 441
 Brake system warning lamp
(yellow) 440
 Coolant warning lamp 452
 Distance warning warning lamp .. 448
 Electrical fault warning lamp 451
 Engine diagnosis warning lamp 451
 ESP® OFF warning lamp 444
 ESP® warning lamp flashes 443
 ESP® warning lamp lights up 443
 Fuel reserve warning lamp 451
 Power steering system warning
lamp 450
 Red indicator lamp, electric
parking brake applied 445
 Restraint system warning lamp ... 446
 Seat belt warning lamp flashes ... 447
 Seat belt warning lamp lights
up 446
 Suspension warning lamp 447
 Trailer hitch warning lamp 449
 Tyre pressure monitoring sys-
tem warning lamp flashes 455
 Tyre pressure monitoring sys-
tem warning lamp lights up 454
 Yellow electric parking brake
indicator lamp is malfunctioning 445
- Warning/indicator lamps** 10, 438
Instrument display (overview) 10
Overview 438
PASSENGER AIR BAG 42
- Warranty** 27
- Washer fluid**
see Windscreen washer fluid
- Washing by hand (care)** 315
- Wheel change**
Fitting a new wheel 360
Lowering the vehicle 361
Preparation 357
Raising the vehicle 358
Removing a wheel 360
Removing/fitting hub caps 357

- Wheel change**
see Emergency spare wheel
- Wheel chock**
see Chock
- Wheel rotation** 355
- Wheels**
Care 317
Changing hub caps 357
Checking 344
Checking the tyre pressure (tyre pressure monitoring system) 348
Fitting 360
Flat tyre 324
Interchanging 355
MOExtended tyres 325
Noise 344
Notes on fitting 352
Removing 360
Replacing 352, 357
Restarting the tyre pressure loss warning system 352
Restarting the tyre pressure monitoring system 348
Selection 352
Snow chains 345
Storing 356
TIREFIT kit 326
Tyre pressure (Notes) 345
Tyre pressure loss warning system (function) 351
Tyre pressure monitoring system (function) 347
Tyre pressure table 346
Unusual handling characteristics 344
- Windowbag** 38
- Windows**
see Side windows
- Windows (Care)** 317
- Windscreen** 140, 147
Demisting 147
Infrared reflective 146
Replacing the wiper blades 140
- Windscreen**
see Windscreen
- Windscreen heater** 152
- Windscreen heating**
see Windscreen heater
- Windscreen washer fluid** 376
Notes 376
- Windscreen washer system**
Topping up 313
- Windscreen wipers**
Activating/deactivating 140
Replacing the wiper blades 140
- Winter operation**
Snow chains 345
- Winter tyres**
Setting the permanent speed limit 205
- Wiper blades**
Care 317
Replacing 140
- Wireless charging**
Function/notes 124
Mobile phone 125
- Wireless vehicle components**
Declaration of conformity 24
- Workshop**
see Qualified specialist workshop

Publication details

Internet

Further information about Mercedes-Benz vehicles and about Daimler AG can be found on the following websites:

<http://www.mercedes-benz.com>

<http://www.daimler.com>

Editorial office

You are welcome to forward any queries or suggestions you may have regarding this Owner's Manual to the technical documentation team at the following address:

Daimler AG, HPC: CAC, Customer Service,
70546 Stuttgart, Germany

©Daimler AG: Not to be reprinted, translated or otherwise reproduced, in whole or in part, without written permission from Daimler AG.

Vehicle manufacturer

Daimler AG

Mercedesstrasse 137

70327 Stuttgart

Germany

As at 04.04.17



Digital – in the vehicle

Familiarise yourself with the contents of the Owner's Manual directly via the vehicle's multimedia system (menu item "Vehicle"). Start with the quick guide, discover your vehicle's highlights or broaden your knowledge with useful tips.



Vehicle document wallet

Here you can find comprehensive information about operating your vehicle and about services and warranties in printed form.



Digital – on the Internet

You can find the Owner's Manual on the Mercedes-Benz homepage.



Digital – as an App

The Mercedes-Benz Guides App is available free-of-charge in familiar App stores.



2135846507Z102

Order no. P213 0706 02 Part no. 213 584 65 07 Z102
Edition ÄJ2017-2a



Apple® iOS



Android™